

HOYEA

Industrial Hydraulics

HOYEA

Specialist In Electrohydraulics



NINGBO HOYEA MACHINERY MANUFACTURE CO., LTD.

ADD: Lixie village, Hengxi town, Yinzhou district, Ningbo, China

TEL: 0086-574-88068517

FAX: 0086-574-83086082

P.C: 315131

Http:www.hoyea.com

E-mail:sales@hoyea.com

The 1st edition in August 2023

The technical information contained in the file is subject to change without notice.

All rights reserved, pirates must investigate.

NINGBO HOYEA MACHINERY MANUFACTURE CO., LTD.

Brief Introduction

Hoyea, established in 1993, is an innovative modern enterprise, which is worthy of its name “fluid power transmission and control expert” and devotes itself to the development of Electro-hydraulic control technology.

With strong technology basis and the advantage of hydromechatronics, Hoyea develops innovative ability, and at present has large quantities of independent technology, which fill the domestic blank market a lot. Multiple advanced patents, such as “differential pressure proportional pressure flow composite valve”, and “bidirectional different pressing feedback type of proportional pilot-operated slide valve” shape a high quality technical supporting system of HOYEA. The company won the title of “National High Technological Enterprise”, “Zhejiang Patent Demonstrating Firm”, “Zhejiang Excellent Technology Innovation Enterprise”. Various kinds of products win the 2nd and 3rd place of “Science and Technology Progress Prize of Zhejiang Province” and “Outstanding New Products Prize” awarded by the national industrial organization. Among them, the proportional electro-hydraulic relief and flow control valve is classified as the national key new product, national-level Torch program project, whereas the proportional hydraulic component of new electro-hydraulic valve and the other two products has won the innovative fund project of National Science and Technology Department for technology-based small and medium-size enterprises, moreover, the proportional hydraulic component of new electro-hydraulic valve has also win the “National Major Achievements Transformation Projects” issued by the National Industrial Information Department.

The company has passed through ISO9001 quality system authentication, CE certificate, explosion-proof safety certificate and typical certificate of mineral products safety. The company has advanced processing equipment and hardware facility. The products cover the whole fields of hydraulic components, and have already been widely applied in each field. There are routine hydraulic pressure valves, proportional valves, cartridge valves, restrictive valves, explosion isolation valves and proportional solenoid, internal gear pump and valve terminal.

Therefore, Hoyea can offer its customers with comprehensive and advanced electro-hydraulic solutions, high cost-effective products, help them face the high market competition, initiate its competitive ability, and create more value for the customers.

Certificates

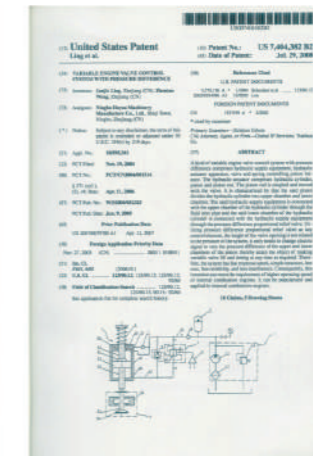

Product Introduction

Proportional valve series

1	Proportional directional valve (BFW /BFWN)	A.1.1–A.1.8
2	Proportional directional valve (BFE 2X)	A.2.1–A.2.8
3	Proportional electro-hydraulic directional valve (BFWH)	A.3.1–A.3.5
4	Proportional directly operated relief valve (BYZ)	A.4.1–A.4.3
5	Proportional pilot-operated relief valve (BY)	A.5.1–A.5.3
6	Proportional pilot-operated pressure reducing valve (BYJ)	A.6.1–A.6.3
7	Proportional electro-hydraulic control P–Q valve (BYLZ)	A.7.1–A.7.4
8	Thread type 3-way proportional reducing valve	A.8.1–A.7.3
9	2-position 2-way/3-way pressure compensated proportional flow control valve	A.9.1–A.9.3

Pressure control valves series

1	Relief valve	B.1.1–B.1.4
2	Sequence valve	B.2.1–B.2.3
3	Unloading relief valve	B.3.1–B.3.5
4	Direct-operated-reducing valve	B.4.1–B.4.2
5	Pressure reducing valve	B.5.1–B.5.3
6	Modular relief valve	B.6.1–B.6.3
7	Modular reducing valve	B.7.1–B.7.3
8	Modular counter-balance valve	B.8.1–B.8.3
9	Piston-type Pressure Switch	B.9.1–B.9.2

Flow control valve series

1	Needle valve	C.1.1–C.1.2
2	Check restrictive valve	C.2.1–C.2.2
3	Restrictive check valve	C.3.1–C.3.2
4	Modular restrictive valve	C.4.1–C.4.4
5	Modular flow control valve	C.5.1–C.5.4
6	Modular restrictive check valve	C.6.1–C.6.2
7	Flow control valve	C.7.1–C.7.2

Product Catalogue

Directional control valves series

1	In-Line check valve	D.1.1–D.1.2
2	Orthogonal check valve	D.2.1–D.2.2
3	Hydraulic-operated check valve	D.3.1–D.3.2
4	Prefill valve	D.4.1–D.4.2
5	Electrical operated directional control valve	D.5.1–D.5.10
6	Electro-hydraulic directional control valve	D.6.1–D.6.17
7	Manual operated directional control valve	D.7.1–D.7.13
8	Hydraulic-operated directional control valve	D.8.1–D.8.3
9	Water-proof electrical operated directional control valve	D.9.1–D.9.6
10	Solenoid valve with hand control	D.10.1–D.10.3
11	DN04 Solenoid valve	D.11.1–D.11.4

2-way cartridge valve series

1	Brief	E.1.1
2	2-way cartridge valve (direction function)	E.2.1–E.2.2
3	Coverplate (direction function)	E.3.1–E.3.3
4	2-way cartridge valve (pressure function)	E.4.1–E.4.2
5	Coverplate (pressure function)	E.5.1–E.5.3

Modular valves series

1	DN04 Modular pilot check valve	F.1.1–F.1.2
2	Modular relief valve	F.2.1–F.2.3
3	Modular pressure-reducing valve	F.3.1–F.3.3
4	Modular flow control valve	F.4.1–F.4.3
5	Modular check valve	F.5.1–F.5.3
6	Modular pilot-operated check valve	F.6.1–F.6.3
7	2-position 2-way subplate/modular leak-free direct-operated solenoid valve	F.7.1–F.7.9
8	Modular pressure-compensated valve	F.8.1–F.8.3

Product Introduction



Manifolds

- 1 Standard manifolds D03P G.1.1–G.1.2
- 2 Standard manifolds D03S G.2.1–G.2.2
- 3 Standard manifolds D05P G.3.1–G.3.2
- 4 Standard manifolds D05S G.4.1–G.4.2
- 5 Standard manifolds D07P G.5.1–G.5.2
- 6 Standard manifolds D07S G.6.1–G.6.2
- 7 Standard manifolds D08P G.7.1–G.7.2
- 8 Standard manifolds D08S G.8.1–G.8.2
- 9 Standard subplate D03SP G.9.1–G.9.2
- 10 Standard subplate D03SPRV G.10.1–G.10.2
- 11 Standard subplate D05SP G.11.1–G.11.2
- 12 Standard subplate D05SPRV G.12.1–G.12.2
- 13 Standard subplate D07SP G.13.1–G.13.2
- 14 Standard subplate D07SPRV G.14.1–G.14.2
- 15 Standard subplate D08SP G.15.1–G.15.2
- 16 Standard subplate D08SPRV G.16.1–G.16.2

Proportional Valve Series



WWW.GIDRODOM.COM

Proportional Directional Valve (BFW/BFWN)



The built-in 4/2- and 4/3-way directly operated Proportional solenoid valves
 Direct operated spool without electrical position feedback
 Type BFW and BFWN
 Nominal sizes 6 and 10
 Series 2X
 Maximum operating pressure 315bar
 Maximum flow 42L/min (DN6)
 Maximum flow 75L/min (DN10)

Technical data (Please consult with us when the application needs higher requirement than the parameter shown below)

Model	BFW	BFWN
Installation position	optional, preferably horizontal	
Storage temperature range (°C)	-20~80	
Ambient temperature range (°C)	-20~70	-20~50

Hydraulic

Operating pressure (bar)	Ports A, B, P	315
	Port T	210
Nominal flow When q_{vnom} at $\Delta p=10$ bar (L/min)	DN6	7, 15 and 26
	DN10	30, 60
Flow (Max. Permissible) (L/min)	DN6	80 (with double flow 80) 80
	DN10	140 (with double flow 140) 140
Pressure fluid	Mineral oil (HL, HLP) to DIN 51 524; For other fluid please consult with us.	
Fluid temp. Range (°C)	-20~80(+40~+50 is preference)	
Viscosity range (mm ² /s)	20~380(30~46 is preference)	
Hysteresis (%)	≤5	
Reversal error (%)	≤1	
Response sensitivity (%)	≤0.5	
Cleanliness	Maximum permissible degree of pressure fluid contamination to NAS 1638 to class 9 Recommended filter $\beta_{10} \geq 75$.	

Electrical

Model	BFW ¹⁾	BFWN
Voltage type	Direct voltage	
BFWN Command signal	Voltage input "A1" (V)	± 10
	Current input "F1" (mA)	4~20
Max. current per solenoid (A)	2.5	2.5
Solenoid coil Resistance (Ω)	Cold value at 20 °C	6DN2
	Max. warm value	10DN2
Duty cycle (%)	100	
Max. Coil temperature ²⁾ (°C)	up to 150	
Electrical connection	socket as per DIN EN 175 301-803 and ISO 4400 with component plug to DIN EN 175301-803 and ISO 4400	socket as per DIN EN 43 563-AM6-3 with component plug to DIN 43 563-BF6-3/Pg11
Insulation of valve to DIN 40 050	IP 65	

Proportional Directional Valve (BFW/BFWN)

Control electronics

BFW (type)	Analogue amplifier in Eurocard format ³⁾	Details refer to proportional amplifier	
	Digital amplifier in Eurocard format ³⁾	Details refer to proportional amplifier	
BFWN (type)	Analogue command value module	Integrated into the valves	
Supply voltage	Nominal voltage	VDC	24
	BFWN Lower limiting value	V	21/22
	BFW ¹⁾ Upper limiting value	V	35
Amplifier current consumption	/ max	A	1.8
	Max. impulse current	A	3

1) With HOYEA control amplifier. 2) Due to the occurring surface temperature of the solenoid coils, the European Standards DIN EN 563 and DIN EN 982. 3) separate order.

Model description

BFW - * - * - * - * - 2X - G24 - * - * - * - *

Directional proportional valve

No code Without integrated electronics
 N With integrated electronics

02 DN 6
 03 DN 10

Spool symbols

Further details in clear text

Omit Nitrile rubber sealing
 V NBR seals suitable for mineral oil (HL, HLP) to DIN 51 524

No code BFW(type)
 BFWN(type)
 A1 Command value input ± 10V
 F1 Command value input 4~20mA

Electrical connection For BFW (type)
²⁾K4 with plug component DIN EN 175301-803 See page A.1.3
 BFWN (type)
²⁾K31 with plug component DIN 43 650-AM2 See page A.1.4

Special protection
 No code Without special protection
¹⁾J Seawater-resistant (only for DN6)

24V 24 VDC

2X Component series 20 to 29 (20 to 29 unchanged installation and connection dimensions)

Nominal flow at valve pressure differential p = 10 bar

DN	Flow (L/min)
DN 6	07 7 L/min
	15 15 L/min
	30 26 L/min
DN 10	
	30 30 L/min
	60 60 L/min

With spool symbols: 3C2(1) and 3C40(1)
 P → A: q_{vmax} B → T: $q_{vmax}/2$
 P → B: $q_{vmax}/2$ A → T: q_{vmax}

Note:
 With spools 3C40 and 2B40B, in the neutral position, there is a connection from A to T and B to T with approx. 3% of the relevant nominal cross section.

1. Other types of electrical protection on request 2. Only for DN6: for version "3C40" sea water resistant only state "K 31"!

Proportional Directional Valve (BFW/BFWN)

Model description

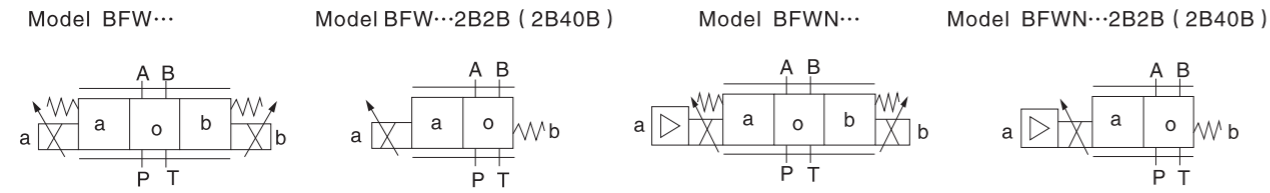

Structure and function description, section

The 4/2-way and 4/3-way proportional directional valves are designed as direct operated components for subplate mounting. They are actuated by means of proportional solenoid with central removable coil. The solenoid are controlled either by external control electronics (type BFW) or integrated control electronics (type BFWN).

Design:

The valves basically consist of:

- Body (1) with mounting surface
- Control spool (2) with compression springs (3 and 4)
- Solenoids (5 and 6) with central coil
- Optional integrated electronics (7)

Function:

- When solenoids (5 and 6) do not work, the control spool (2) is held in the central position by compression springs (3 and 4)
- Direct actuation of the control spool (2) by energising a proportional solenoid E.g. When the solenoid "b" power is on (6)
 - The control spool (2) is moved to the left in proportion to the electrical input signal
 - connection from P to A and B to T via orifice-like crosssections with progressive flow characteristics
- When the solenoid power is off (6)
 - The control spool (2) is returned to the central position by compression spring (3)

Model BFW-02...2x/...

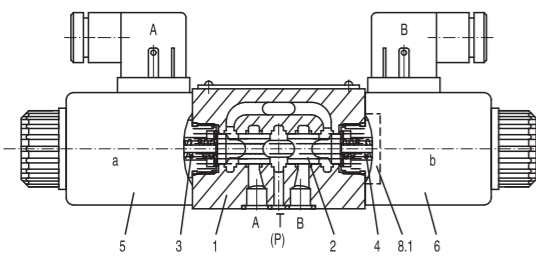

In theory, the function of this valve is the same to the valve with 3 positions. However, the valves with 2 positions are only fitted with solenoid "a". For DN6 valve, there is a plug (8.1) fixed in the second solenoid, but for DN10, it is a cover (8.2) instead.

Model BFWN-03...2x/...

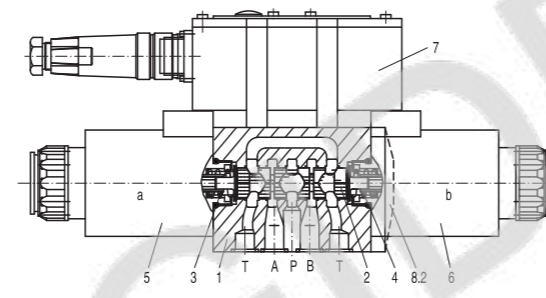

Note for type BFW-02...2X/...: Draining of tank line is to be avoided. With the appropriate installation conditions, a back pressure valve is to be installed (back pressure approx. 2 bar).

Electrical connection, plug-in connectors

BFW type (Without integrated electronics not for version "J"=sea water-resistant)

Connection on component plug

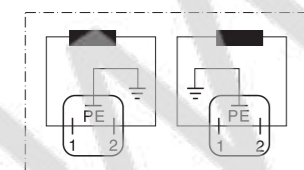

Connection on plug-in connector

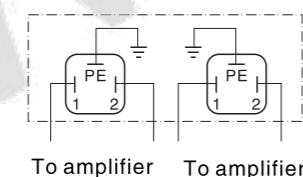

Plug-in connector: CECC 75 301-803-A002FA-H3D08-G/DIN EN 175 301-803 and ISO 4400

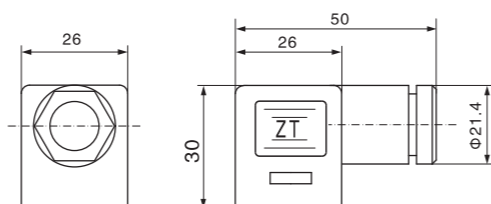

Proportional Directional Valve (BFW/BFWN)

Electrical connection, plug-in connectors

For type BFWN (with integrated electronics (OBE) and for version "J" = sea water-resistant) Plug-in connector see the block circuit diagram below

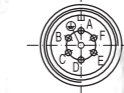
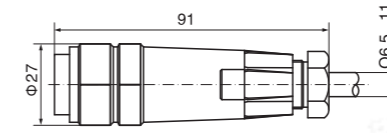

Plug-in connector: DIN 43 563-BF6-3/Pg11

Integrated electronics for type BFWN

Pin allocation of the component plug

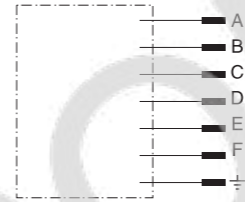

	Contact	Signal
Supply voltage	A	24VDC(19~35VDC)
	B	GND
	C	n.c. ⁽¹⁾
Differential amplifier input	D	Com. value (± 10V/4~20mA) reference potential
	E	
	F	n.c. ⁽¹⁾

Com. value: Positive command value (0 to 10 V or 12 to 20 mA) at D and reference potential to E causes flow from P to A and B to T. Negative command value (0 to 10 V or 12 to 4 mA) at D and reference potential to E causes flow from P to B and A to T.

For valves with a solenoid on side "a" (spool variants 2B2B and 2B40B) a positive command value at D and reference potential to E (NS 6: 4 to 20 mA and NS 10: 12 to 20 mA) causes flow from P to B and A to T.

Recommendation:

- up to 25 m cable length type LiYCY 5 x 0.75 mm²
- up to 50 m cable length type LiYCY 5 x 1.0 mm²
- External diameter 6.5 to 11 mm
- Connect screen to PE only on the supply side

Block circuit diagram / connection allocation

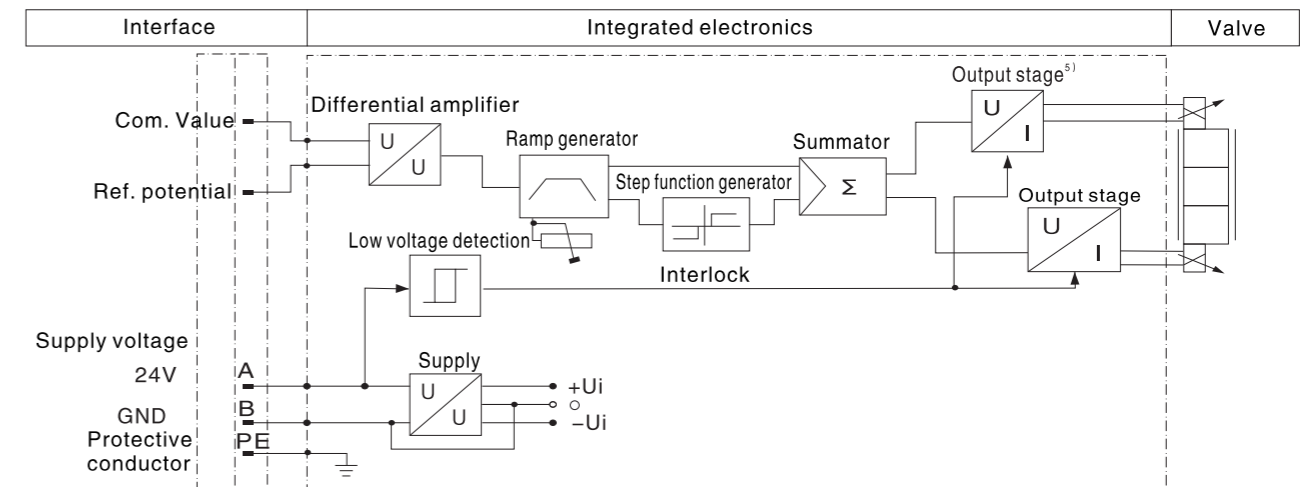

- 1) Contacts C and F must not be connected!
- 2) PE is connected to the cooling body and the valve housing
- 3) Protective conductor screwed to the valve housing and cover
- 4) Ramp can be externally adjusted from 0 to 2.5 s; the same applies for T_{up} and T_{down}
- 5) Output stages current regulated
- 6) Low voltage detection is not carried out for component type BFWN-03-2X

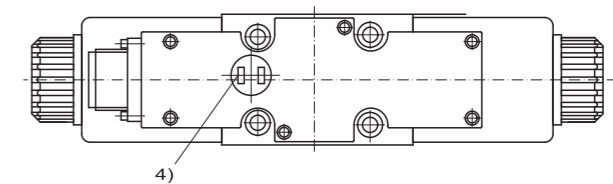

Proportional Directional Valve (BFW/BFWN)

Characteristic curves

DN6
Transient functions with stepped form of electrical input signa

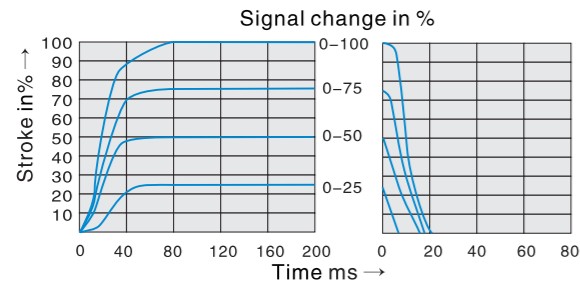

Performance limit, nominal flow 7 L/min

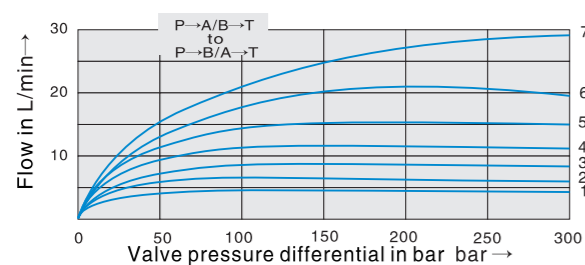

Performance limit, nominal flow 15 L/min

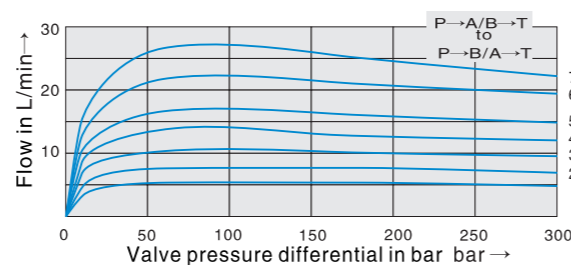

Performance limit, nominal flow 30 L/min

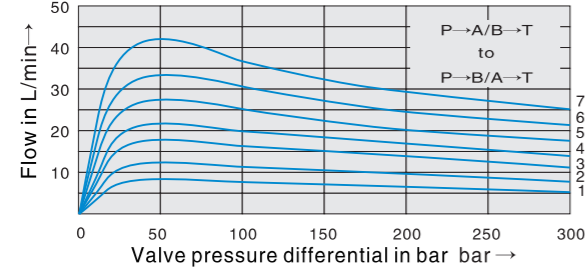

- 1 Com. Value=40%
- 2 Com. Value=50%
- 3 Com. Value=60%
- 4 Com. Value=70%
- 5 Com. Value=80%
- 6 Com. Value=90%
- 7 Com. Value=100%

If the performance limits are exceeded, then the movement of spool will be unstable.

DN10

Transient functions with stepped form of electrical input signa

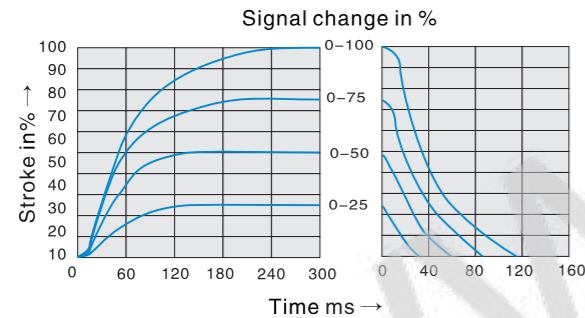

Performance limit, nominal flow 30 L/min

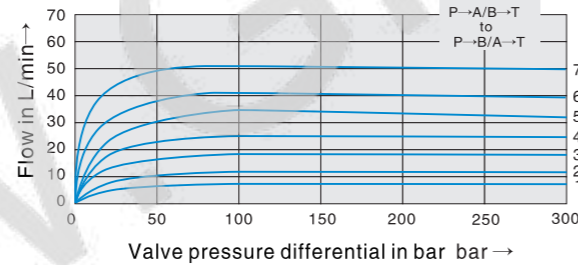

Performance limit, nominal flow 60 L/min

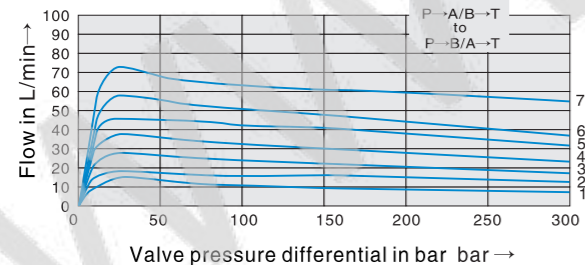

- 1 Com. Value=40%
- 2 Com. Value=50%
- 3 Com. Value=60%
- 4 Com. Value=70%
- 5 Com. Value=80%
- 6 Com. Value=90%
- 7 Com. Value=100%

If the performance limits are exceeded, then the movement of spool will be unstable.

Proportional Directional Valve (BFW/BFWN)

Characteristic curves (measured with HLP46, Qoil = 40 ± 5°C) DN6

7 l/min nominal flow at differential pressure 10 bar

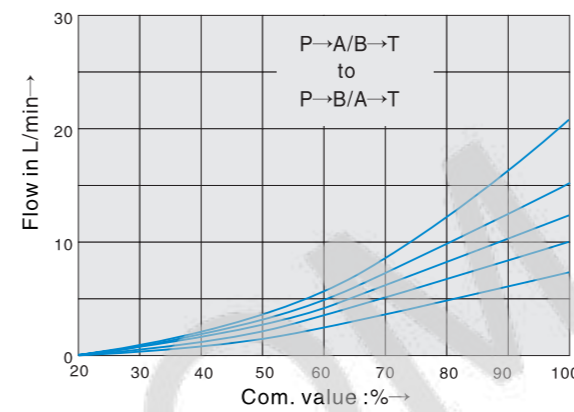

15 l/min nominal flow at differential pressure 10 bar

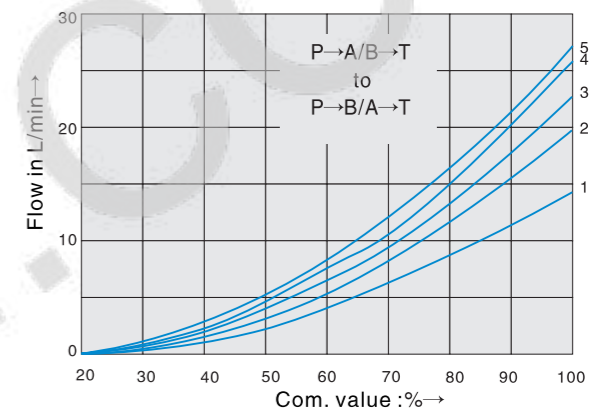

30 l/min nominal flow at differential pressure 10 bar

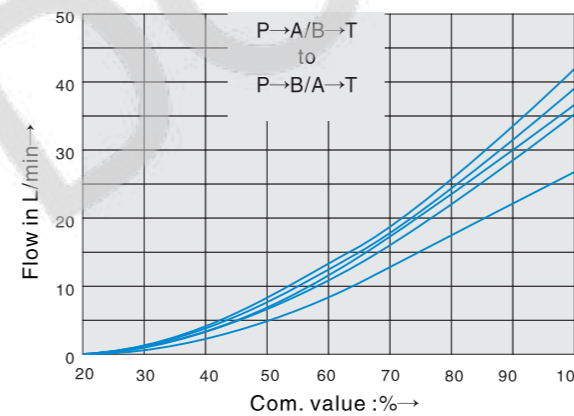

- 1 $\Delta p=10$ bar Constant
- 2 $\Delta p=20$ bar Constant
- 3 $\Delta p=30$ bar Constant
- 4 $\Delta p=50$ bar Constant
- 5 $\Delta p=100$ bar Constant

Δp = Valve pressure differential (inlet pressure P_p minus load pressure P_L and minus return pressure P_T)

Characteristic curves (measured with HLP46, Qoil = 40 ± 5°C) DN10

30 l/min nominal flow at differential pressure 10 bar

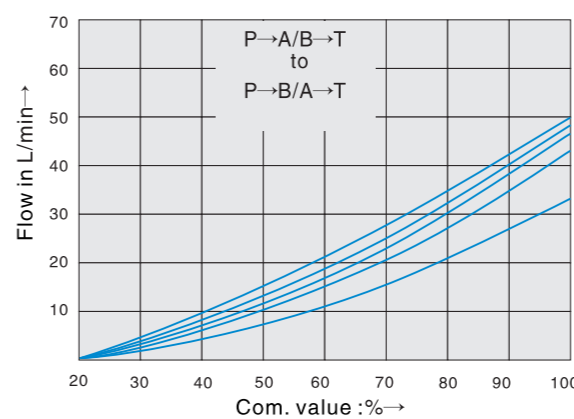

60 l/min nominal flow at differential pressure 10 bar

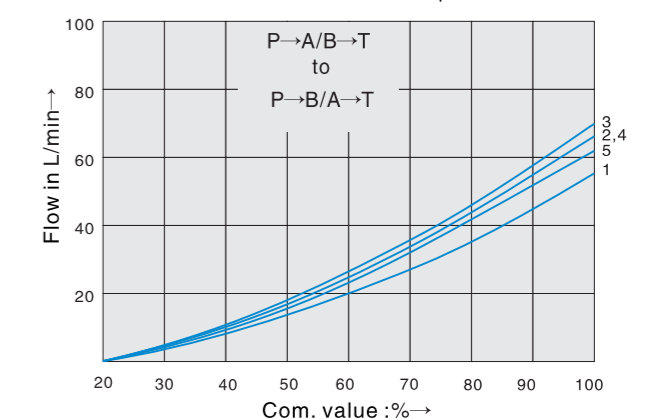

- 1 $\Delta p=10$ bar Constant
- 2 $\Delta p=20$ bar Constant
- 3 $\Delta p=30$ bar Constant
- 4 $\Delta p=50$ bar Constant
- 5 $\Delta p=100$ bar Constant

Δp = Valve pressure differential (inlet pressure P_p minus load pressure P_L and minus return pressure P_T)

Proportional Directional Valve (BFW/BFWN)

Unit dimensions

BFW-02 type

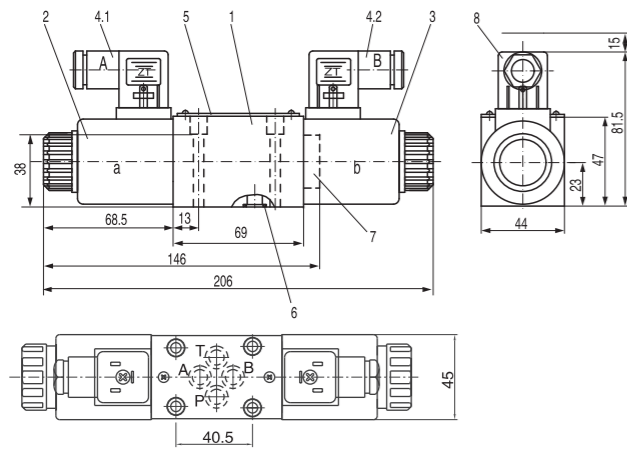

BFWN-02.../...K31...V type

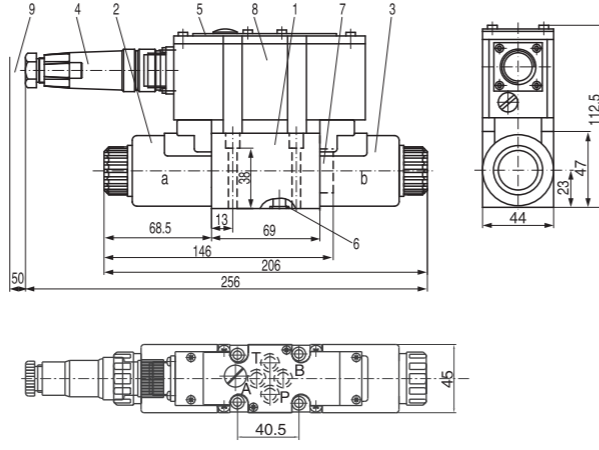

- 1 Valve body
- 2 Proportional solenoid "a"
- 3 Proportional solenoid "b"
- 4.1 4.2 Plug-in connector , colour black, separate order
- 5 Nameplate
- 6 8.73 x 1.78 I seal rings for ports A, B, P and T
- 7 Plug for valves with one solenoid (2 positions spool type 2B2B or 2B40B)
- 8 Space required to remove the plug-in connector
- 9 Machined valve mounting surface, connection location to DIN 24 340A, IS04401 (and) CETOP-RP 121 H

- 1 Valve body
- 2 Proportional solenoid "a"
- 3 Proportional solenoid "b"
- 4 Plug-in connector to E DIN 43 563-BF6-3/Pg11
- 5 Nameplate
- 6 8.73 x 1.78 O Identical seal rings for ports A, B, P and T
- 7 Plug for valves with one solenoid (2 switched positions, spool type 2B2B or 2B40B)
- 8 Integrated electronics
- 9 Space required for the connection cable and to remove the plug-in connector
- 10 Machined valve mounting surface, connection location to DIN 24 340A, ISO 440 and CETOP-RP 121 H

Mounting plate: please refer to below drawing
Subplates: Valve fixing screws :4-M5x 45 DIN 912-12.9; $M_A=8.9$ Nm

Subplate size

BFW-02
BFWN-02

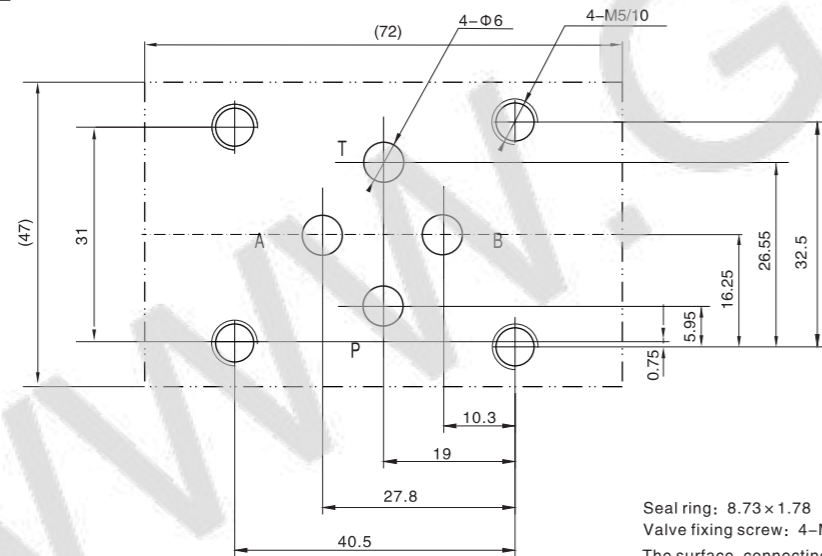

Seal ring: 8.73 x 1.78
Valve fixing screw: 4-M5 x 45-12.9(GB70-85)
The surface, connecting with the valve, should be Ra0.8 roughness, and 0.01/100mm flatness.

Proportional Directional Valve (BFW/BFWN)

Unit dimensions

BFW-03 type

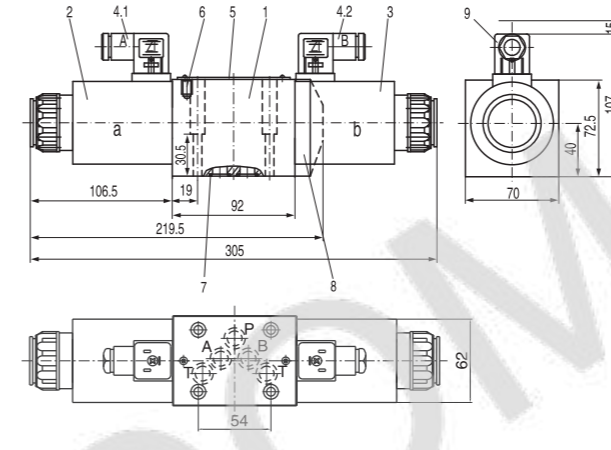

BFWN-03 type

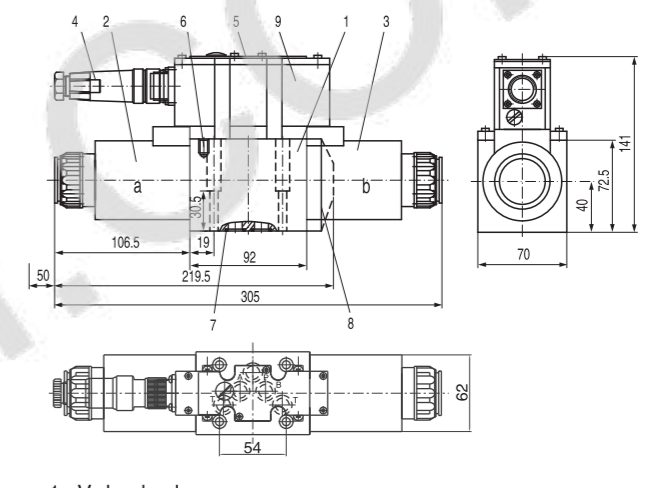

- 1 Valve body
- 2 Proportional solenoid "a"
- 3 Proportional solenoid "b"
- 4.1 4.2 Plug-in connector , colour black, separate order
- 5 Nameplate
- 6 Valve deflation screw
- 7 12 x 2 seal rings for ports A, B, P and T
- 8 Plug for valves with one solenoid (2 positions, spool type 2B2B or 2B40B)
- 9 Space required to remove the plug-in connector
- 10 Machined valve mounting surface, connection location to DIN 24 340A, IS04401 (and) CETOP-RP 121 H

- 1 Valve body
- 2 Proportional solenoid "a"
- 3 Proportional solenoid "b"
- 4 Plug-in connector, to E DIN43563-BF6-3/Pg11
- 5 Nameplate
- 6 Valve deflation screw
- 7 12 x 2 I O identical seal rings for ports A, B, P and T
- 8 Plug for valves with one solenoid (2 positions, spool type 2B2B or 2B40B)
- 9 Integrated electronics
- 10 Space required for the connection cable and to remove the plug-in connector
- 11 Machined valve mounting surface, connection location to DIN 24 340A, IS04401 (and) CETOP-RP 121 H

Mounting plate: please refer to below drawing
Subplates : Valve fixing screws: 4 M6x 40 DIN 912-12.9; $M_A=15.5$ Nm

Subplate size

BFW-03
BFWN-03

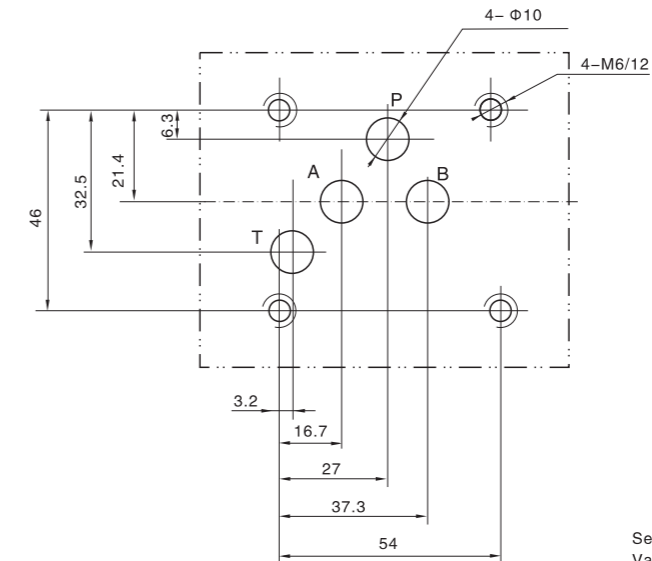

Seal ring: 8.73 x 1.78
Valve fixing screw: 4-M5 x 45-12.9(GB70-85)
The surface, connecting with the valve, should be Ra0.8 roughness, and 0.01/100mm flatness.

Proportional Directional Valve (BFWE 2X)



The 4/2- and 4/3-way directly operated proportional directional valves, Spool with electrical position feedback. Type BFWE and BFWNE

Nominal size DN6 and DN10
Component series 2X
Maximum operating pressure 315bar
Maximum flow 80L/min DN 6 (DN6)
Maximum flow 180L/min DN 10 (DN10)

Technical data (For application outside these parameters please consult with us)

Specification	BFWE	BFWNE
Installation position	optional, preferably horizontal	
Storage temperature range (°C)	-20~80	
Ambient temperature range (°C)	-20~70	-20~50

Tested under the condition of (P=100bar, Mineral oil HLP4+, 40C±5C)

Operating pressure (bar)	Ports A, B, P	315	
	Port T	100	
Nominal flow Q _{vnom} Max at p=10 bar (L/min)	6DN	8	16
	10DN	25	50
Flow (Max. Permissible) (L/min)	6DN	80	
	10DN	180	
Pressure fluid	Mineral oil (HL, HLP) to DIN 51 524; For other fluid please consult with us.		
Fluid temp. Range (°C)	-20~80(+40~+50 is preference)		
Viscosity range (mm ² /s)	20~380(30~46is preference)		
Hysteresis (%)	≤0.1		
Reversal span (%)	≤0.05		
Response sensitivity (%)	≤0.05		
Zero displacement will vary in pressure oil temperature and working temperature.	%/100 (K)	0.15	
	%/100 (bar)	0.1	
Cleanliness	Maximum permissible degree of pressure fluid contamination to NAS 1638 to class 9 Recommended filter β ₁₀ ≥75 .		

Electrical

Voltage type		Direct voltage	
BFWN Command signal	Voltage input "A1" (V)	± 10	± 10
	Current input "F1" (mA)	4~20	4~20
Max. current per solenoid (A)		2.5	2.5
Solenoid coil Resistance (Ω)	Cold value at 20 °C	6DN2.7	10DN3.7
	Max. warm value	6DN4.05	10DN5.55
Duty cycle (%)		100	
Max. Coil temperature ²⁾ (°C)		up to 150	
Electrical connection	socket as per DIN EN 175 301-803 and ISO 4400 with component plug to DIN EN 175301-803 and ISO 4400		socket as per DIN EN 43 563-AM6-3 with component plug to DIN 43 563-BF6-3/Pg11
Insulation of valve to DIN 40 050	IP 65		

Proportional Directional Valve (BFWE 2X)

Control electronics

BFW (type)	Analogue amplifier in Eurocard format ³⁾		Details refer to proportional amplifier		
	Digital amplifier in Eurocard format ³⁾		Details refer to proportional amplifier		
BFWN (type)	Analogue command value module		Integrated into the valves A1.4		
Supply voltage	BFWE ¹⁾ BFWNE	Rated voltage	VDC	24	
		Lower limiting value	V	21/22	19.4
		Upper limiting value	V	35	
Amplifier current consumption		I _{Max}	A	2	
		Max. impulse current	A	3	

1) With HOYEA control amplifier. 2) Due to the occurring surface temperature of the solenoid coils, the European Standards DIN EN 563 and DIN EN 982. 3) separate order.

Model description

BFW - * - E - * - * - * - 2X - G24 - * - * - * - *

Proportional directional valve

No code Without integrated electronics
N With integrated electronics

Spool with displacement sensor

02 DN 6
03 DN 10

Spool symbols

Further details in clear text

Omit NBR seal
V FPM seals suitable for mineral oil
Hydraulic oil
(HL, HLP) as per Din 51 524

No code BFW(type)
BFWN(type)
A1 Command value input ± 10V
F1 Command value input 4~20mA

Electrical connection
BFW (type)
²⁾K4 with plug component DIN EN 175301-803
BFWN(type)
²⁾K31 with plug component DIN 43 650-AM2

2X= 24V 24 VDC

2X Component series 20 to 29 (20 to 29 unchanged installation and connection dimensions)

Nominal flow at valve differential pressure p = 10 bar

DN	Flow (L/min)
6	8
6	16
10	32
10	25
10	50
10	75

With spool symbols: 3C2(1) and 3C40(1)
P → A: q_{vmax} B → T: q_{vmax}/2
P → B: q_{vmax}/2 A → T: q_{vmax}

Note:
With spools 3C40 and 2B40B, in the neutral position, there is a connection from A to T and B to T with approx. 3% of the relevant nominal cross section.

Proportional Directional Valve (BFWE 2X)

Model description

Directional Proportional valve without integrated electronics

Directional Proportional valve with integrated electronics

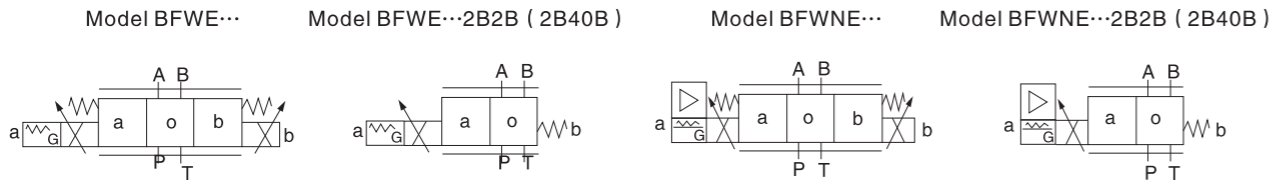

Structure and function description, section

The 4/2-way and 4/3-way proportional directional valves are designed as direct-operated components for subplate mounting. They are actuated by means of proportional solenoid with central removable coil. The solenoid are controlled either by external control electronics (type BFWE) or integrated control electronics (type BFWNE)

Design:

- The valves basically consist of:
 - Body (1) with mounting surface
 - Control spool (2) with compression springs (3 and 4)
 - Solenoids (5 and 6) with central coil
 - Optional integrated electronics (7)
 - integrated amplifier(8) available
 - mechanical zero adjust via (9)
 - BFWNW electro zero adjust via (10)

Function:

- When solenoids (5 and 6) do not work, the control spool (2) is held in the central position by compression springs (3 and 4)
- Direct actuation of the control spool (2) by energising a proportional solenoid E.g. When the solenoid "b" power is on (6)
 - The control spool (2) is moved to the left in proportion to the electrical input signal
 - connection from P to A and B to T via orifice-like crosssections with progressive flow characteristics
- When the solenoid power is off (6)
 - The control spool (2) is returned to the central position by compression spring (3)

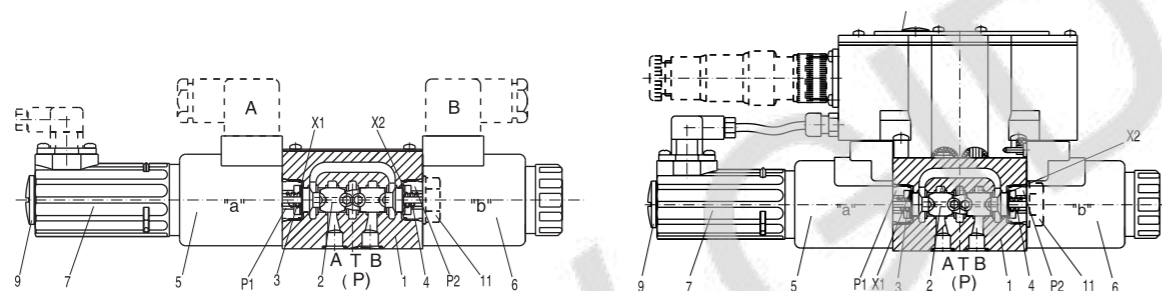

Valve with 2 spool positions:

In theory, the function of this valve is the same to the valve with 3 positions. However, the valves with 2 positions are only fitted with solenoid "a" (5). Instead of the 2nd proportional solenoid a plug (11) is fitted with a cover for DN 6 or for DN 10 (11).

Note for type BFW-02...2X/...: Draining of tank line is to be avoided. With the appropriate installation conditions, a back pressure valve is to be installed (back pressure approx. 2 bar).

Proportional Directional Valve (BFWE 2X)

Electrical connection, plug-in connectors

BFWE type (Without integrated electronics not for version "J"=sea water resistant)

Plug-in connector: CECC 75 301-803-A002FA-H3D08-G/DIN EN 175 301-803 (and) ISO 4400

Connection on component plug

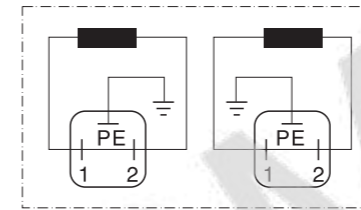

Connection on plug-in connector

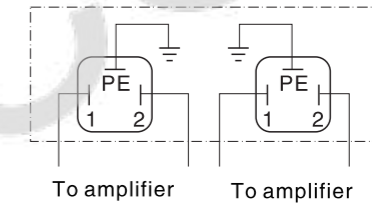

Outlook size of plug-in connector

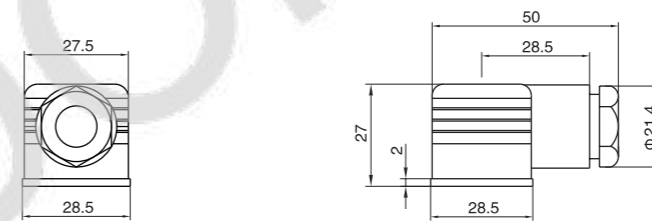

Inductive position transducer

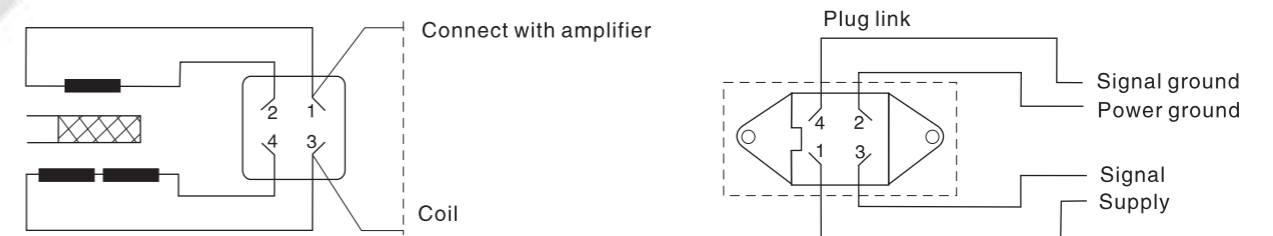

Mating connector 4-role connector cable
Suggestion: the length of the wire is expected to be 50 meters, type LiYCY 4*0.25mm²
Connect shield to PE only on the supply side.

Outlook size of plug-in connector

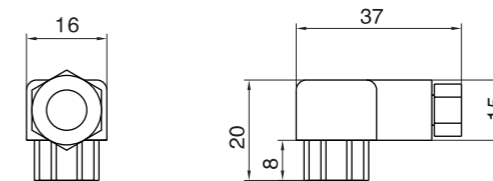

Plug-in connector: the plug-in connector should be met with the standard: DIN EN 175 201-804

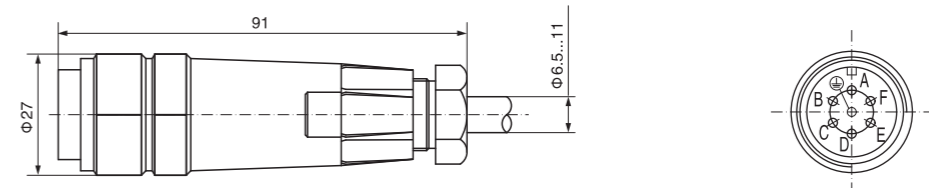

Proportional Directional Valve (BFWE 2X)

Pin allocation of the component plug

	Plug-in connector	A1 Connector type A1	Connector type F1
Supply	A	24VDC(u(t)=19.4~35V); $I_{max}=2A$	
Voltage	B	0V	
Reference potential(actual value)	C	Link to F; $R_o > 50K\Omega$	Link to F; $R_o < 10\Omega$
Differential amplifier input	D	Com. Value $\pm 10V$; $R_o > 50K\Omega$	
	E	Reference potential set value	
Measuring the output (actual value)	F	Actual value $\pm 10V$, (Current limiter 5mA)	
	PE	Link to the valve body and low-temperature subjects	

Com. value : Positive command value (0 to 10 V or 12 to 20 mA) at D and reference potential to E causes flow from P to A and B to T. Negative command value (0 to -10 V or 12 to 4 mA) at D and reference potential to E causes flow from P to B and A to T. For valves with a solenoid on side "a" (spool variants EA and WA) a positive command value at D and reference potential to E (NS 6: 4 to 20 mA and NS 10: 12 to 20 mA) causes flow from P to B and A to T.

Actual value : The actual value (0~10V or 12mA) on the F.C enables the connection from port P to port A.

Connection cable : Recommendation:

- up to 25 m cable length type LiYCY 5 x 0.75 mm²
- up to 50 m cable length type LiYCY 5 x 1.0 mm² External diameter 6.5 to 11 mm
- Connect screen to PE only on the supply side

Block circuit diagram / connection allocation

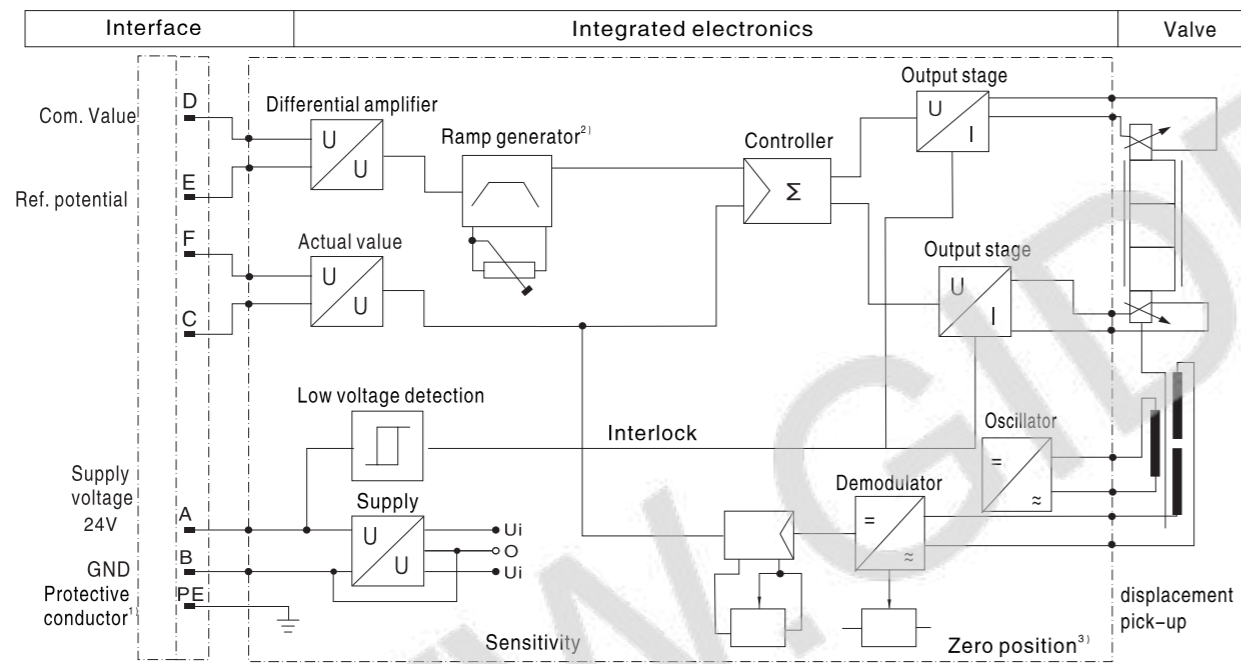

Introductions:

The electrical signal launched from controlled amplifier (e.g. actual value) must not be used for the safety protection of the switch device.

1. Contacts PE should be linked to the low-temperature subject and valve body.
2. Ramp time could be adjustable within the scope 0~02.5s outside, as well as T_{up} and T_{down} .
3. Zero point outside is adjustable.
4. output end is the current output
5. Zero point can be set from the outside

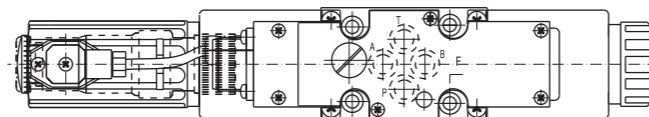

Proportional Directional Valve (BFWE 2X)

Characteristic curves (measured with HLP46, Qoil = 40 ± 5°C) DN6

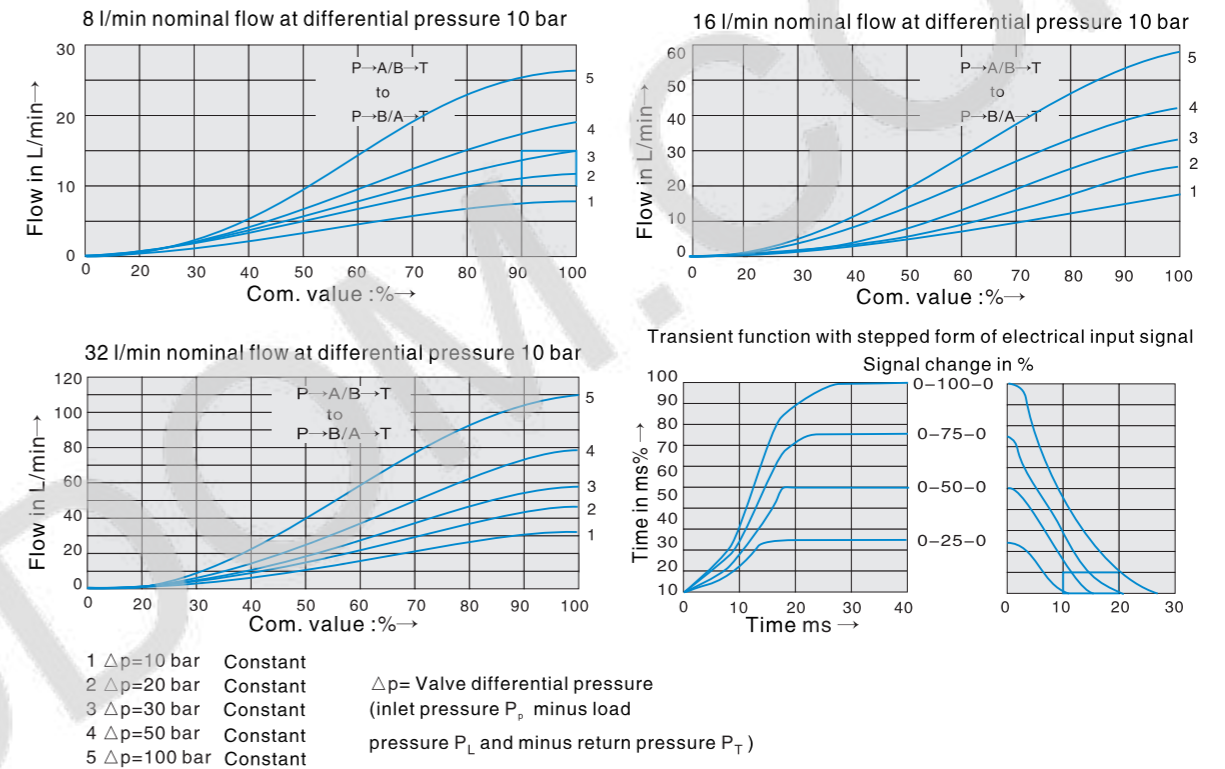

Characteristic curves (measured with HLP46, Qoil = 40 ± 5°C) DN10

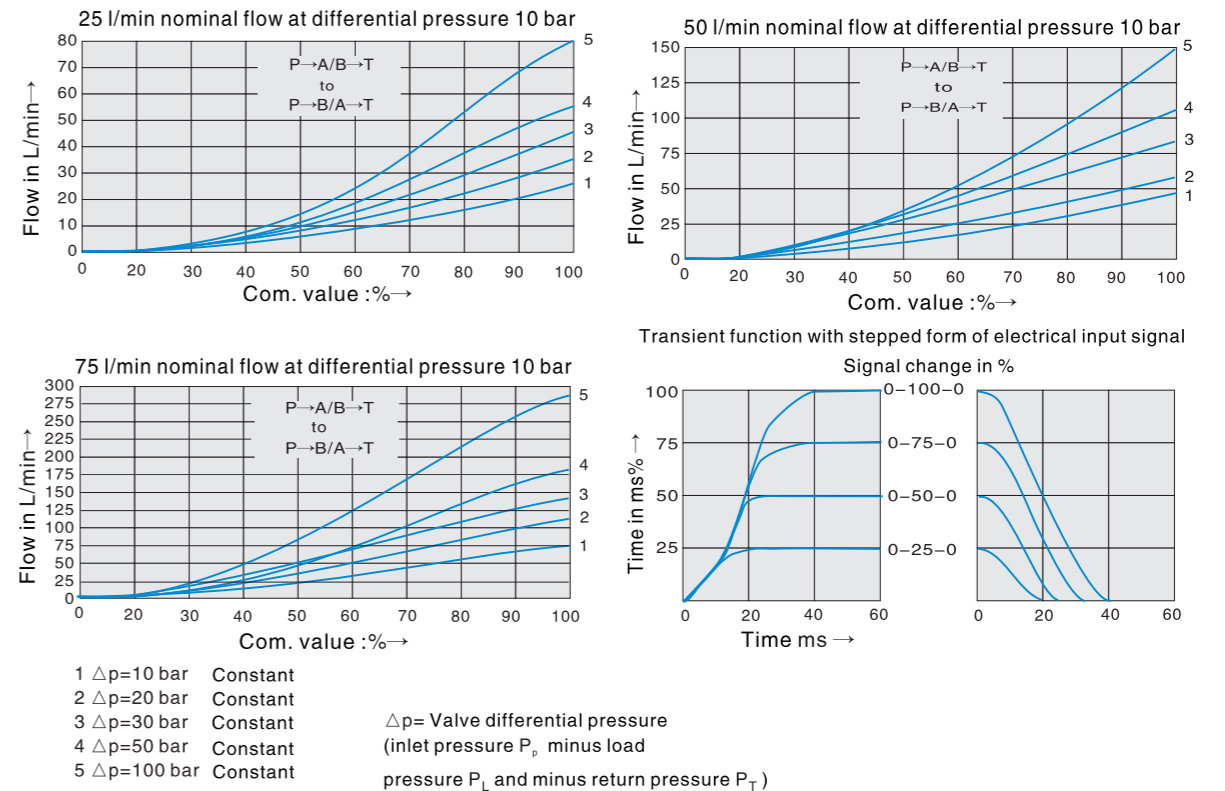

Proportional Directional Valve (BFWE 2X)

Unit dimensions

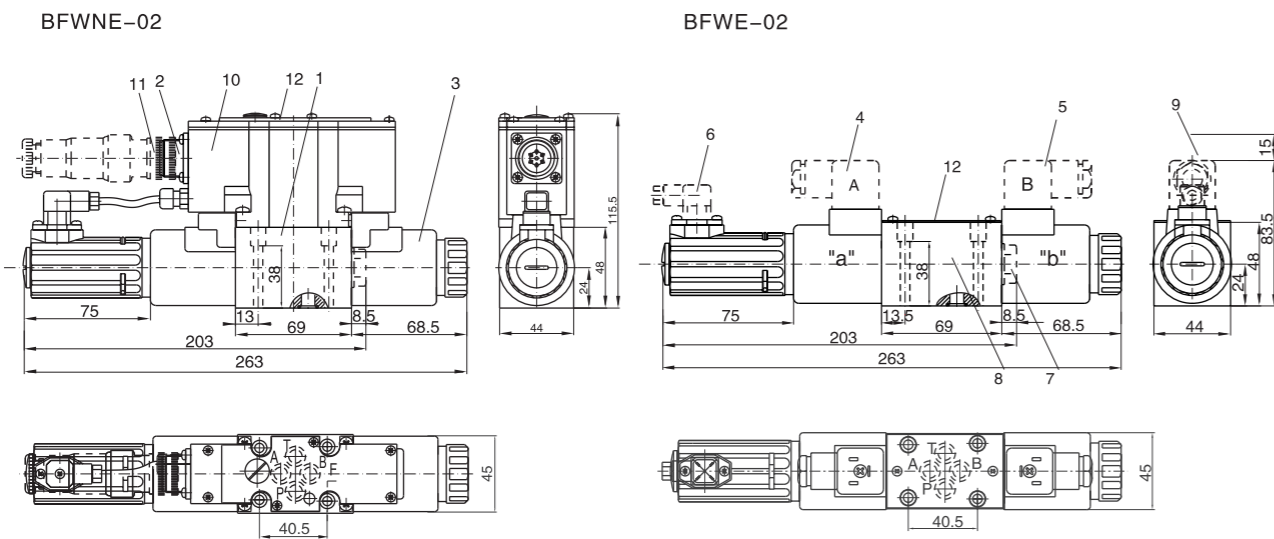

1. Valve body
2. Proportional solenoid "a" with inductive displacement pick-up
3. Proportional solenoid "b"
4. Gray plug-in connector "A" according to the standard of DIN EN 175 301-803
5. Black plug-in connector "B" according to the standard of DIN EN 175 301-803
6. Socket with inductive displacement pick-up
7. For single-solenoid-controlled valve end lever, spool type 2B2B or 2B40B
8. Identical seal ring 8.73*1.78 (used for ports A, B, P, T)
9. Space for taking off the plug-in connector
10. Built-in amplifier
11. The socket corresponds with DIN EN 175 201-804
12. Nameplate
13. Machined valve mounting surface, Connection location to DIN 24 340A, ISO4401 (and) CETOP-RP 121 H

Subplate size

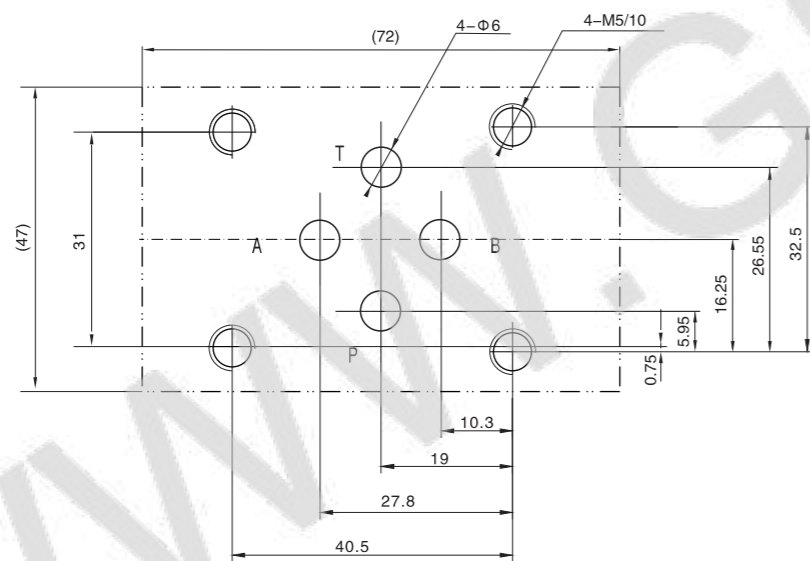

Subplates: G341/01(G1/4) G342/01(G3/8) G502/01(G1/2)
 Valve fixing screws: 4-M5x45 DIN 912-10.9; $M_s=8.9$ Nm
 The surface, connecting with the valve, should be Ra0.8 roughness, and 0.01/100mm flatness.

Proportional Directional Valve (BFWE 2X)

Unit dimensions

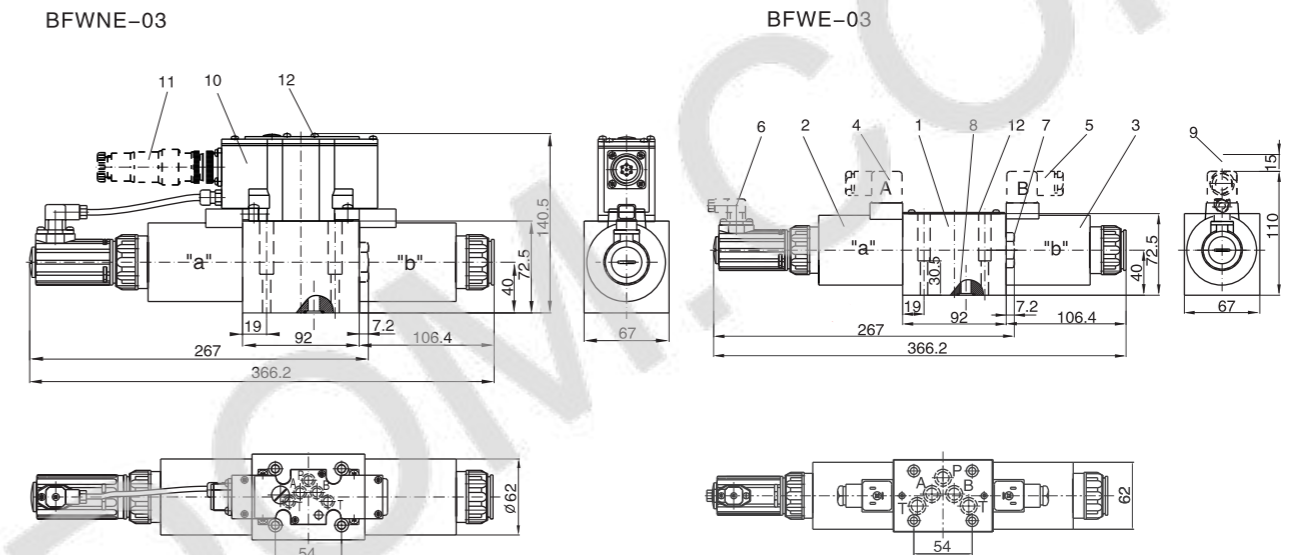

1. Valve body
2. Proportional solenoid "a" with inductive displacement pick-up
3. Proportional solenoid "b"
4. Gray plug-in connector "A" according to the standard of DIN EN 175 301-803, place another order
5. Black plug-in connector "B" according to the standard of DIN EN 175 301-803, place another order
6. Socket with inductive displacement pick-up
7. For single-solenoid-controlled valve end lever, spool type 2B2B or 2B40B
8. Identical seal ring 12*2 (used for ports A, B, P, T)
9. Space for taking off the plug-in connector
10. Built-in amplifier
11. The socket corresponds with DIN EN 175 201-804
12. Nameplate
13. Machined valve mounting surface, Connection location to DIN 24 340A, ISO4401 (and) CETOP-RP 121 H

Subplate size

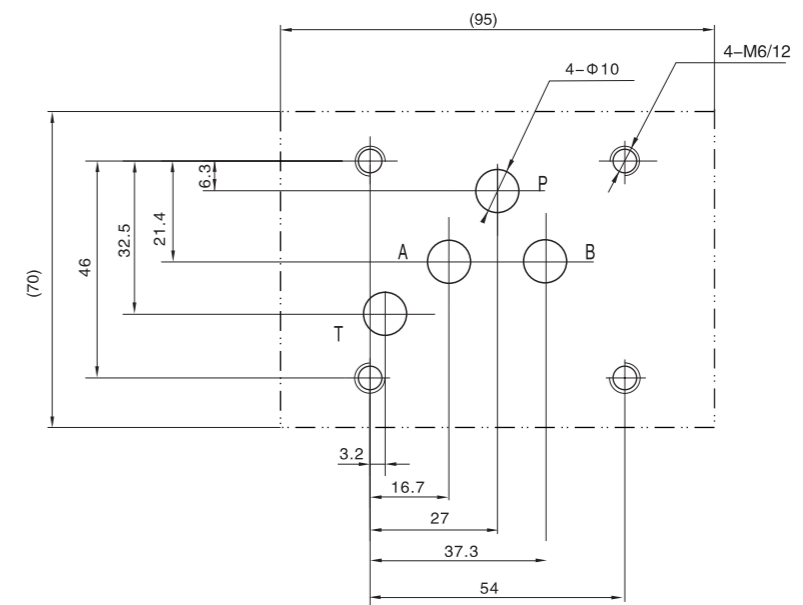

Valve fixing screws: 4-M6x40 DIN 912-10.9; $M_s=8.9$ Nm
 The surface, connecting with the valve, should be Ra0.8 roughness, and 0.01/100mm flatness.

Proportional Electro-hydraulic Directional Valve(BFWH)

Technical specification

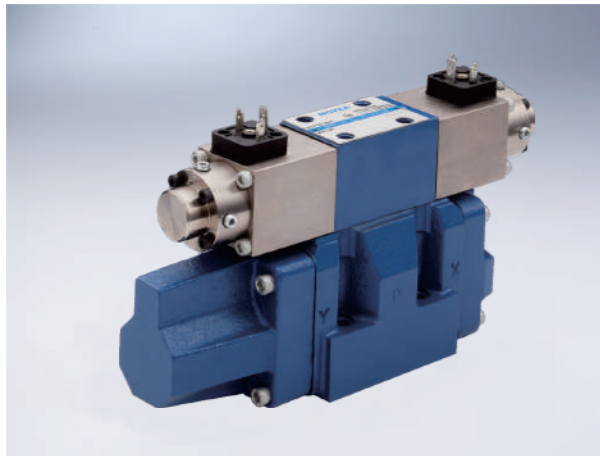

BFWH electro-hydraulic proportional directional valve is a 2-stage valve with a pilot. It is controlled by a proportional solenoid and converts the electrical signal into a fluid pressure signal to control the flow rate and directions in the hydraulic system.

Specification		03	04	06
Maximum pressure (MPa)		31.5		
Return pressure (MPa)	T(For extl disch)	< 25		
	T(For intl disch)	< 3		
	Port Y	< 3		
Maximum flow (l/min)	85	150	325	
Hysteresis (%)	< 6			
Repeatability (%)	< 3			
Rated current (mA)	800			
Hydraulic fluid		Mineral oil, phosphate-ester		
Viscosity (mm ² /s)	2.8~100			
Fluid temp. (°C)	-20~70			
Coil resistance (Ω)	19.5			
Cleanliness	Filter is recommended for the highest fluid pollution degree;the lowest specific filtration resistance according to ISO 4406 (C) 20/18/15.			

Proportional Electro-hydraulic Directional Valve(BFWH)

03 Model characteristic curves (Measured at $v=36 \times 10^{-6} \text{m}^2/\text{S}$ $t=50^\circ\text{C}$)

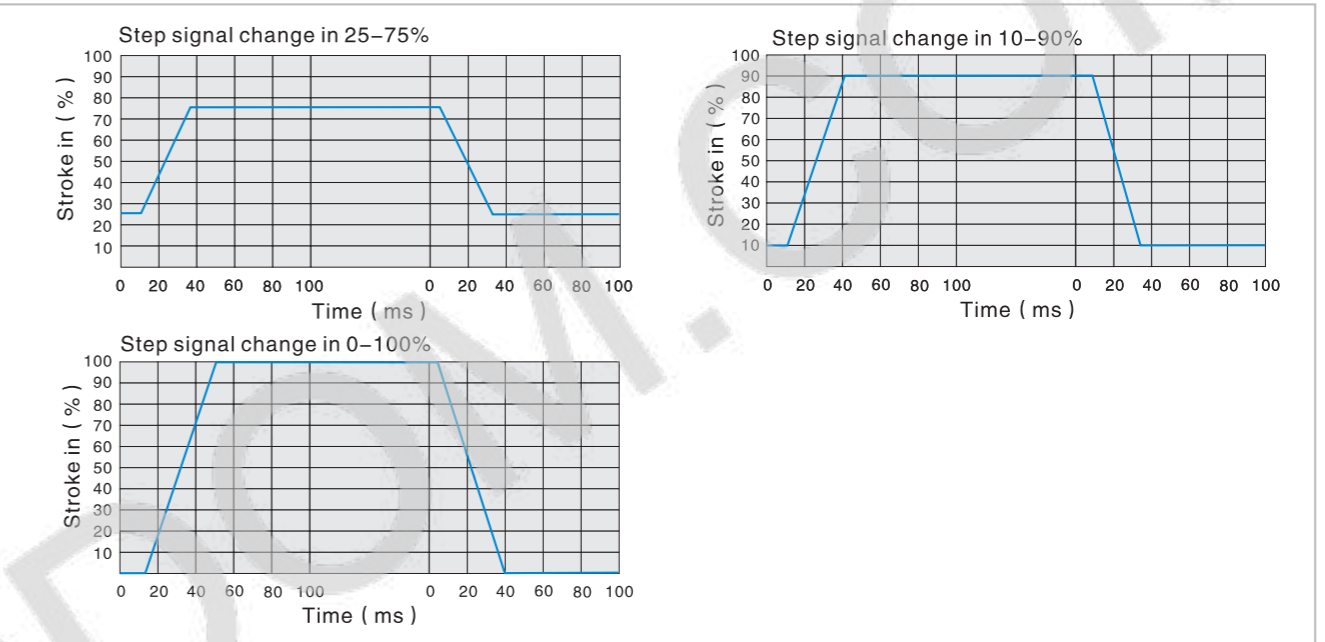

Model instruction

BFWH - * - * - * - * - 5X *

Proportional electro-hydraulic directional valve

Specification
03 DN 10
04 DN 16
06 DN 25

Symbol: (See BFW)

Control oil:
Omit Intl cntrl intl disch
X Extl cntrl intl disch
Y Intl cntrl extl disch
XY Extl cntrl extl disch

Remarks

Design serial number

Nominal flow (based on 1MPa pressure drop)

Specification	03	04	06
25	25 l/min		
50	50 l/min		
85	85 l/min		
100	100 l/min		
150	150 l/min		
270	270 l/min		
325	325 l/min		

03 Model characteristic curves (Measured at $v=36 \times 10^{-6} \text{m}^2/\text{S}$ $t=50^\circ\text{C}$)

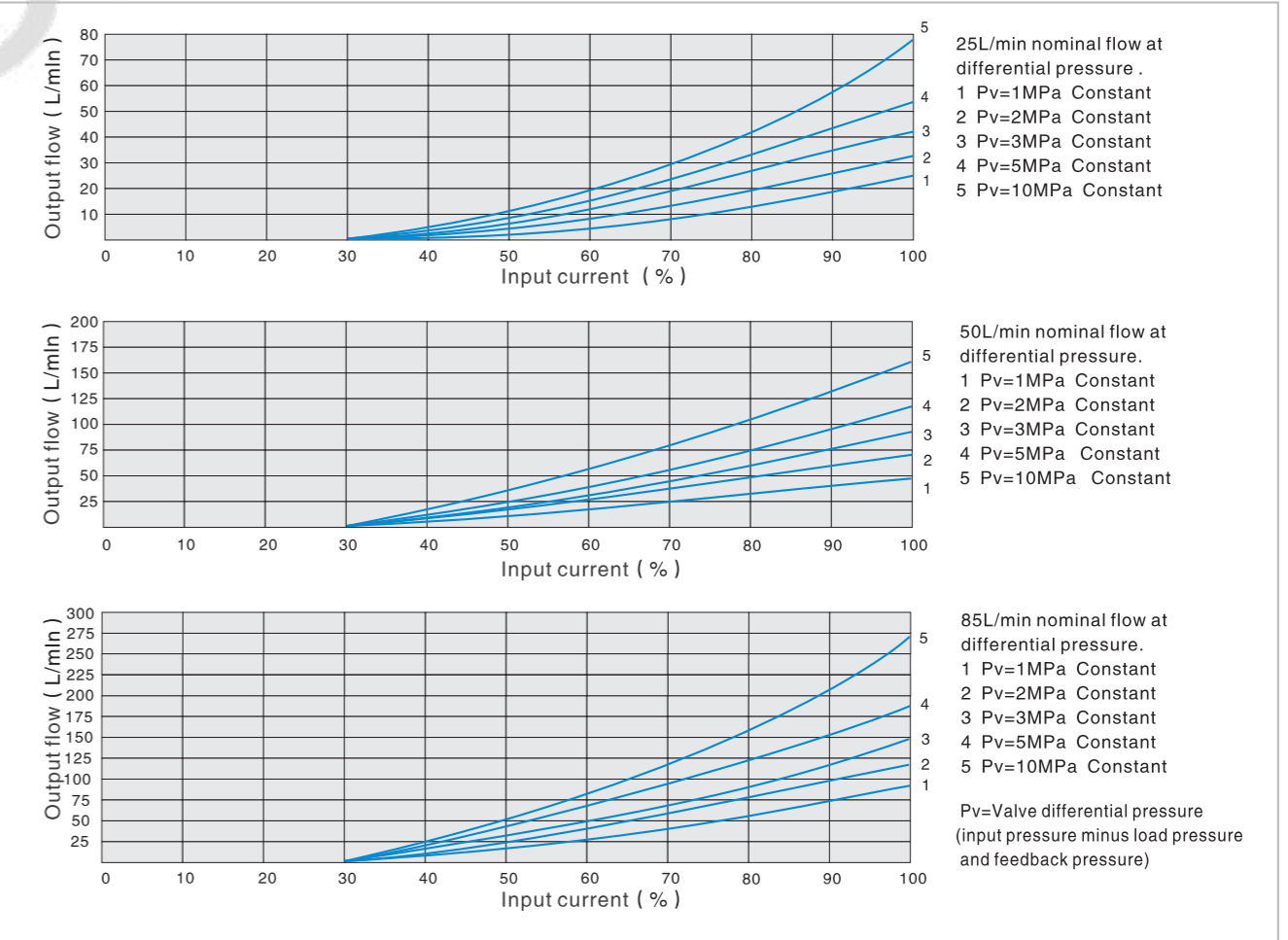

Proportional Electro-hydraulic Directional Valve(BFWH)

04 Model characteristic curves (Measured at $v=36 \times 10^{-6} \text{m}^2/\text{S}$ $t=50^\circ\text{C}$)

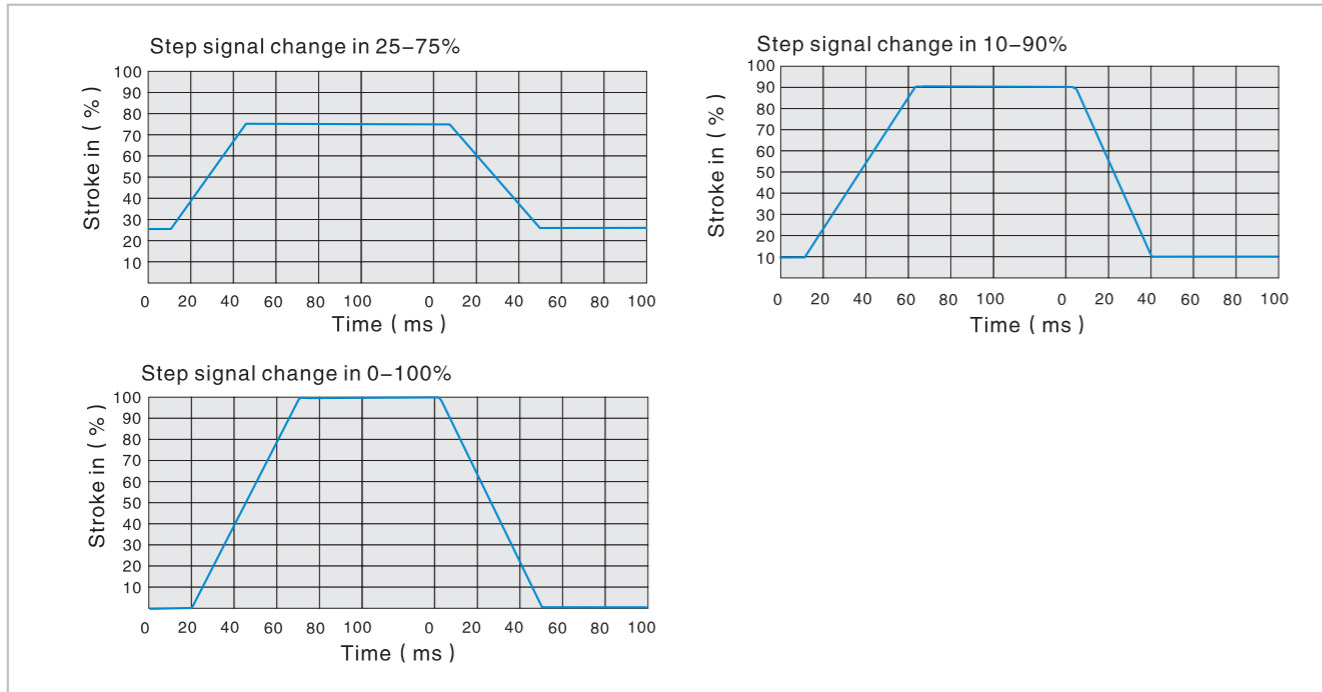

04 Model characteristic curves (Measured at $v=36 \times 10^{-6} \text{m}^2/\text{S}$ $t=50^\circ\text{C}$)

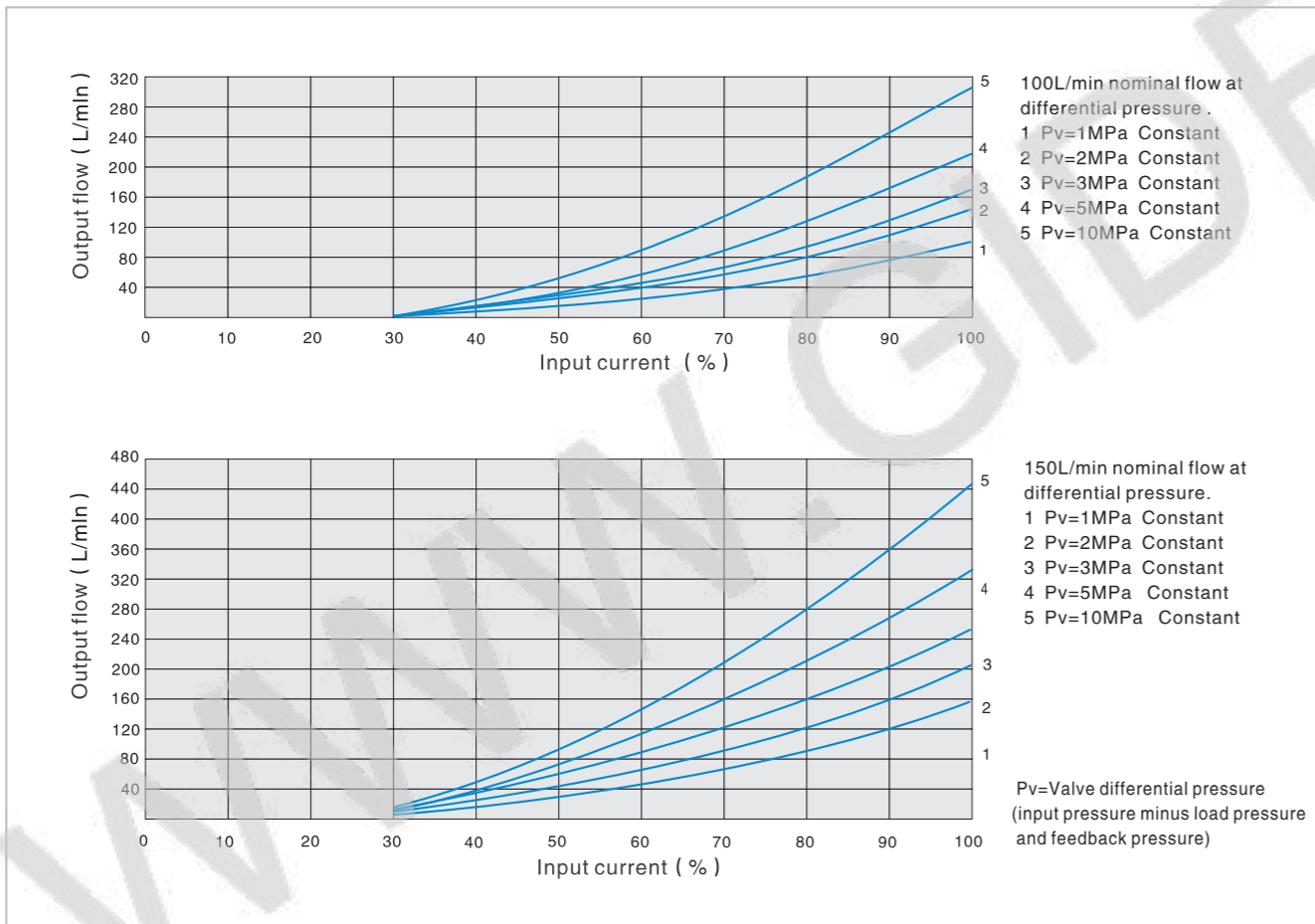

Proportional Electro-hydraulic Directional Valve(BFWH)

06 Model characteristic curves (Measured at $v=36 \times 10^{-6} \text{m}^2/\text{S}$ $t=50^\circ\text{C}$)

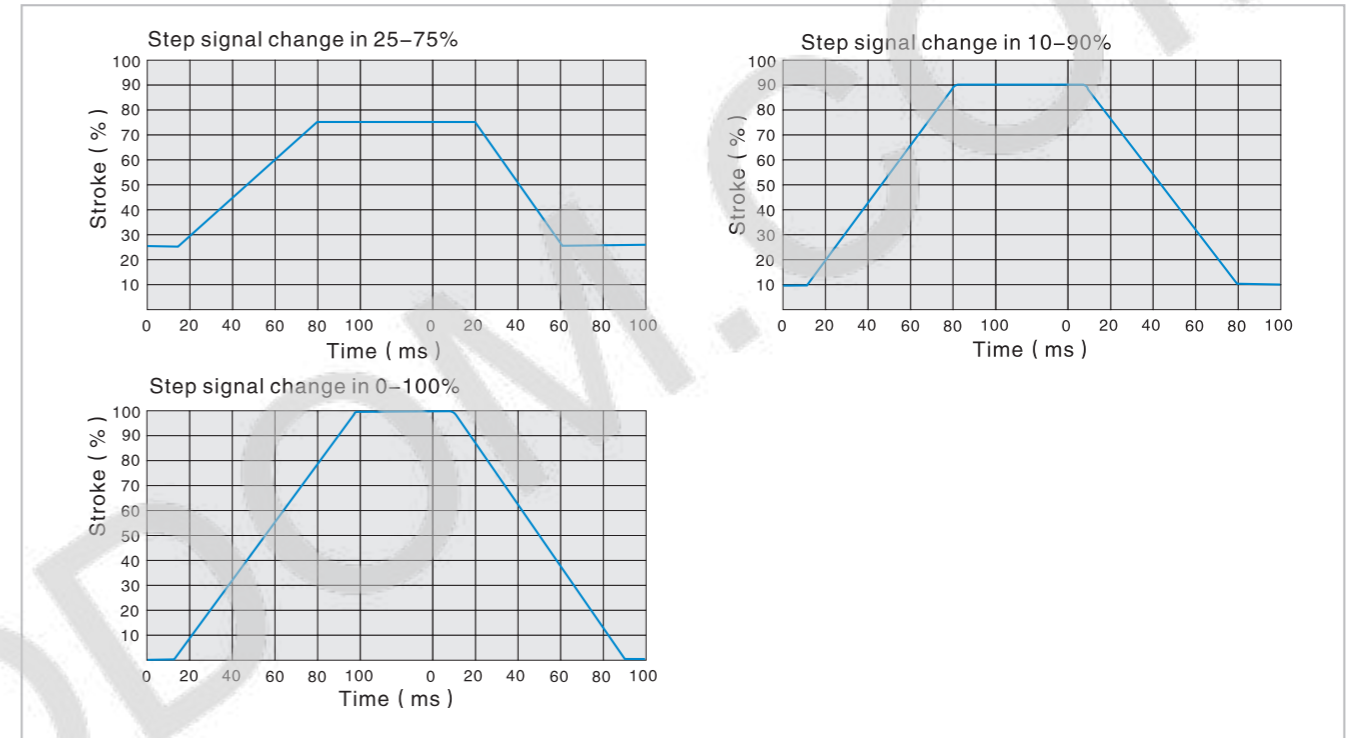

06 Model characteristic curves (Measured at $v=36 \times 10^{-6} \text{m}^2/\text{S}$ $t=50^\circ\text{C}$)

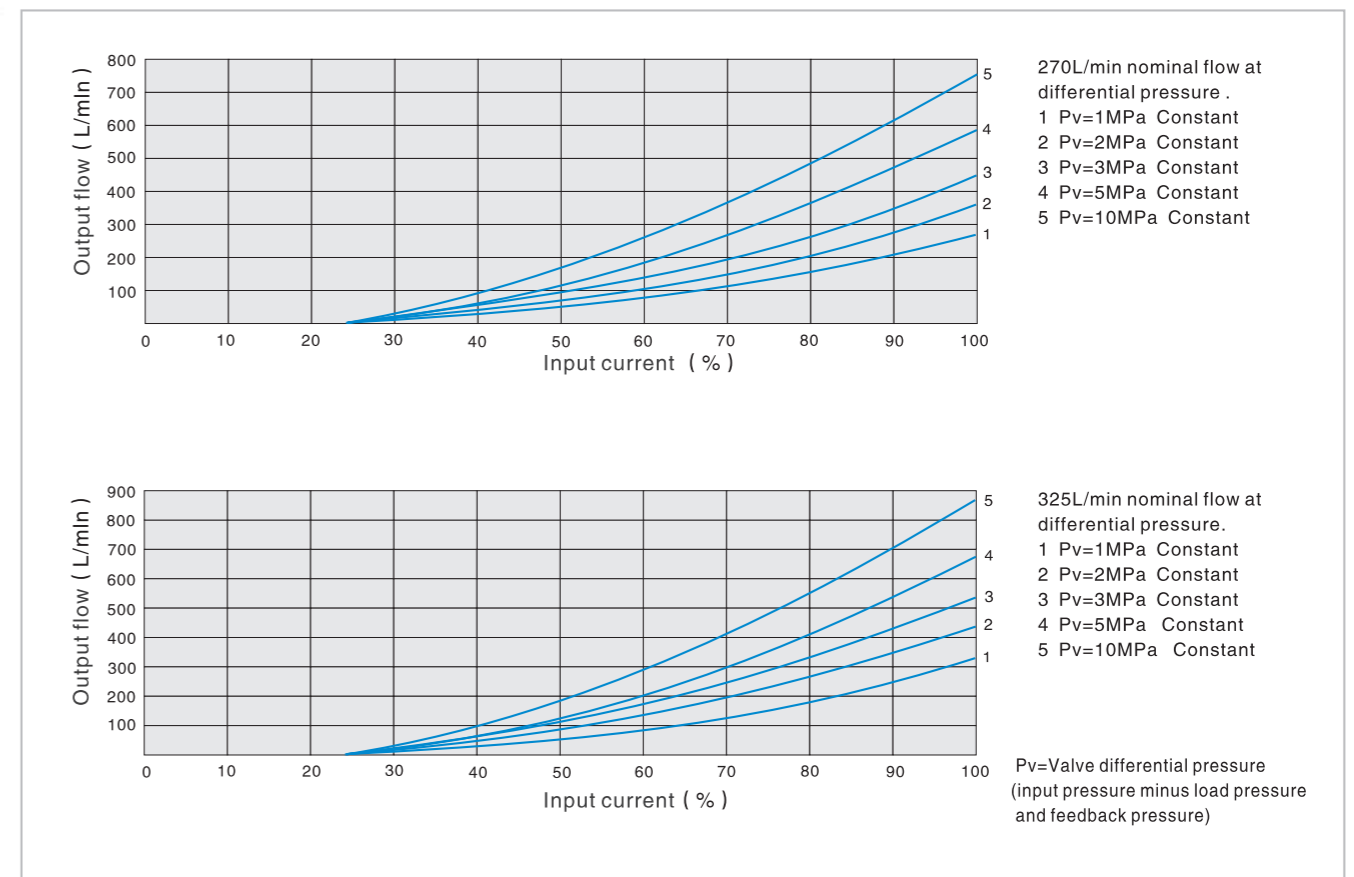

Proportional Electro-hydraulic Directional Valve(BFWH)

External dimensions

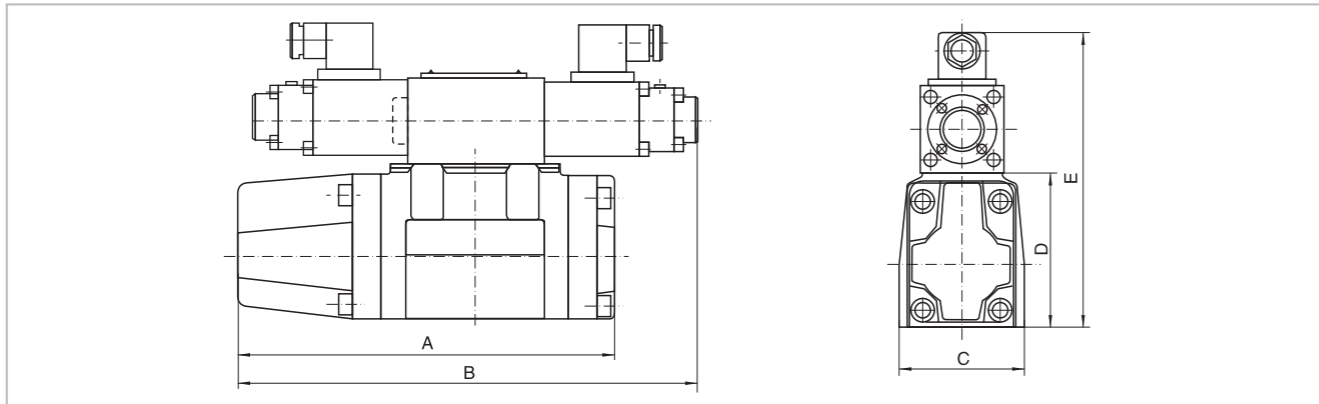

Specification	A	B	C	D	E
BFWH-03	216	250	70	86	171
BFWH-04	250	265	94	95	185
BFWH-06	280	290	120	117.5	202.5

Plate size

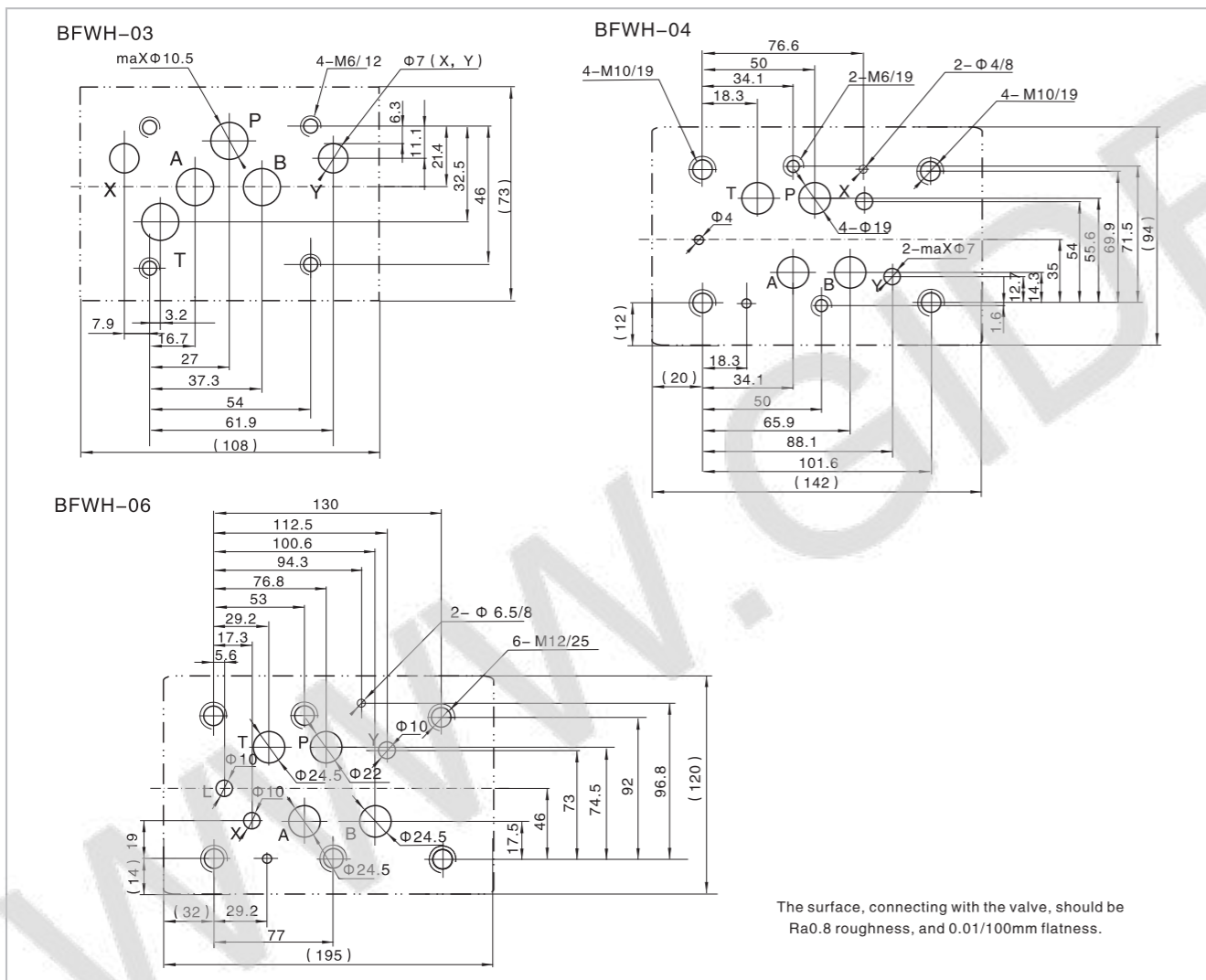

Proportional Directly Operated Relief Valve (BYZ)

Technical specification



Maximum pressure (MPa)	31.5
Maximum flow (l/min)	2
Minimum flow (l/min)	0.7
Rated current (mA)	800
Coil resistance (Ω)	19.5
Hysteresis (%)	< ±1.5
Repeatability (%)	< ±1
Cleanliness	Filter is recommended for the highest fluid pollution degree; the lowest specific filtration resistance according to ISO 4406 (C) 20/18/15.

The valve is a direct operated valve controlled by proportional solenoid, it is mainly used for small hydraulic system according to input current, and always is used to be taken as the pilot relief valve of a second pressure valve.

Model instruction

BYZ - 02 - * - 7X - *		Remarks
Proportional directly operated relief valve		Design serial number
Specification 02 DN 6		Working pressure 7 7MPa 16 16MPa 25 25MPa 31.5 31.5MPa

Code symbol

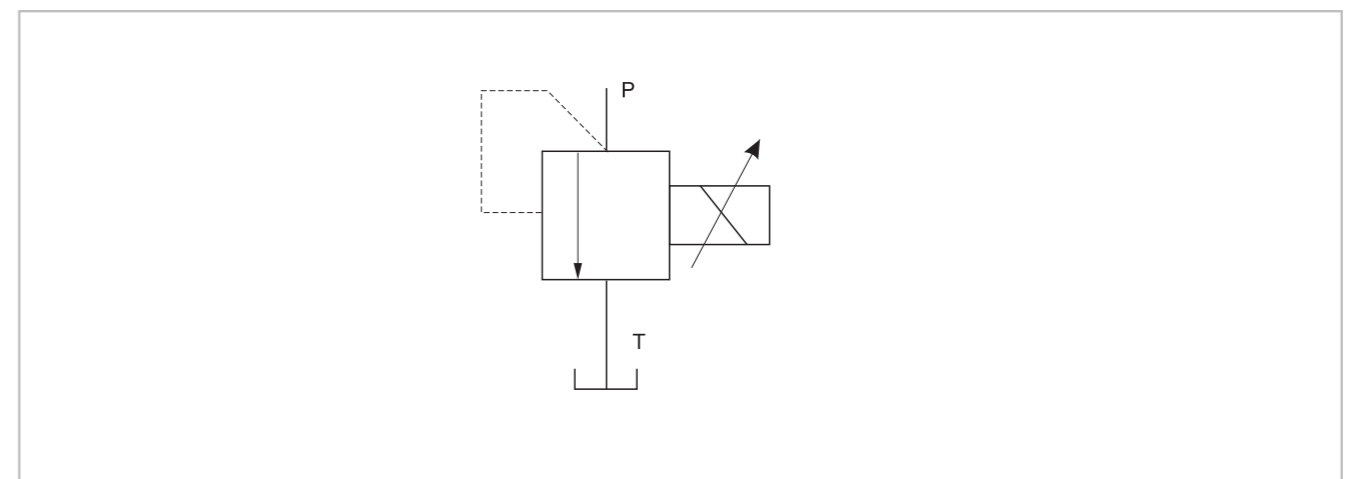

Proportional Directly Operated Relief Valve (BYZ)

02 Model Characteristic Curves (Measured at $v=36 \times 10^{-6} \text{m}^2/\text{S}$ $t=50^\circ\text{C}$)

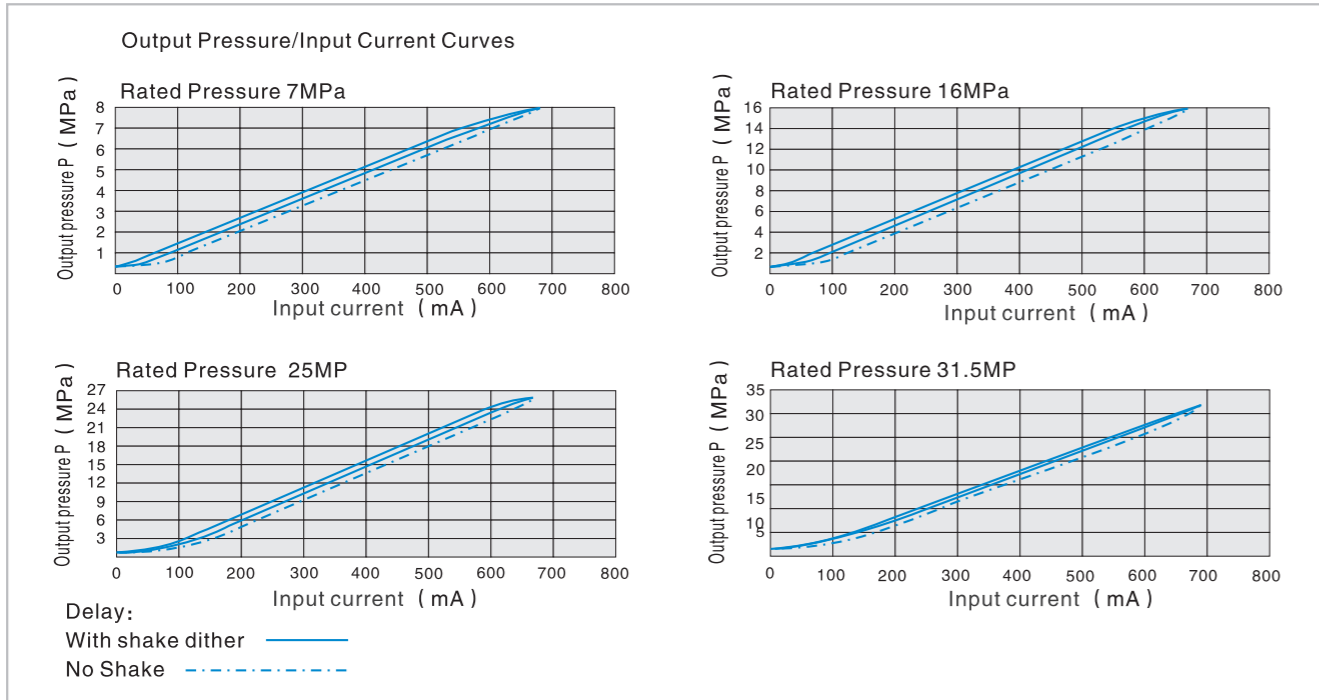

70 External dimensions

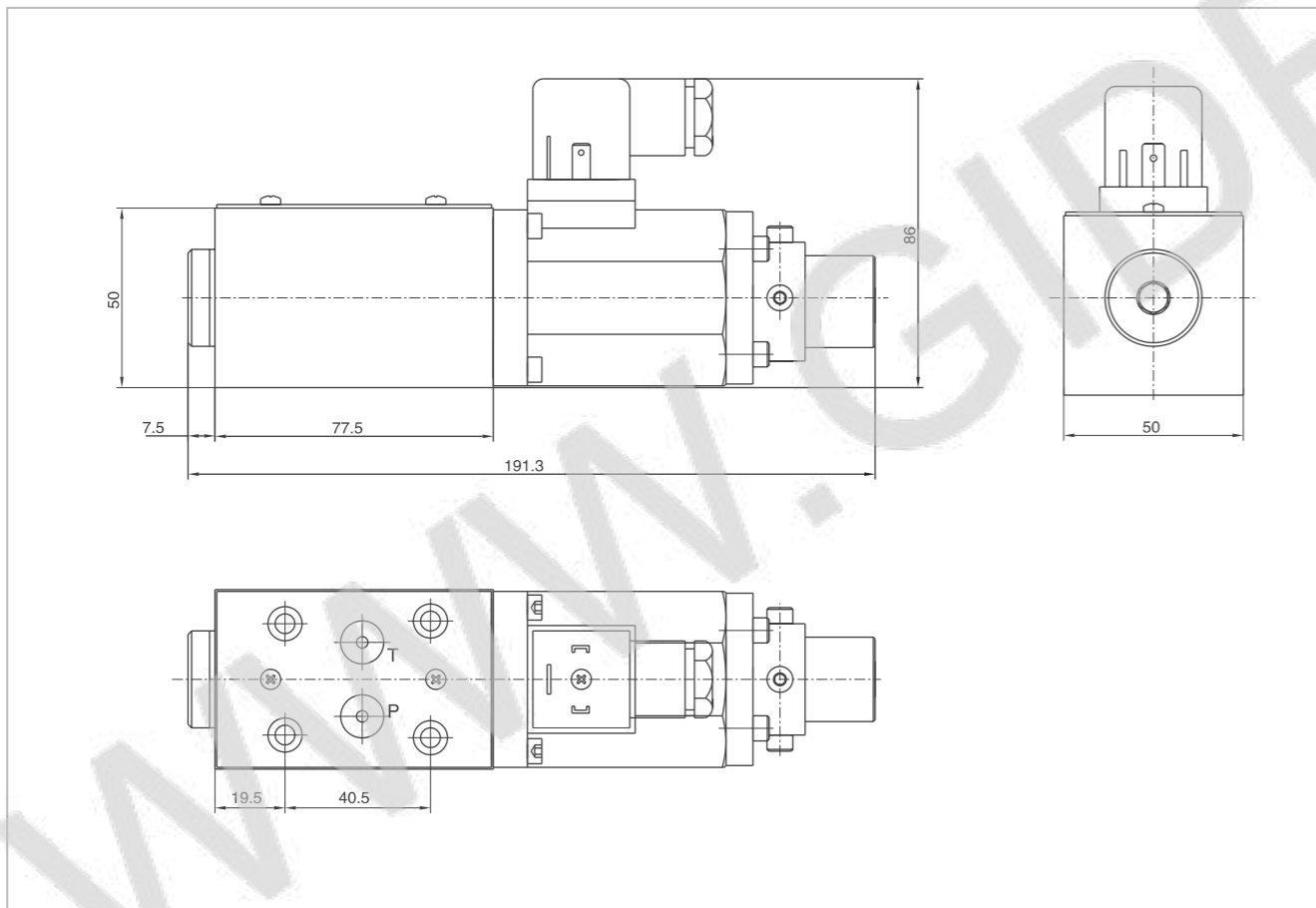

Proportional Directly Operated Relief Valve (BYZ)

Plate size

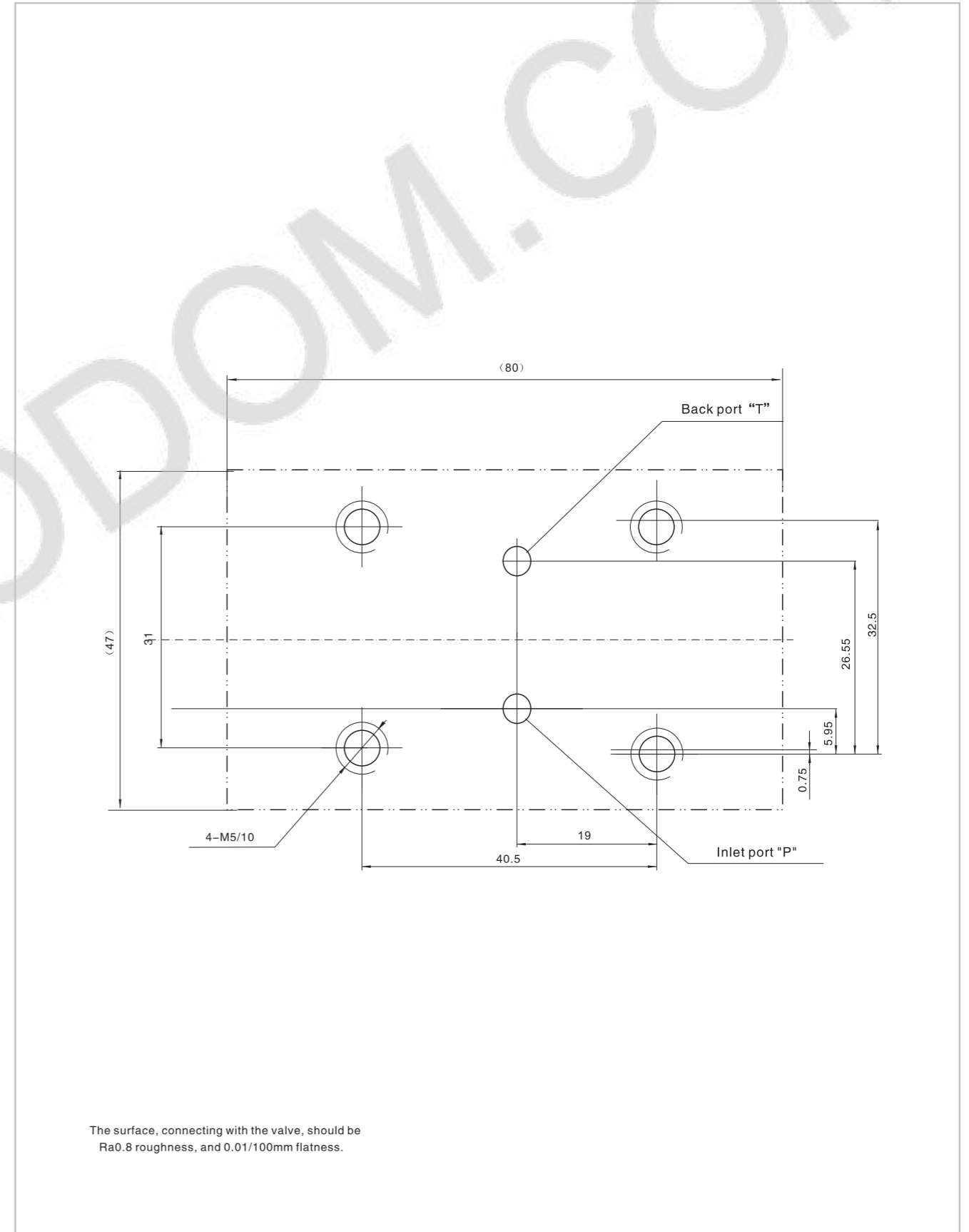

Proportional Pilot-operated Relief Valve (BY)

Technical specification



Specification	03	06
Maximum pressure (MPa)	31.5	31.5
Maximum flow (L/min)	80	200
Minimum flow (L/min)	3	
Rated current (mA)	800	
Coil resistance (Ω)	10~19.5	
Hysteresis (%)	< ±1.5	
Repeatability (%)	< ±2	
Cleanliness	Filter is recommended for the highest fluid pollution degree; the lowest specific filtration resistance according to ISO 4406 (C) 20/18/15.	

Comprised of proportional directly-operated relief valve, pressure limiting valve and low-noise relief valve.

Model instruction

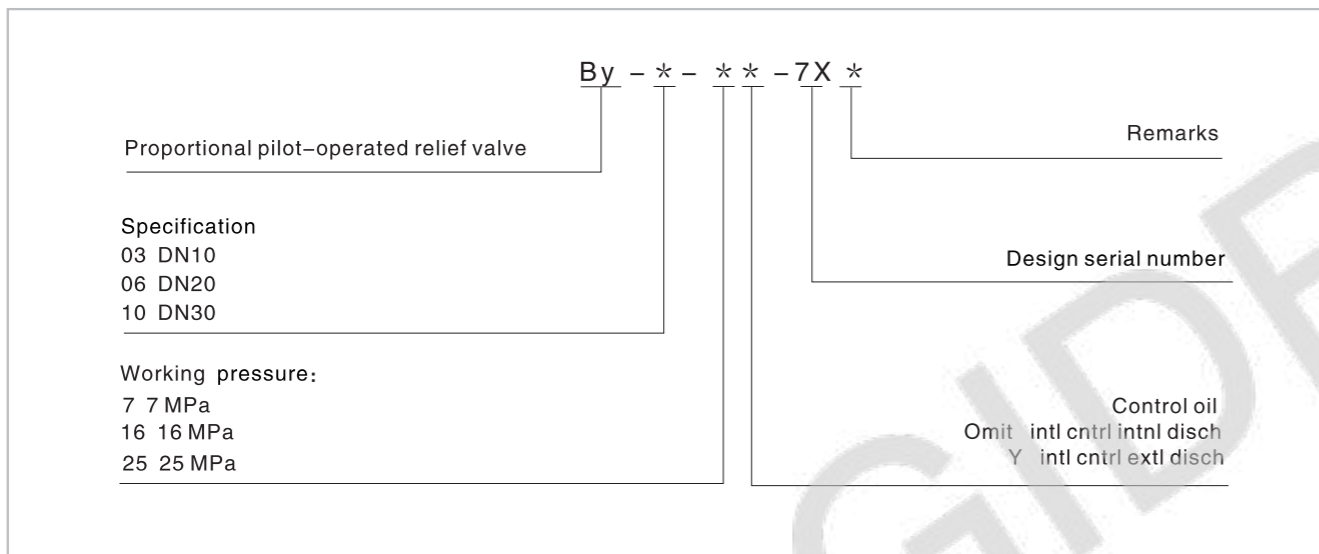

Code symbol

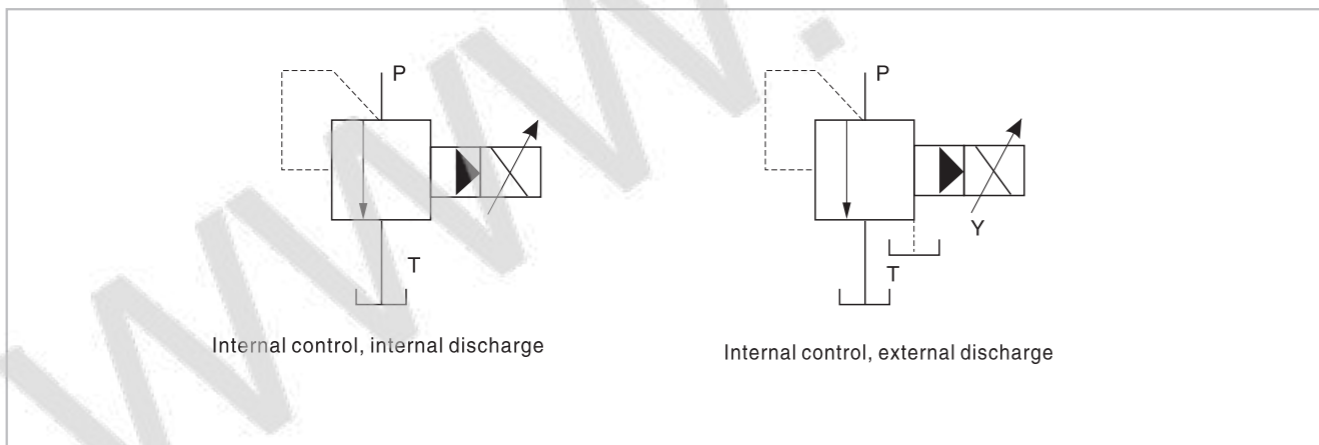

Proportional Pilot-operated Relief Valve (BY)

03、06、10 Model characteristic curves (Testing Condition $v=36 \times 10^{-6} \text{m}^2/\text{S}$ $t=50^\circ\text{C}$)

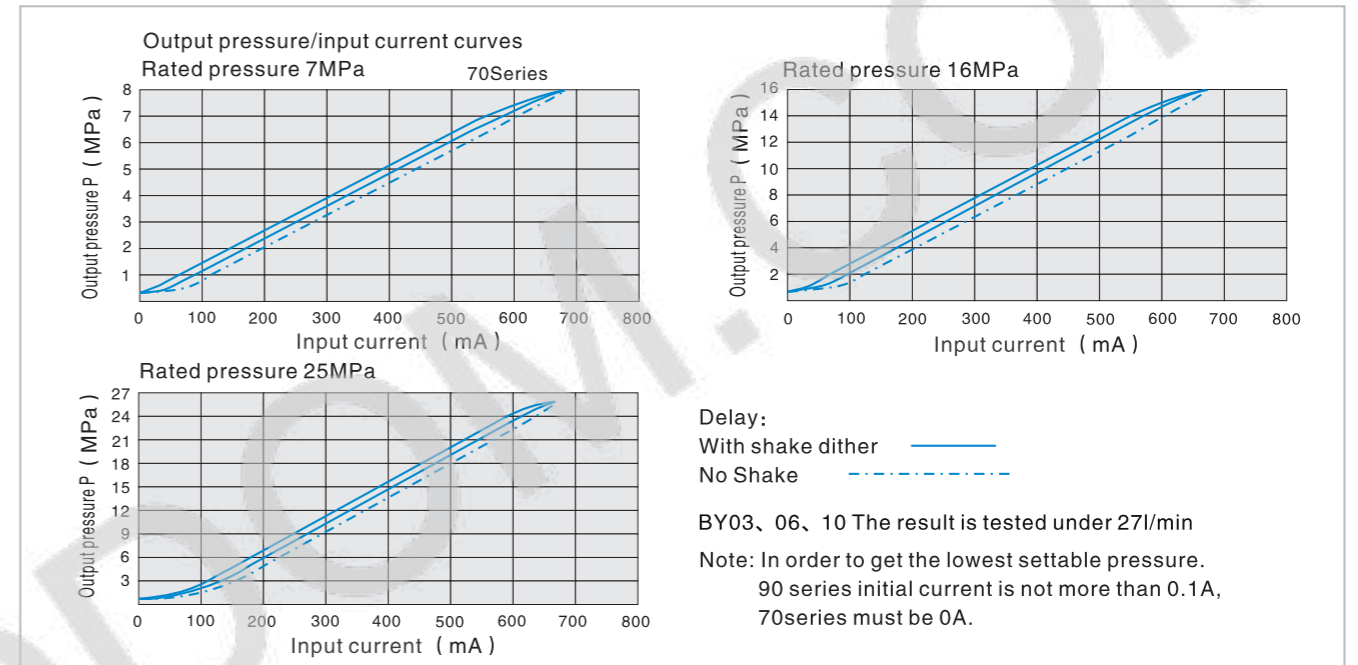

Characteristic curves (Testing Condition $v=36 \times 10^{-6} \text{m}^2/\text{S}$ $t=50^\circ\text{C}$)

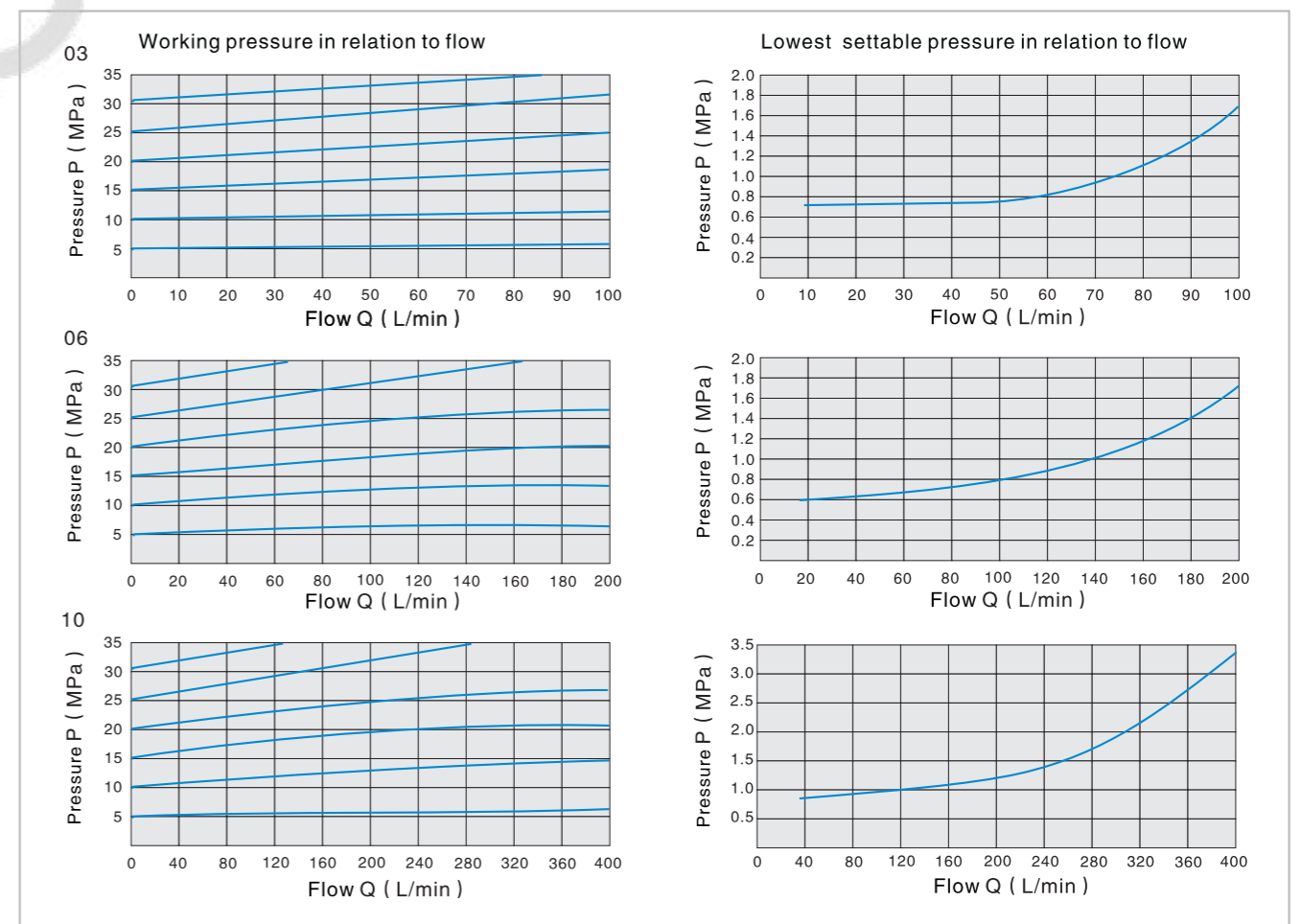

Proportional Pilot-operated Relief Valve (BY)

External dimensions

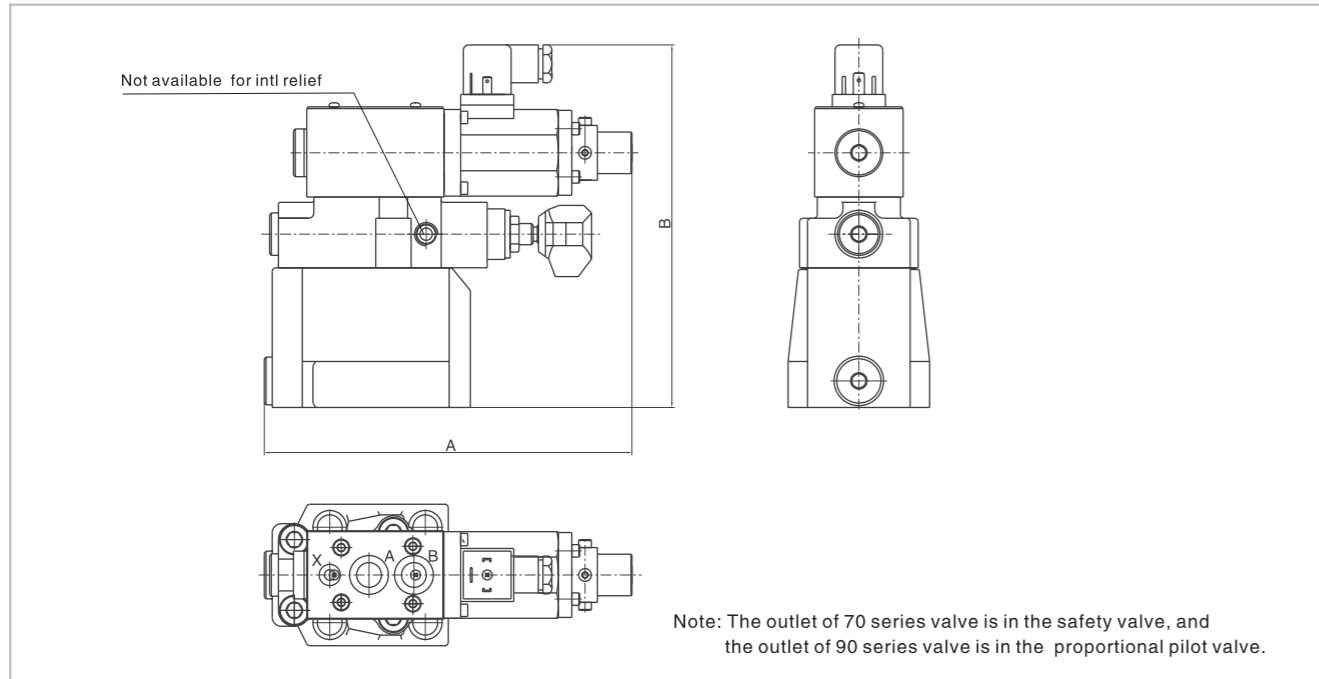
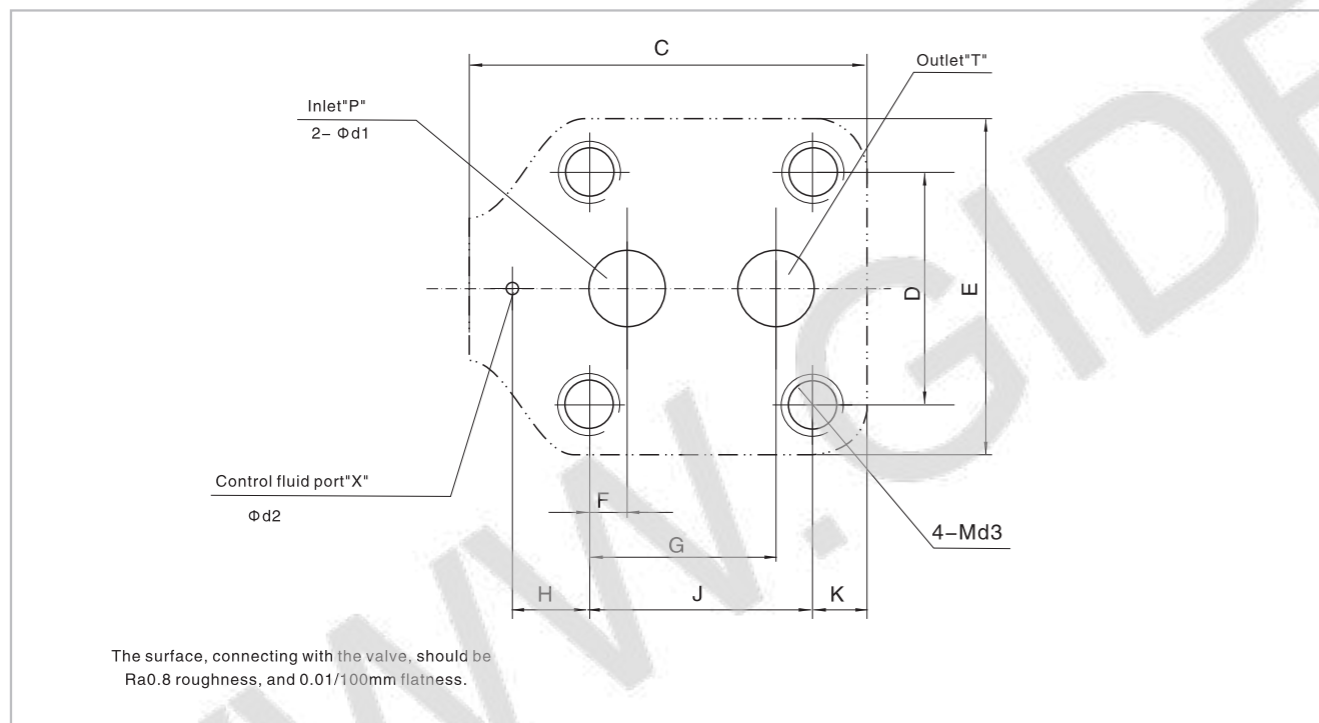

Plate size



Specification	A	B	C	D	E	F	G	H	J	K	d1	d2	d3
BY-03	197	193	112	54	80	22.2	47.6	0	54	25.8	12	6	12
BY-06	197	197	119	69.8	102	11.1	55.6	23.8	66.7	16.3	25	6	16
BY-10	197	200	150	82.5	116	12.7	76.2	31.7	89	18	32	6	18

Attention: set the deflate hole upward to exhaust air from the pipe

Proportional Pilot-operated Pressure Reducing Valve (BYJ)

Technical specification

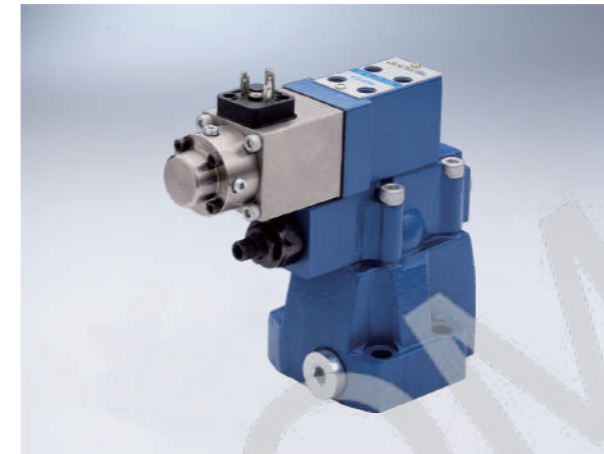

Specification	03	06
Maximum pressure (MPa)	31.5	31.5
Maximum flow (l/min)	150	300
Secondary pressure Regulating range (MPa)	See model description	
Rated current (mA)	800	
Coil resistance (Ω)	19.5	
Hysteresis (%)	< ±2.5	
Repeatability (%)	< ±2	
Cleanliness	Filter is recommended for the highest fluid pollution degree; the lowest specific filtration resistance according to ISO 4406 (C) 20/18/15.	

Comprised of proportional directly-operated relief valve, pressure limiting valve and reducing valve, this product controls a secondary pressure from the system pressure according to value of input current.

Model instruction

	BYJ - * - * * Y - 9 X *	Remarks
Proportional pilot-operated pressure reducing valve		
Specification 03 DN10 06 DN20		Design serial number
Secondary pressure regulating range 7 7MPa 16 16MPa 25 25MPa		Control oil Y intl cntrl extl disch
	Default D	Without check valve With check valve

Code symbol

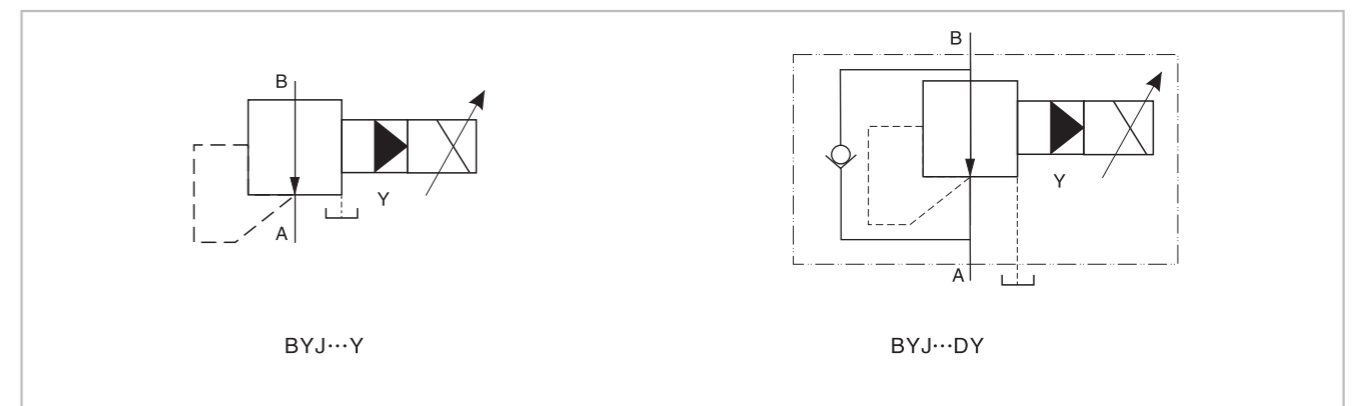

Proportional Pilot-operated Pressure Reducing Valve(BYJ)

03、06、10 Model characteristic curves (Measured at $\nu=36 \times 10^{-6} \text{m}^2/\text{S}$ $t=50^\circ\text{C}$)

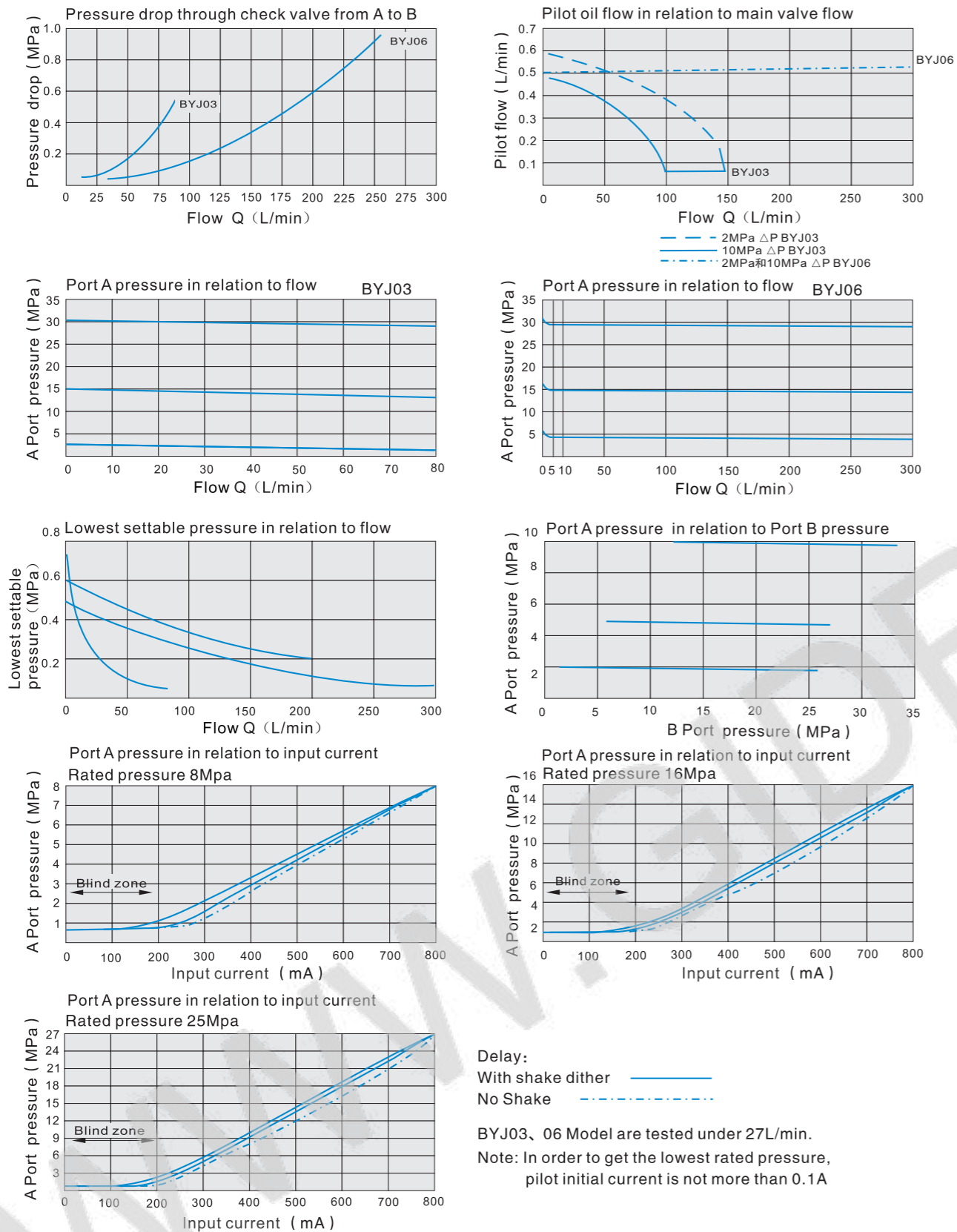

Proportional Pilot-operated Pressure Reducing Valve(BYJ)

External dimensions

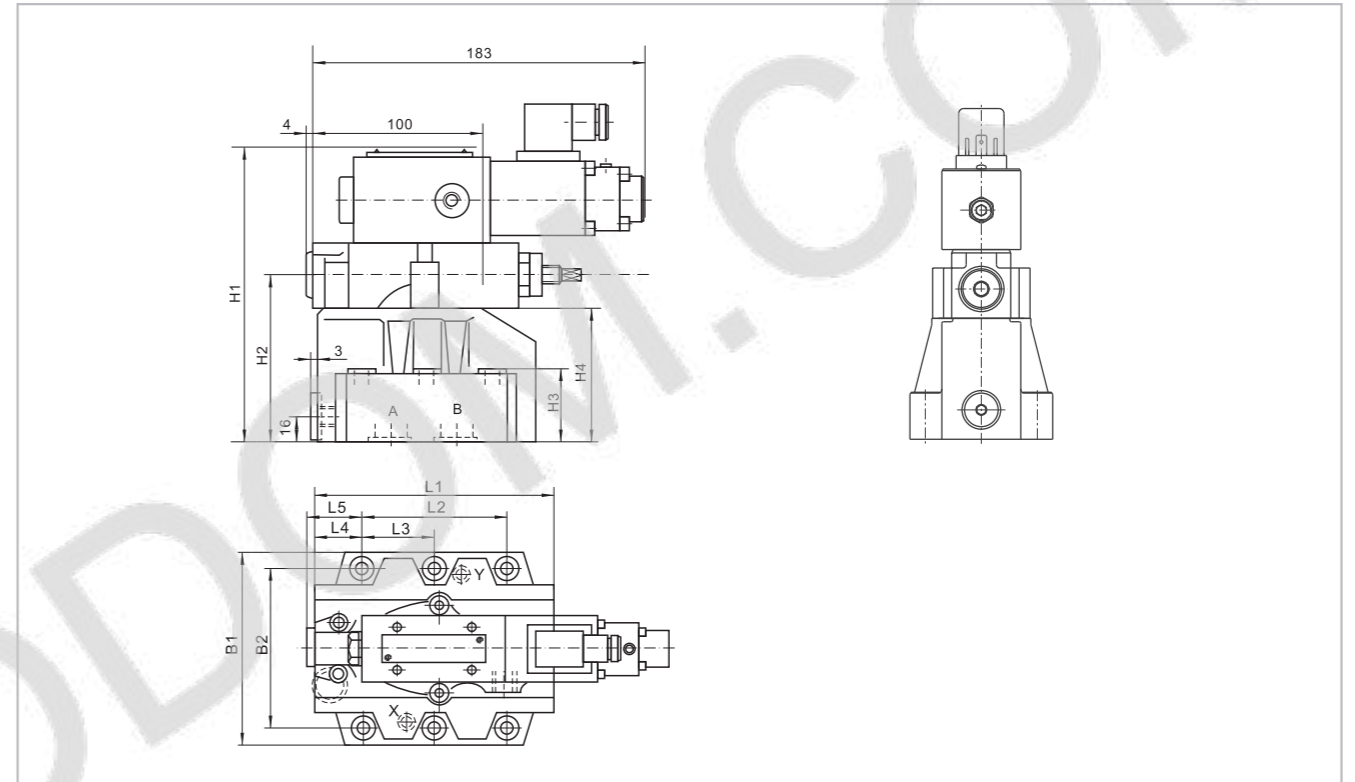
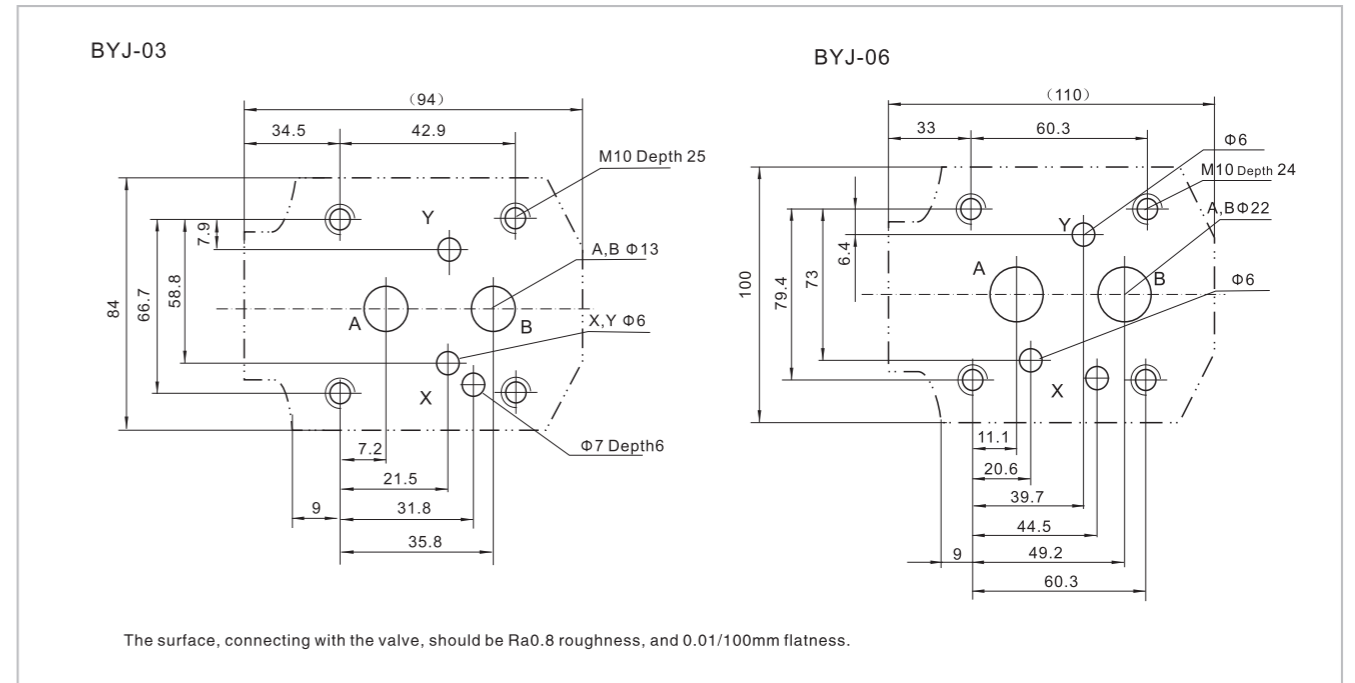

Plate size



The surface, connecting with the valve, should be Ra0.8 roughness, and 0.01/100mm flatness.

Specification	B1	B2	H1	H2	H3	H4	L1	L2	L3	L4	L5
BYJ-03	85	66.7	190	92	28	72	90	42.9	-	35.5	34.5
BYJ-06	102	79.4	200	102	38	82	112	60.3	-	33.5	37

Proportional Electro-hydraulic Control P-Q Valve(BYLZ)

Technical specification



This proportional valve adopts two electrical loops to control pressure and flow of hydraulic system respectively. Using very small pressure drop to track load pressure and control the pump pressure, it is an energy-saving valve.

Model	BYLZ-02-*-*	BYLZ-03-*-*	BYLZ-06-250-*	
Maximum pressure (MPa)	31.5			
Maximum flow (l/min)	40	160	250	
Flow range (l/min)	1-40	2-160	3-250	
Pressure control	Rated current (mA)	800		
	Coil resistance (Ω)	19.5	43.5	43.5
	P Differential(MPa)	0.6	0.6	0.7
	Hysteresis (%)	< 5	< 7	< 7
	Repeatability (%)	< 1		
Flow control	Pressure Range (Mpa)	16:1.5-16 25:1.5-25 31.5:1.5-31.5	16:1.5-16 25:1.5-25 31.5:1.5-31.5	16:1.5-16 25:1.5-25 31.5:1.5-31.5
	Rated current (mA)	800		
	Coil resistance (Ω)	10	10	10
	Hysteresis (%)	< 3		
	Repeatability (%)	< 1		
Cleanliness	Filter is recommended for the highest fluid pollution degree;the lowest specific filtration resistance according to ISO 4406 (C) 20/18/15.			

Proportional Electro-hydraulic Control P-Q Valve(BYLZ)

Code symbol

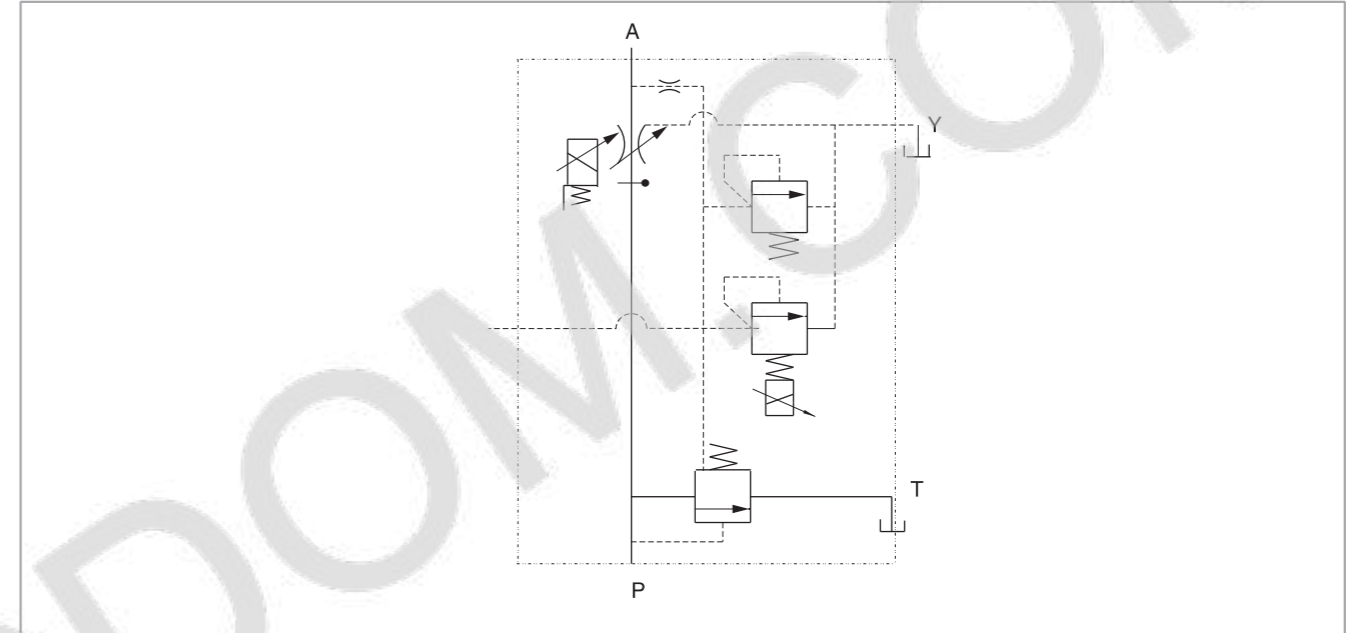

02, 03, 06 Characteristic curves (Measured at $v=36 \times 10^{-6} \text{m}^2/\text{S}$ $t=50^\circ\text{C}$)

Model instruction

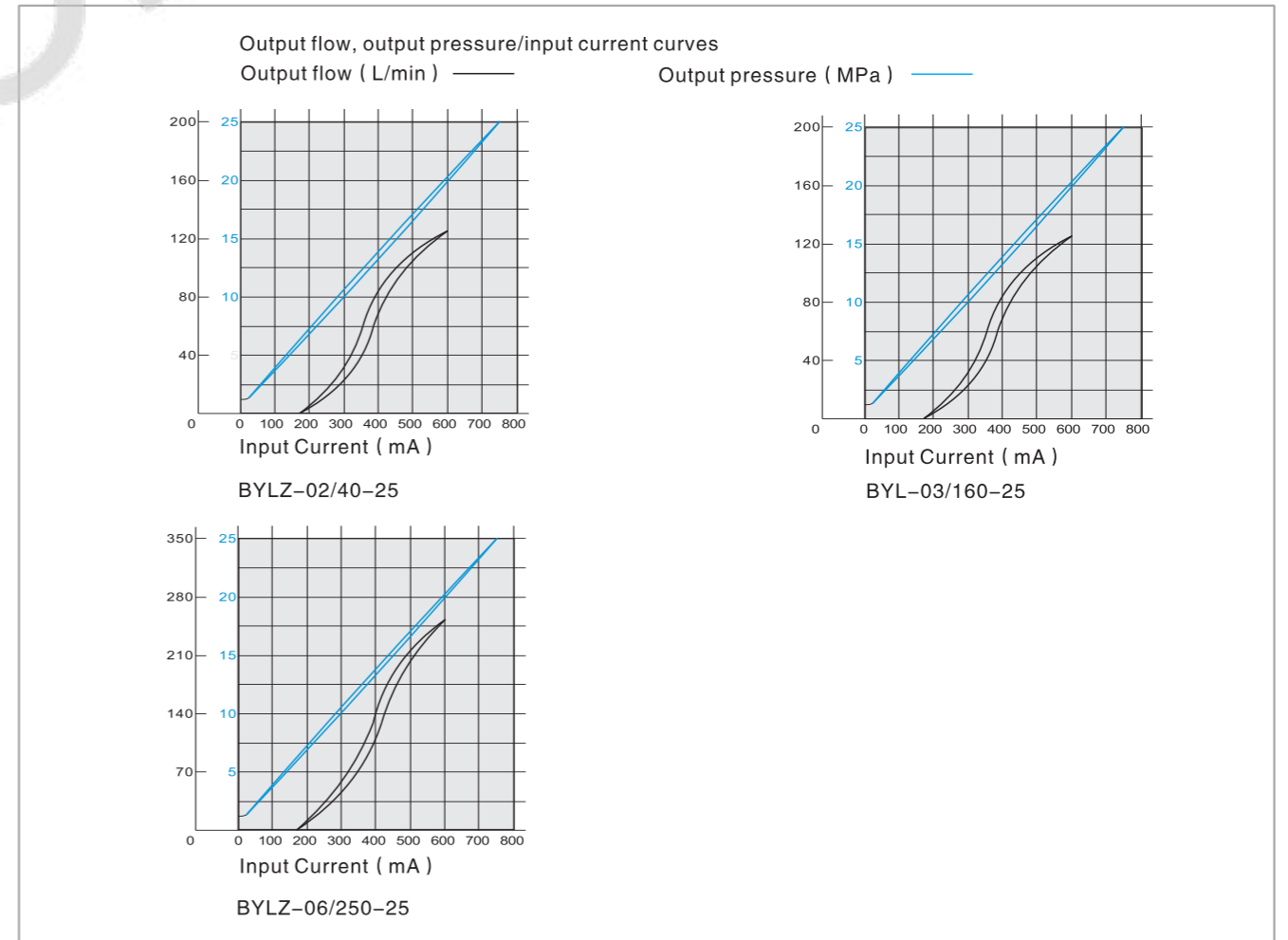
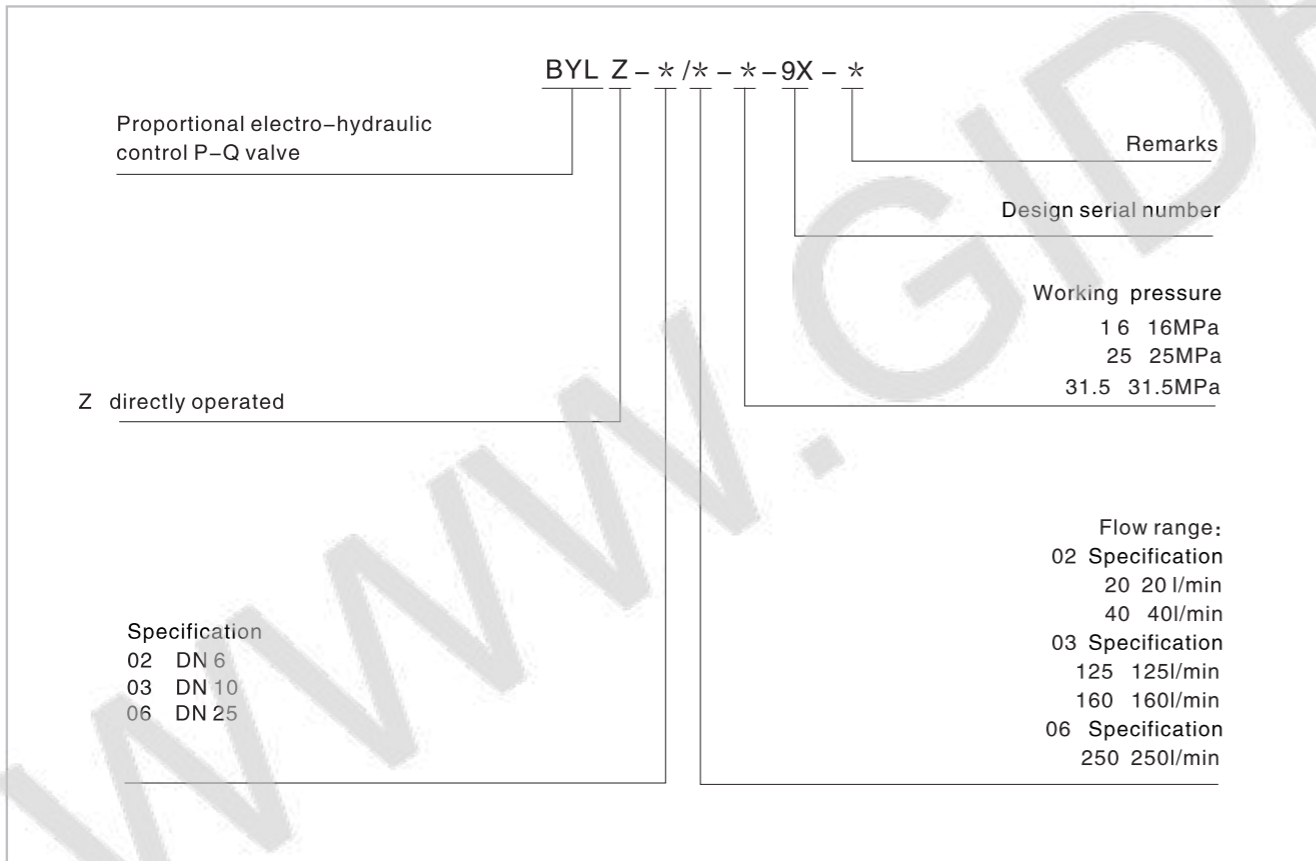

Proportional Electro-hydraulic Control P-Q Valve(BYLZ)

External dimensions

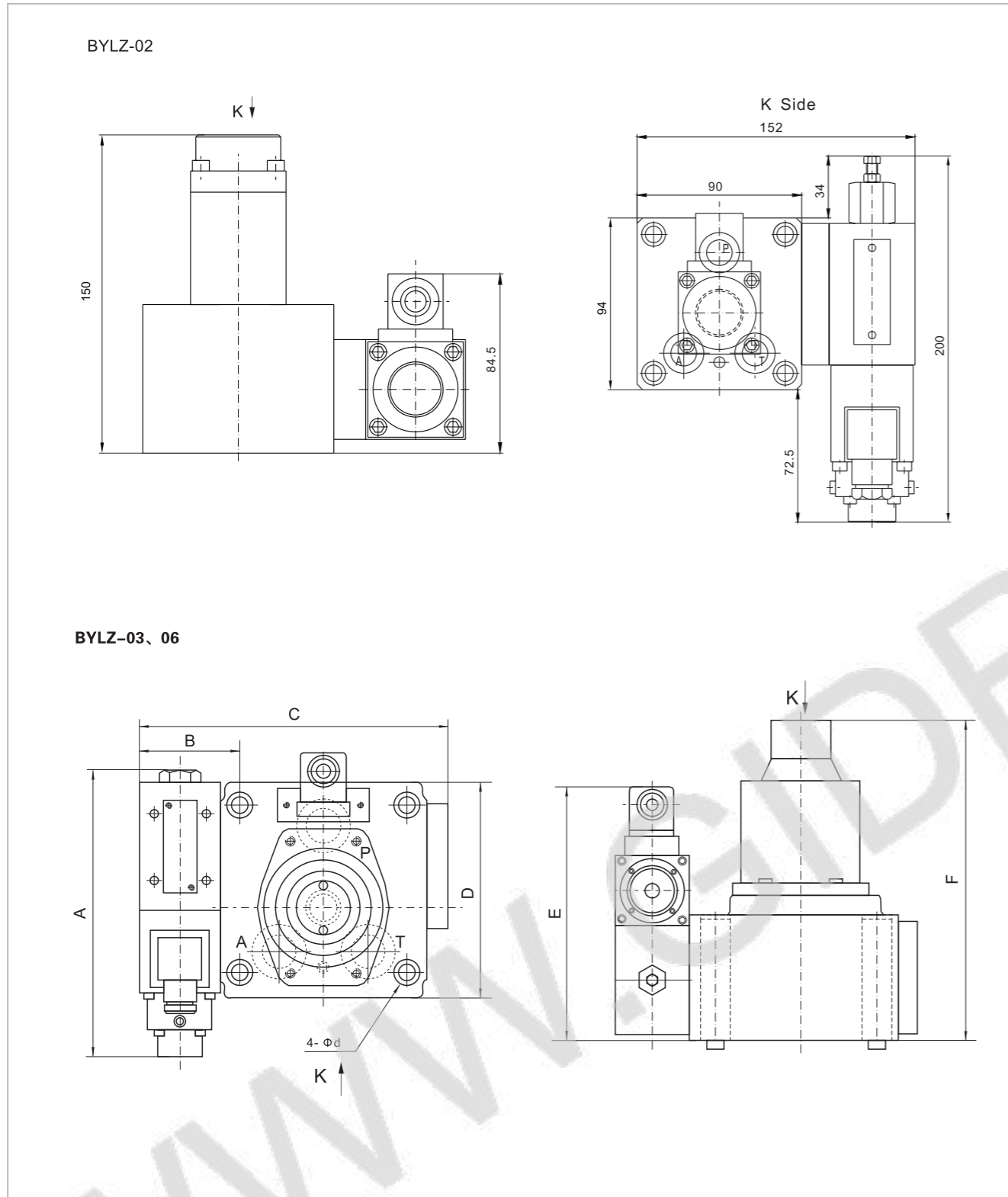

Model	A	B	C	D	E	F	d
BYLZ-03	171	61.7	188	130	171	216	11
BYLZ-06	171	67	247	174	199.5	248	17.5

Proportional Electro-hydraulic Control P-Q Valve(BYLZ)

Plate size

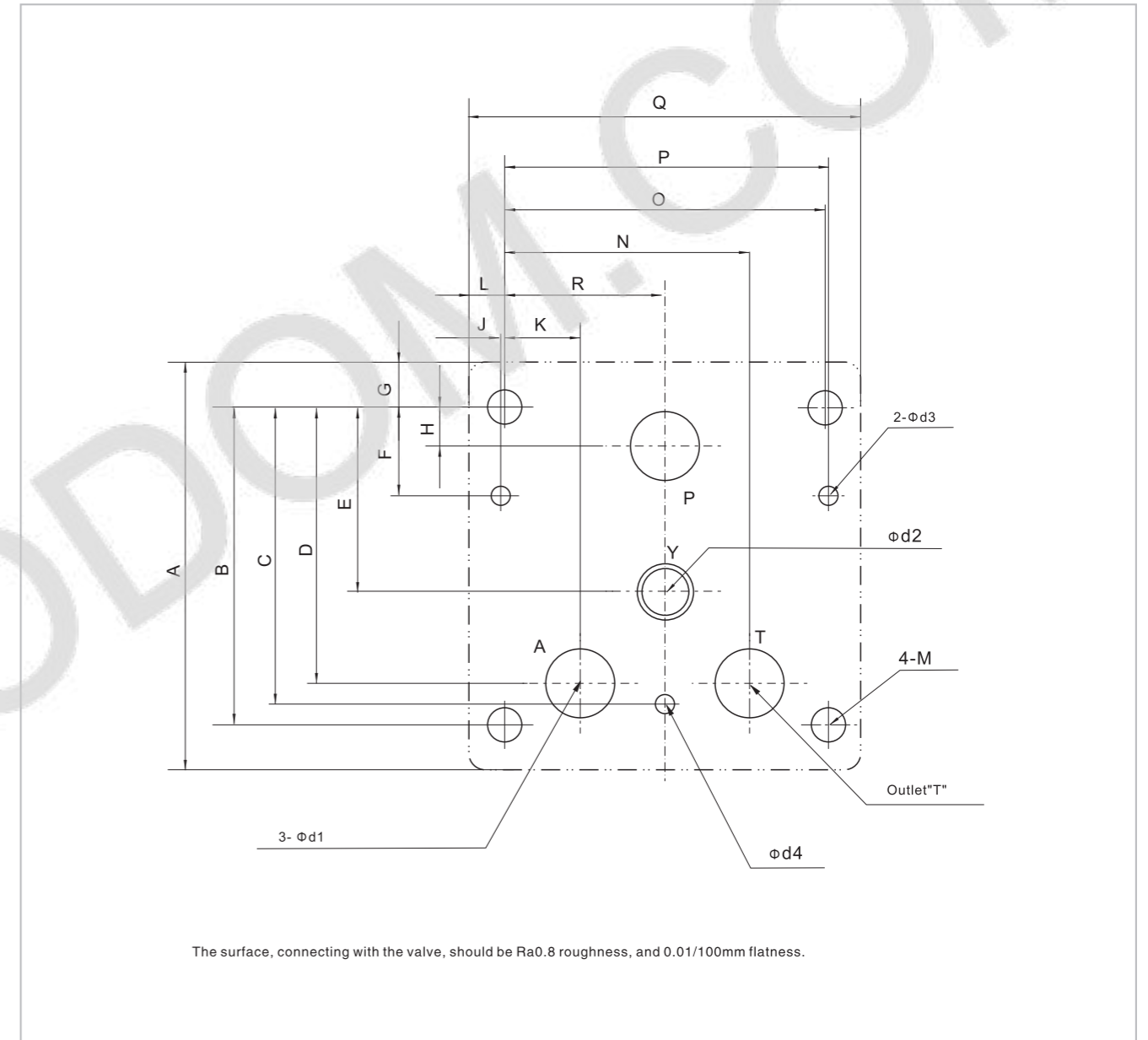

Model	A	B	C	D	E	F	G	H	J	K	L	R	N	O	P	Q	M	d ₁	d ₂	d ₃	d ₄
BYLZ-02	84	76	70	65	43	21.5	9	10	1	16.5	9	36	55.5	72	73	90	M8/14	14	10	7×7L	6
BYLZ-03	130	101.6	95.3	88.9	59	28.6	14.2	12.7	0.8	23.8	11.7	50.8	77.8	101.6	102.4	124	M10/19	23	11	7×7L	6
BYLZ-06	174	133.4	133.4	107	82.2	41.3	24	12.7	1.6	28.1	17	73.1	118.1	146.1	144.5	180	M16/30	29	14	17×10L	6.2

Note in use

- Discharge back press ≤ 0.2MPa
Return back press ≤ 0.5MPa
- Minimum stable flow under controlled pressure
Nominal size 03, 06 ≥ 10 l/min
Nominal size 10 ≥ 15 l/min
- Vent hole orientation can be adjusted freely: Put it upward to vent off the air from the piping.

Thread Type 3-way Proportional Reducing Valve



It's driven by proportional solenoid, convert the input signal into the pressure output signal in proportion.

Technical parameter (please consult factory if your application is out of below range)

Model	HY3DREP-G8	
Mounting	Free, recommended for horizontal installing	
Working temperature (°C)	-20~+50	
Weight (kg)	2.1	

Hydraulic parameter

Max working pressure (MPa)	20.7	
Max flow rate (L/min)	8	
Working fluid	Mineral hydraulic oil, phosphate	
Fluid temp range (°C)	-20~+60	
Viscosity range	20~380	
Hysteresis %	≤3	
Repeatability %	≤1	
Sensibility %	≤1	
Minimum fluid cleanliness	Maximum permissible degree of pressure fluid contamination to NAS 1638 to class 9 Recommended filter $\beta_{10} \geq 75$.	

Electric parameter

Voltage type	Direct current	
Solenoid I-max (A)	2	
Coil resistance at 25°C (Ω)	8	
ED (%)	100	
Max coil temp (°C)	Attainable 150	
Electrical connection	Deutsch DT04-2P	
IP class	IP67	

Thread Type 3-way Proportional Reducing Valve

Ordering code

HY 3DREP - G 8 - D24 - * * *		Remark
3-way proportional reducing valve		
Thread type		
Thread size	8 SAE-8	Sealing Omit NBR seal V FPM seal
Voltage type	D24 DC 24V	Pressure rating 50 5MPa

Hydraulic symbol

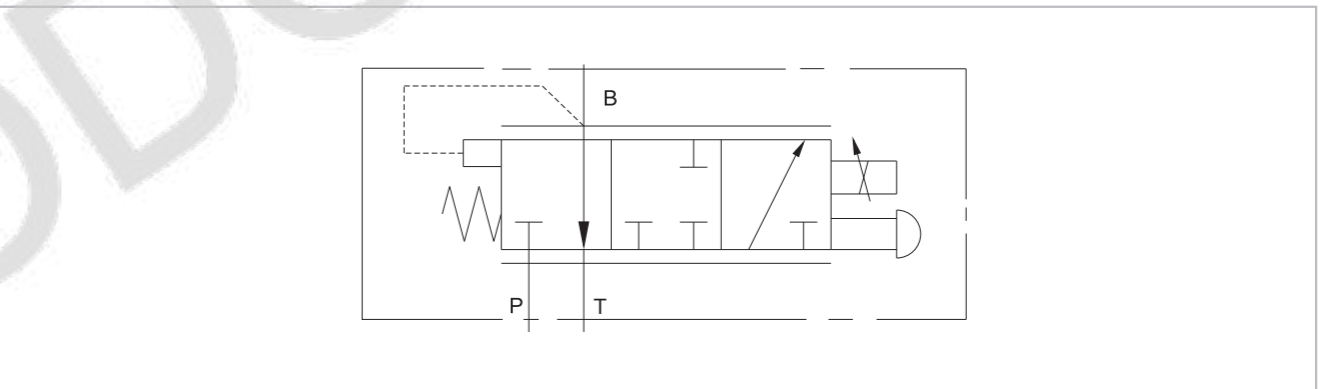

Performance curve

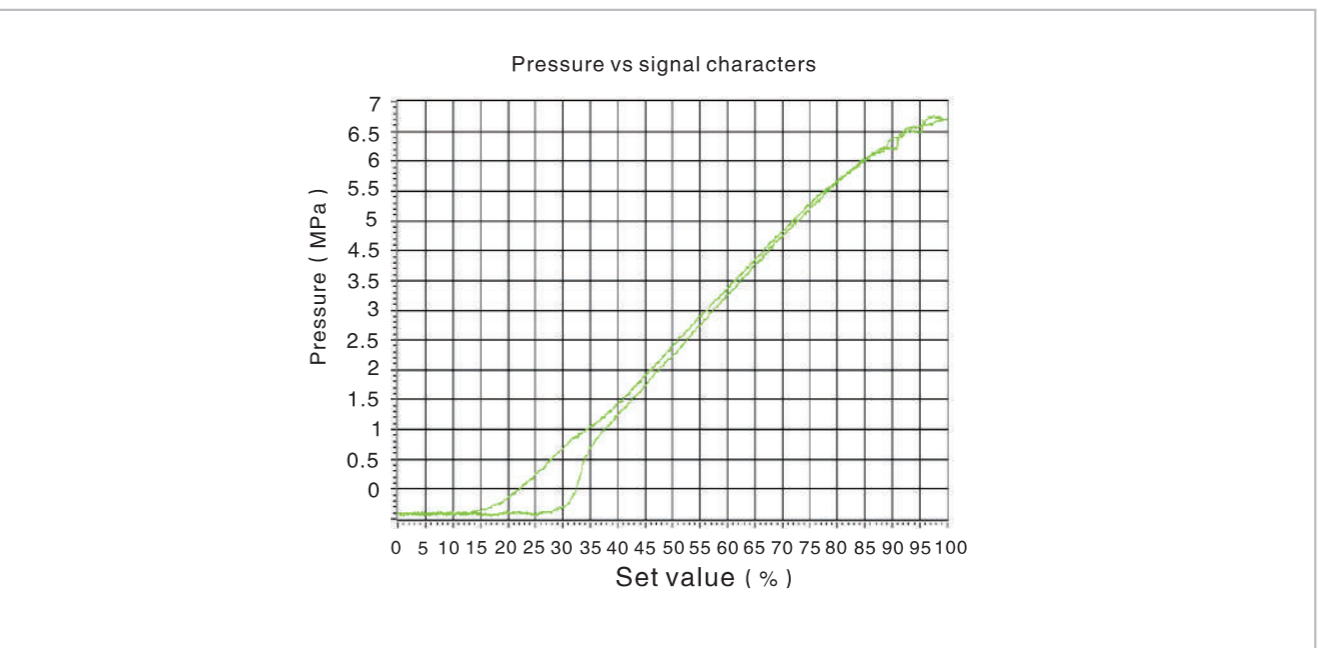

Thread Type 3-way Proportional Reducing Valve

External dimension and thread connection

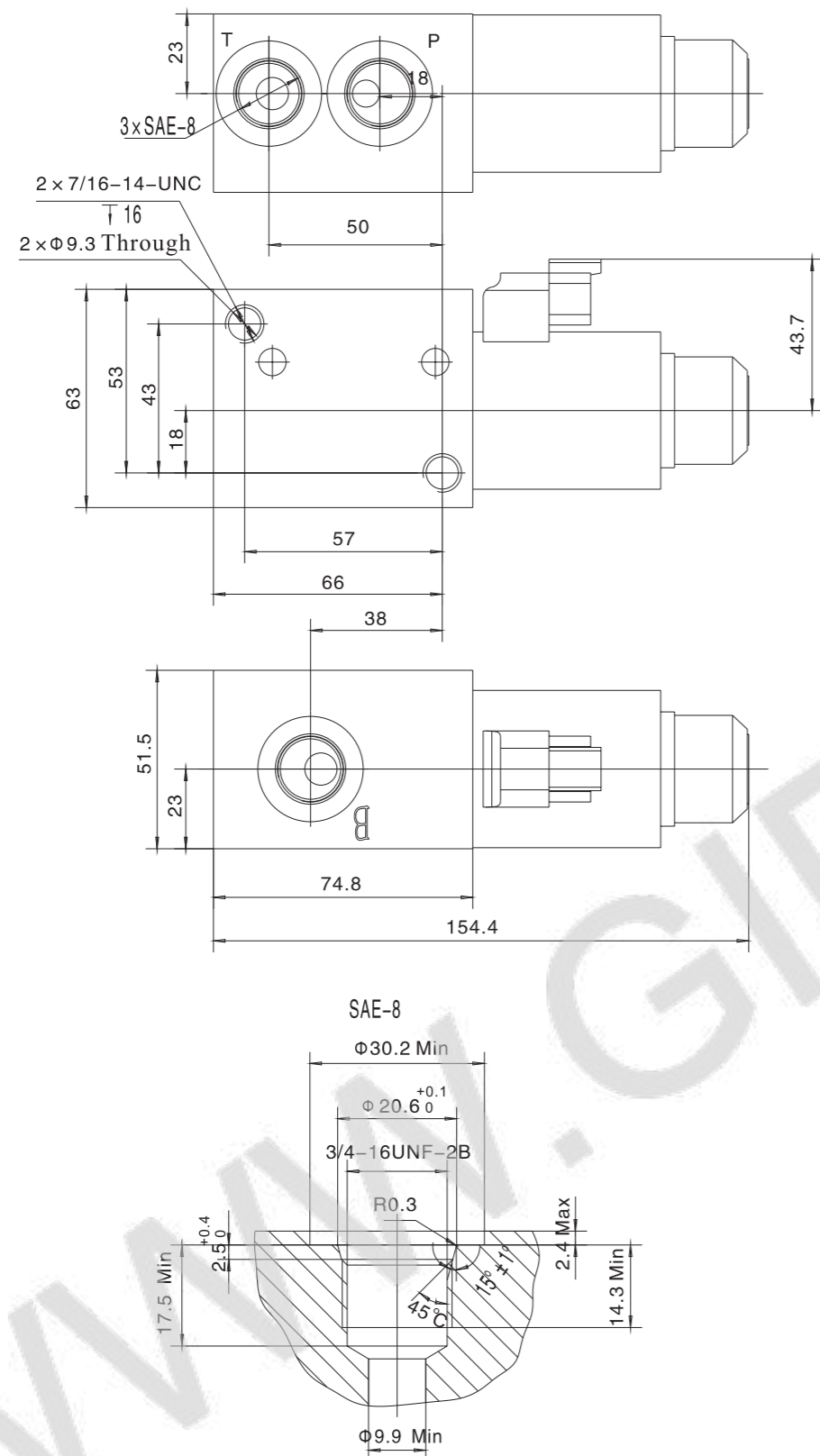

A.8.3

2-position 2-way/3-way Pressure Compensated Proportional Flow Control Valve

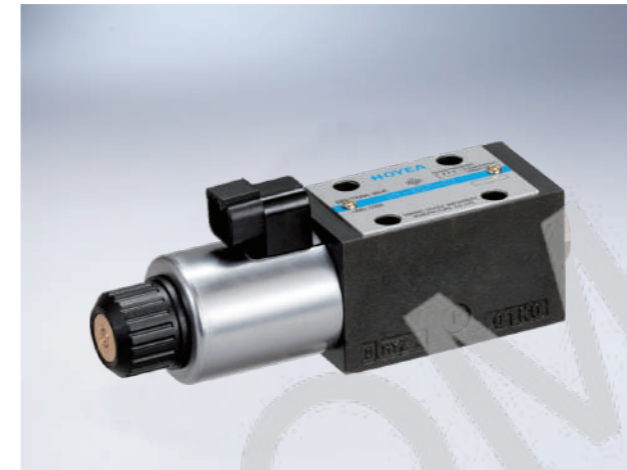

It's directly driven by proportional solenoid, convert input signal into flow output signal in proportion. Flow regulation is not affected by pressure loading. 2-way valve has pressure compensated function, and 3-way has pressure compensated, sequence priority, as well as unloading function

A.9.1

Technical parameter (please consult factory if your application is out of below range)

Model	HYXQP-02	
Mounting	Free, recommended for horizontal installing	
Working temperature	(°C)	-20~+70
Weight	(kg)	1.7

Hydraulic parameter

Max working pressure	(MPa)	25
Max flow rate	(L/min)	32
Working fluid	Mineral hydraulic oil, phosphate	
Fluid temp range	(°C)	-20~+75
Viscosity range	20~380	
Hysteresis	%	≤5
Repeatability	%	≤1
Sensibility	%	≤1
Minimum fluid cleanliness	Maximum permissible degree of pressure fluid contamination to NAS 1638 to class 9 Recommended filter β ₁₀ ≥75 .	

Electric parameter

Voltage type	Direct current	
Solenoid I-max	(A)	1.76
Coil resistance at 25°C	(Ω)	4
ED	(%)	100
Max coil temp	(°C)	Attainable 150
Electrical connection	Deutsch DT04-2P	
IP class	Ip65	

2-position 2-way/3-way Pressure Compensated Proportional Flow Control Valve

Ordering code

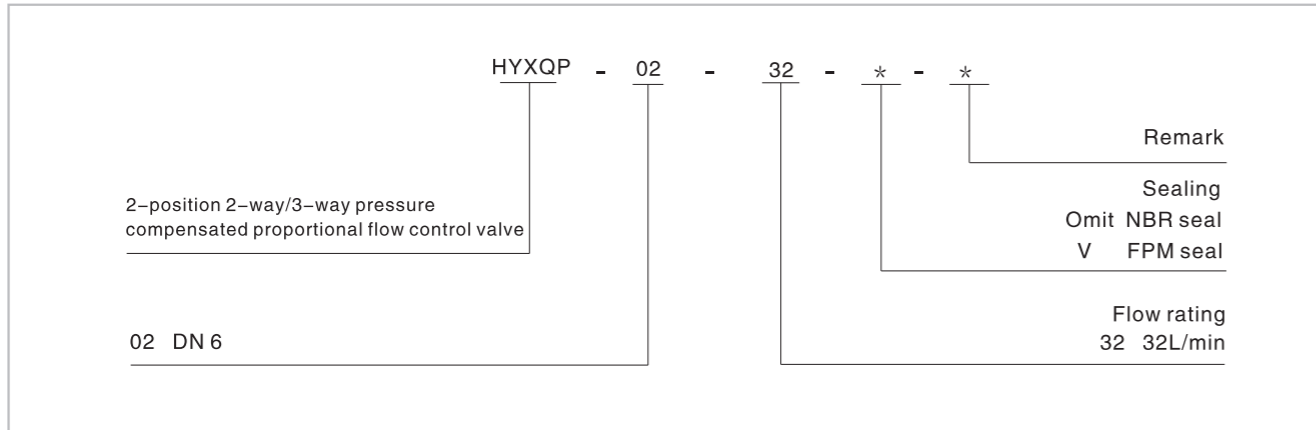

Hydraulic symbol

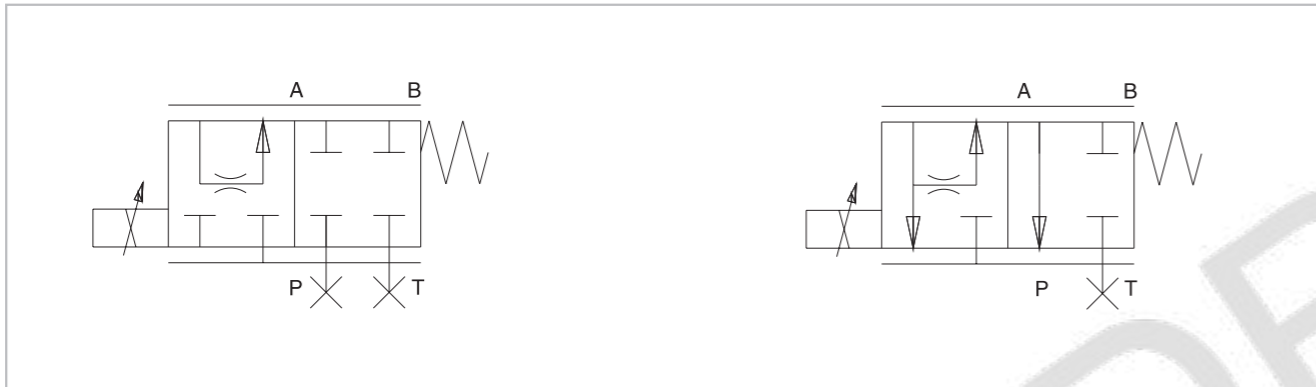

Performance curve

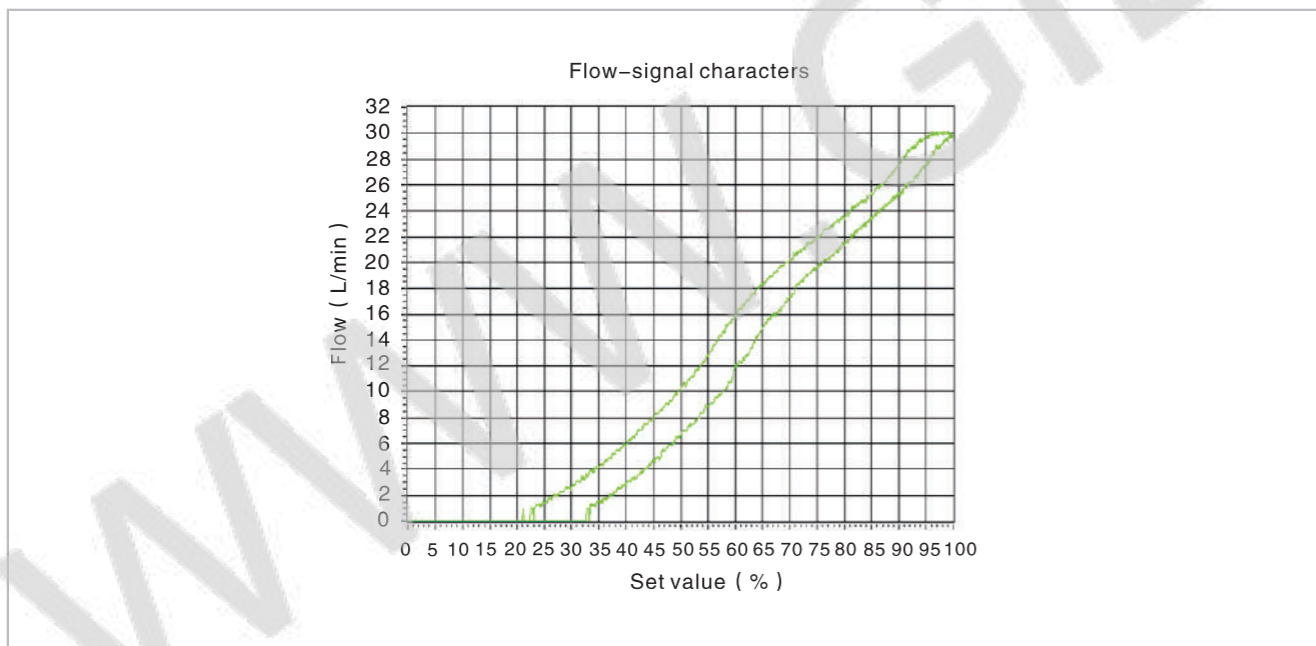

2-position 2-way/3-way Pressure Compensated Proportional Flow Control Valve

External dimension and mounting

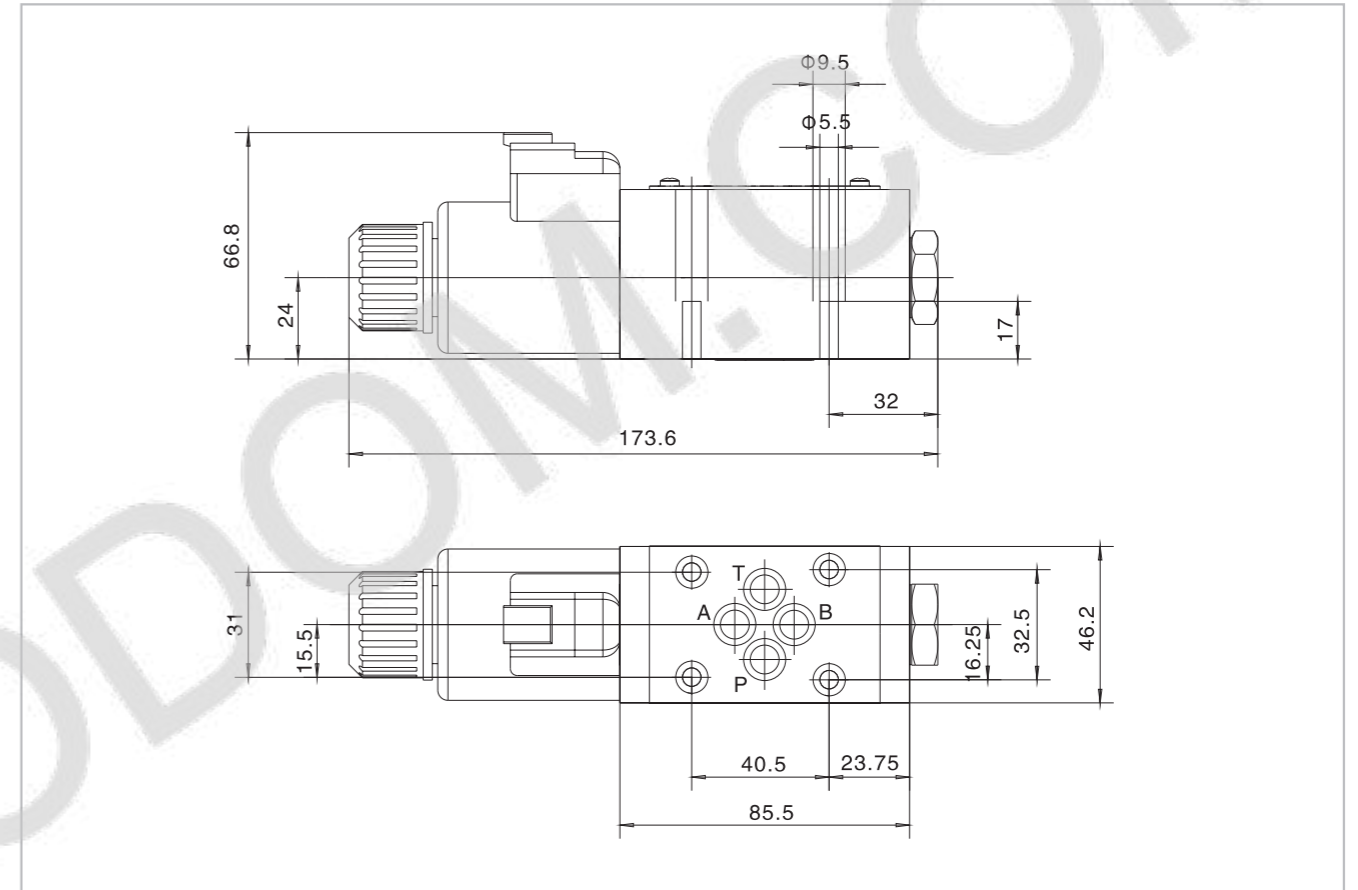

Sub-plate mounting

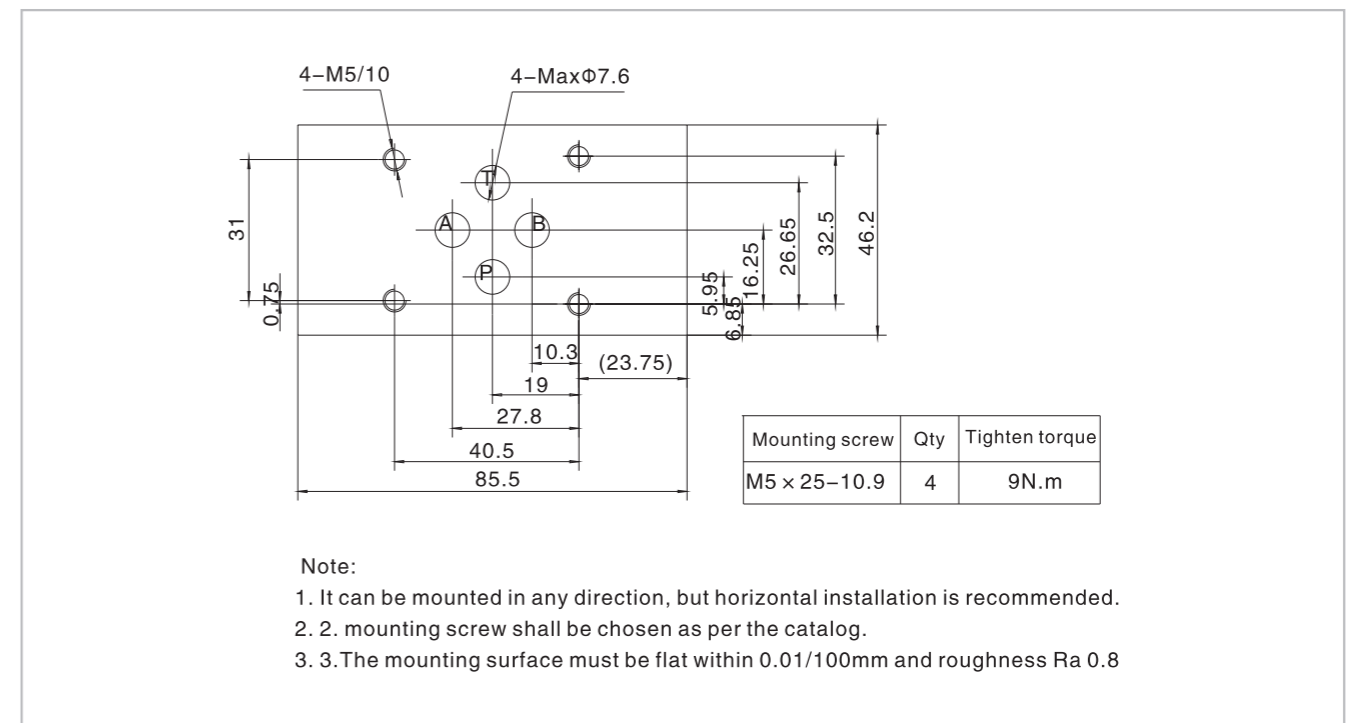

HOYEA

Pressure Control Valves Series



WWW.GIDRODOM.COM

Relief Valve

Technical specification

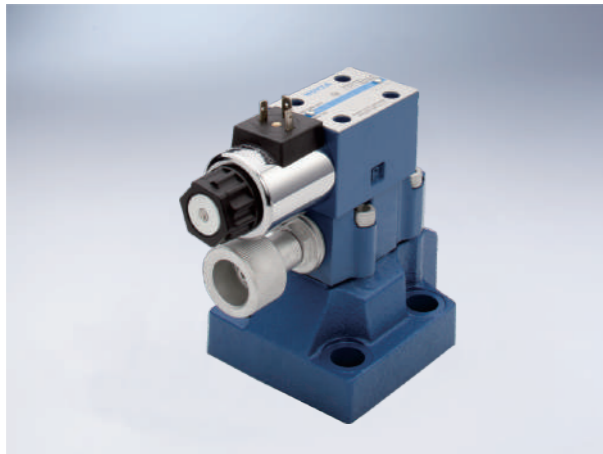

Specification	03		06		10
	10	15	20	25	30
Max. Flow (L/min)	250	500	500	500	650
Max. working pressure (MPa)	35				
Working fluid	Mineral oil; phosphate-ester				
Fluid temp. (°C)	-20~70				
Viscosity (mm ² /s)	12~380				
Working press (MPa)	5	10	20	31.5	35
Cleanliness	The maximum allowable cleanliness of the oil should be according to 9th degree of Standard NAS1638. It is suggested that the minimum filter rating should be β 10 ≥ 75.				

The relief valve is a pressure control valve. It maintains constant pressure at inlet by discharging excess fluid in the system. Solenoids relief valve is a combination of electromagnetic directional valve and pilot-operated pressure relief valve, it is used to control or unload multi-stage pressure in hydraulic system.

Model description

Relief valve Y * * - * * - * * - * * / * * * * / * * * 5X *

Omit without solenoids directional valve
W With solenoids directional valve

Omit Pilot operated valve
C Pilot operated without main cartridge (not marked diameter)
Pilot operated with main cartridge (marked diameter)

Subplate	Pipeline	DN	Screw thread connector
03	10	10	G1/2" or M22x1.5
	15	15	G3/4" or M27x2
06	20	20	G1" or M33x2
	25	25	G1 1/4" or M42x2
10	30	30	G1 1/2" or M48x2

Omit Subplate connection
G Pipe type connection-G Scrow
G2 Pipe type connection-M Scrow

Working pressure
5 to 5MPa
10 to 10MPa
20 to 20MPa
31.5 to 31.5MPa
35 to 35MPa

A Always close¹⁾
B Always open

1 Rotary knob
2 Sleeve with hehagon and protective cap

Remarks
Serial number
Seal material
Omit NBR Seals
V FPM Seals
Pilot operated drainage port thread
Omit G1/4"
2 M14X1.5
Omit No damping²⁾
08 Φ0.8 Damping
10 Φ1.0 Damping
12 Φ1.2 Damping
Omit without push rod emergency³⁾
N9 with concealed push rod emergency
Z5L Square connector with light⁴⁾
Working voltage⁵⁾
D12 DC12V
D24 DC24V
A110 AC110V
A220 AC220V
B110 (B110V Rectified)
B220 (B220V Rectified)
Omit Standard Type⁶⁾
U minimum setting pressure is lower type
Omit Intl cntrl intl disch
X Extl cntrl intl disch
Y Intl cntrl extl disch
XY Extl cntrl extl disch

Relief Valve

Notice explanation

- Item 1),2),3),4),5) is used in YW solenoid relief valves
- Item 2) damping is fixed at port B of solenoid directional valves
- 6) Type U characteristic refer to the curve

Code symbol

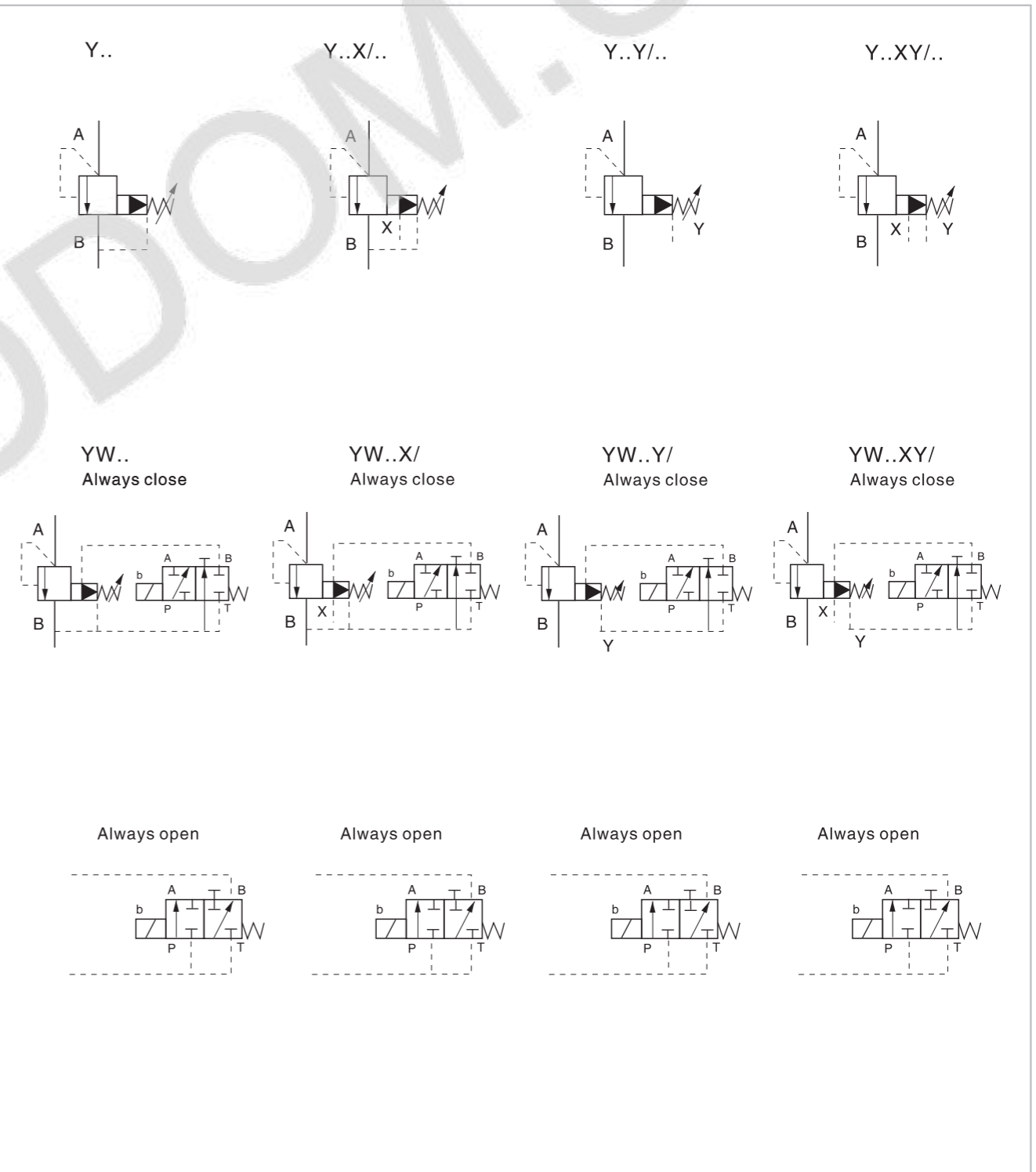

Relief Valve

Performance curve (Measured at $v=41\text{mm}^2/\text{s}$ and $t=50^\circ\text{C}$)

- 1) The characteristic curves were measured with external, pressureless, pilot oil drain.
- 2) In the case of internal pilot oil drain, the inlet pressure increases by the outlet pressure in port T.

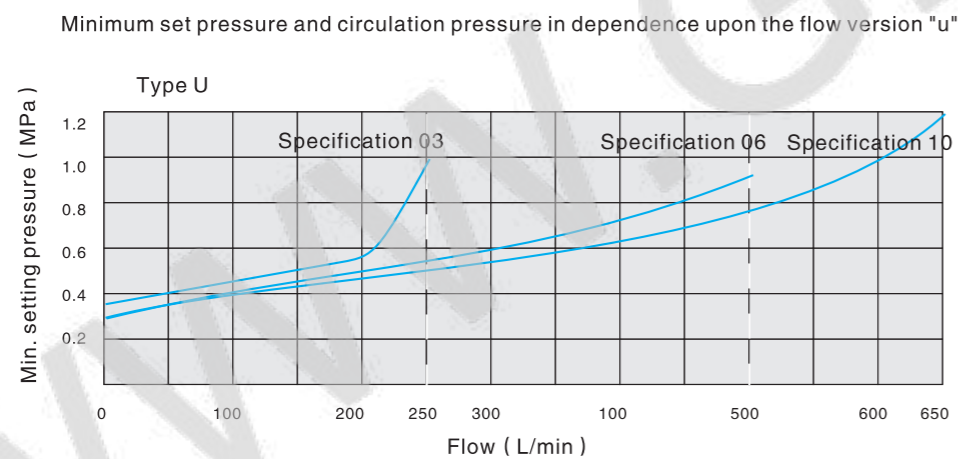
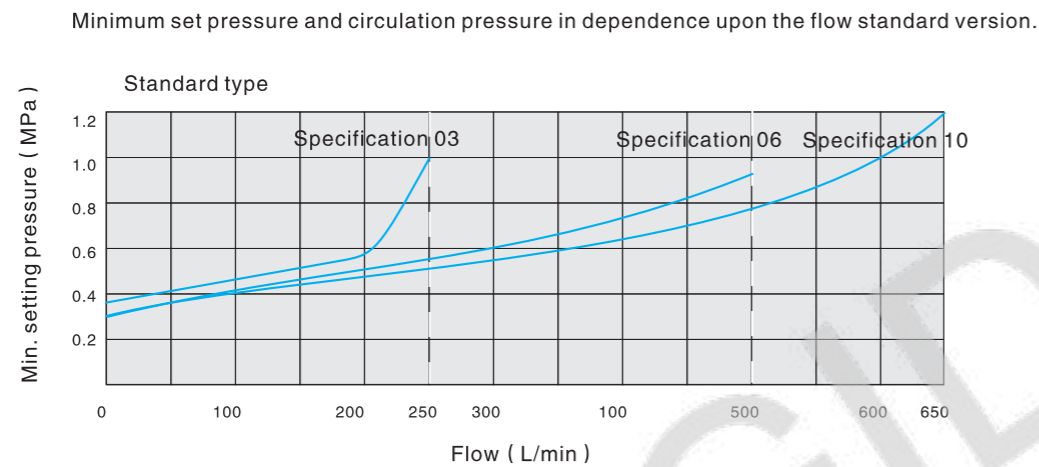
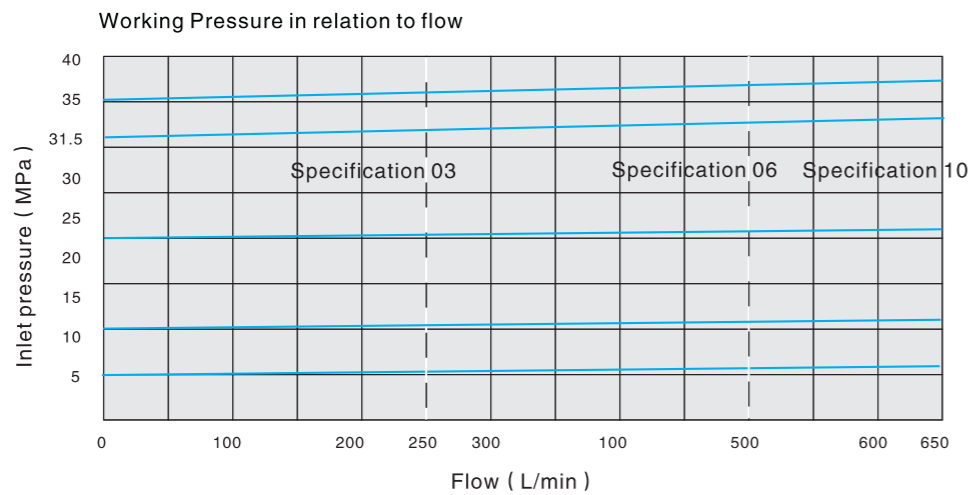

The characteristic curves are valid for outlet pressure B:0 over the entire flow range.

Relief Valve

External dimensions

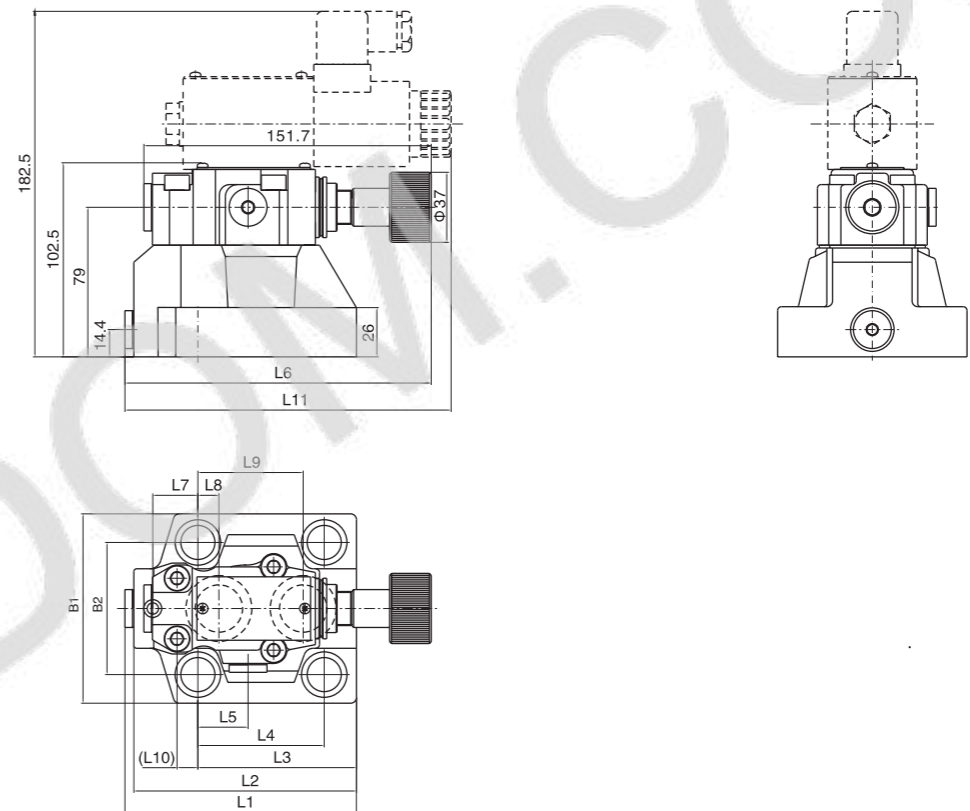

Subplate mounting size

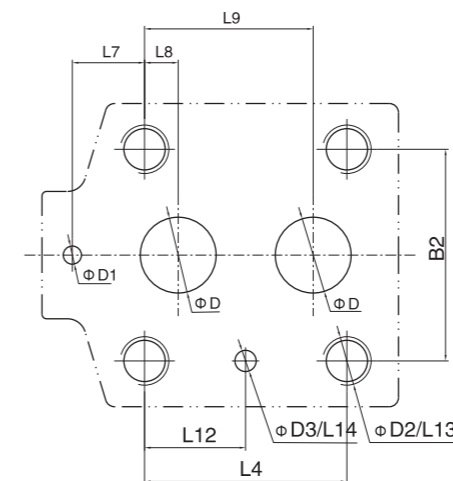

Specification	Mounting screw	Tighten torque
Y/YW-03	M12x45-10.9	130Nm
Y/YW-06	M16x50-10.9	310Nm
Y/YW-10	M18x50-10.9	430Nm

Notice: The surface, connecting with the valve, should be Ra0.8 roughness, and 0.01/100mm flatness.

Specification	B1	B2	L1	L2	L3	L4	L5	L6	L7	L8	L9	L10	L11	L12	L13	L14	D	D1	D2	D3
Y/YW-03	78	54	98.5	91.5	67	54	23.5	149.3	0	22.1	47.5	14	159.7	22.1	20	5	12	6	M12	7
Y/YW-06	100	69.8	122.2	117.5	83.7	66.7	26.5	161.8	23.8	11.1	55.6	11	172.2	33.3	25	6	25	6	M16	7
Y/YW-10	115	82.6	154.5	149.5	106.9	88.9	28.1	172.5	31.8	12.7	76.2	9.4	182.9	44.4	30	6	32	6	M18	7

Sequence Valve

Technical specification



Specification	03	06	10
Max. working pressure (MPa)	31.5		
Max. Flow (L/min)	250	500	600
Working fluid	Mineral oil;phosphate-ester		
Fluid temp. (°C)	-20~70		
Viscosity (mm ² /s)	12~380		
Working press (MPa)	5	10	20 31.5
Cleanliness	The maximum allowable cleanliness of the oil should be according to 9th degree of Standard NAS1638. It is suggested that the minimum filter rating should be β 10≥75.		

YS pilot-operated sequence valve is used to control action sequence of actuators in hydraulic systems so as to achieve automatic control. By changing the control mode, it can serve as back pressure valve, unload valve, bypass valve and sequence valve. In addition, an internal supply internal discharge or an external supply internal discharge sequence valve can also be used as a balance valve if it includes a check valve.

Model description

YS * - * - * * - * * / * * 5X *

Sequence valve

Pilot operated valve
Omit Pilot operated without main cartridge (not marked diameter)
C Pilot operated with main cartridge (marked diameter)

Specification
03 DN10
06 DN20
10 DN30

Working press
5 to 5MPa
10 to 10MPa
20 to 20MPa
31.5 to 31.5MPa
35 to 35MPa

Omit Without check valve
D With check valve

Remarks

Serial number

Seal material
Omit NBR Seals
V FPM Seals

Pilot operated drainage port thread
Omit G1/4"
M M14X1.5

Omit Intl cntrl intl disch
X Extl cntrl intl disch
Y Intl cntrl extl disch
XY Extl cntrl extl disch

1 Rotary knob
2 Sleeve with hexagon and protective cap

Sequence Valve

Code symbol

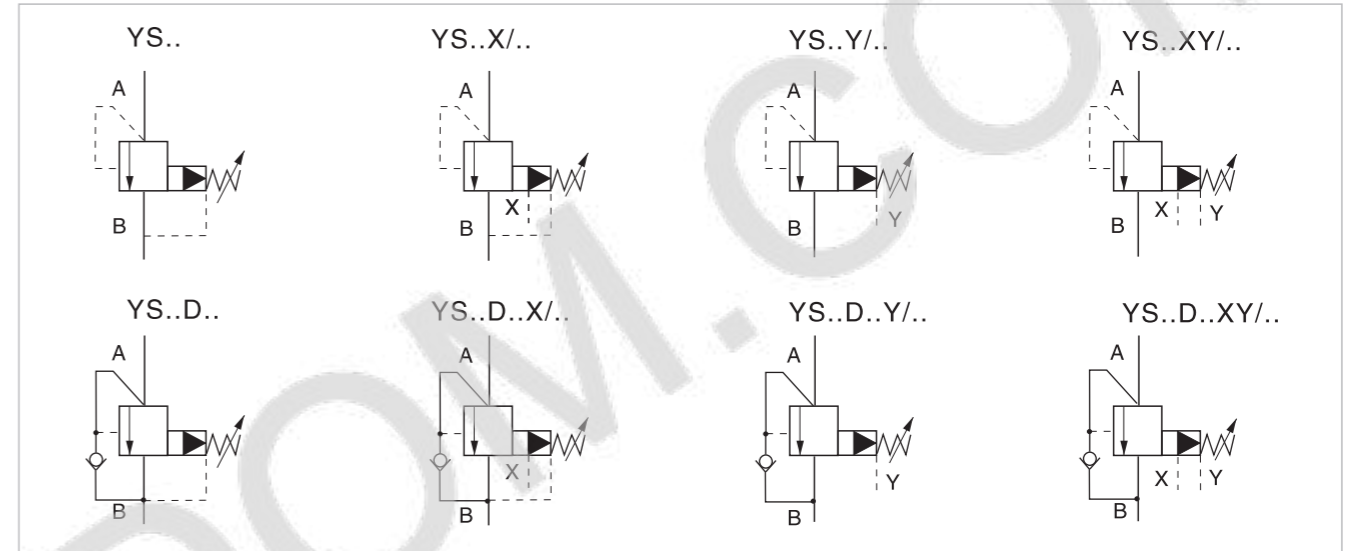

Performance curve (Measured at: Test under $v=41\text{mm}^2/\text{s}$ and $t=50^\circ\text{C}$)

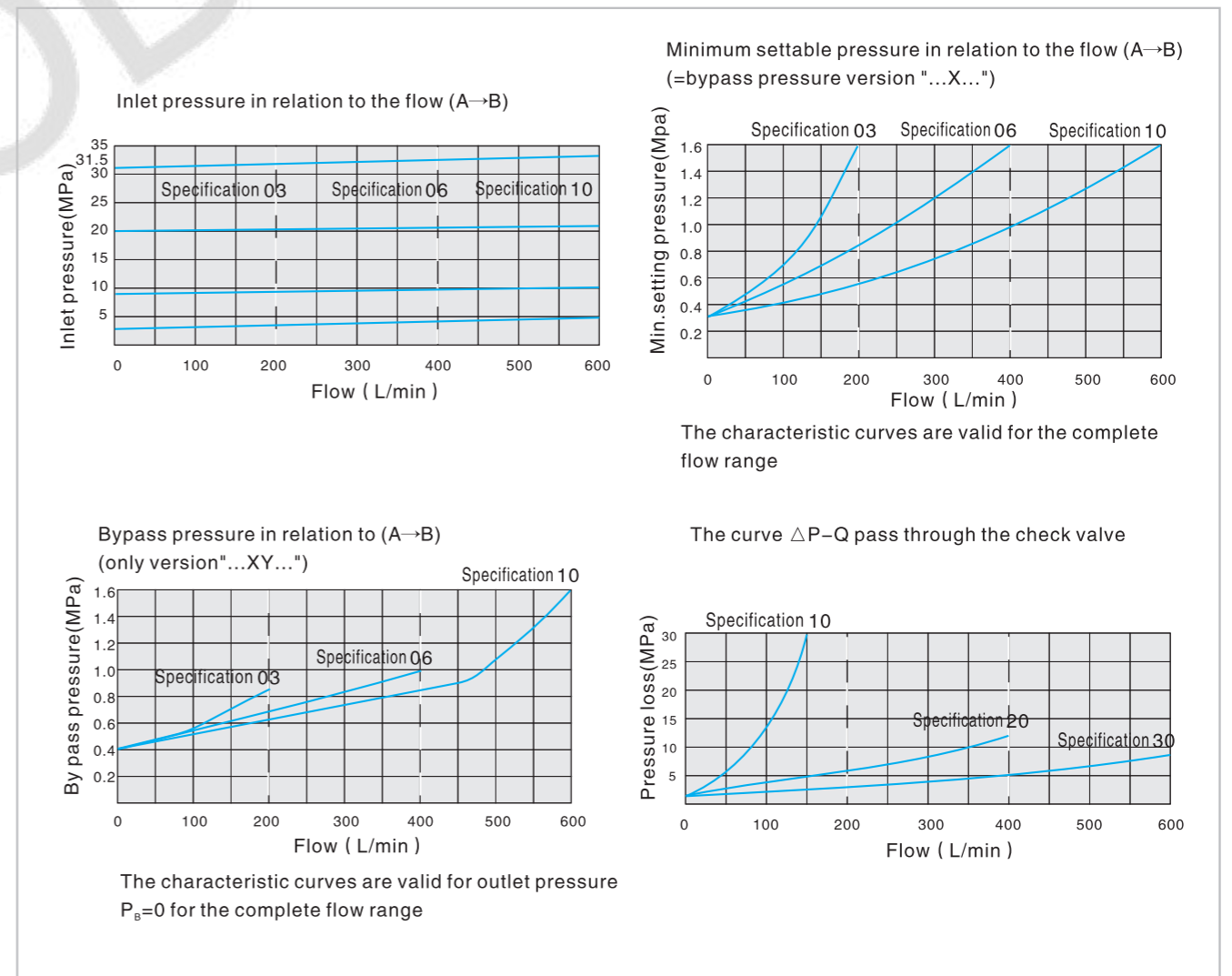

Sequence Valve

External dimensions

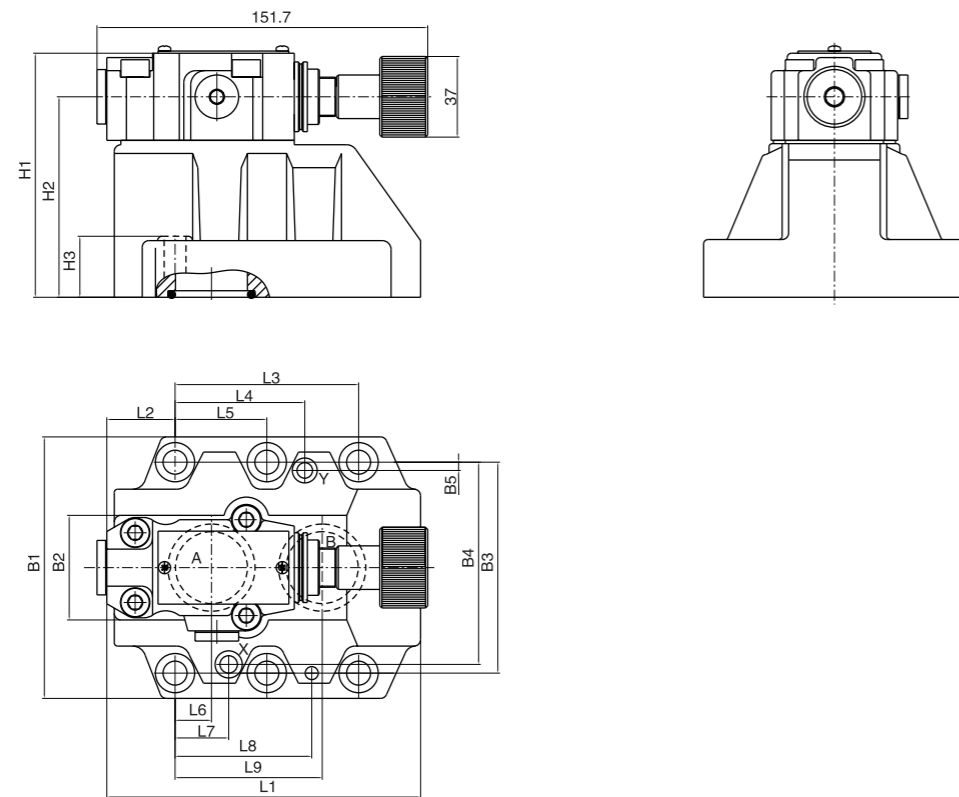

Subplate mounting size

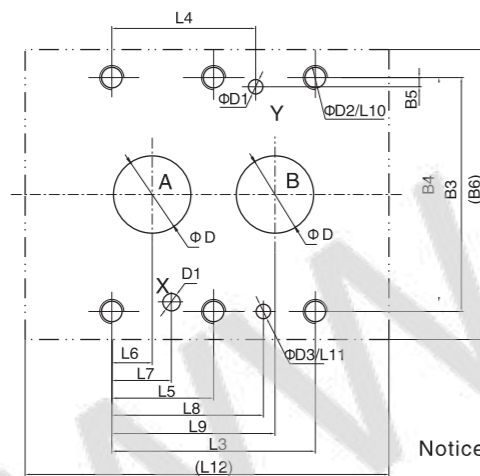

Notice: The surface, connecting with the valve, should be Ra0.8 roughness, and 0.01/100mm flatness.

Specification	Mounting screw	Tighten torque
YS-03	4-M10x50-10.9	75Nm
YS-06	4-M10x60-10.9	75Nm
YS-10	6-M10x70-10.9	75Nm

Model	L1	L2	L3	L4	L5	L6	L7	L8	L9	L10	L11	L12	B1	B2	B3	B4	B5	B6	H1	H2	H3	D	D1	D2	D3
YS-03	96	35.5	42.9	21.5	-	7.2	21.5	31.5	35.8	23	6	98	85	80	66.7	58.8	7.9	87	112	92	28	12	6	M10	7
YS-06	116	37.5	60.3	39.7	-	11.1	20.6	44.5	49.2	24	6	118	102	59.5	79.4	73	6.4	104	122	102	38	25	6	M10	7
YS-10	145	33	84.2	59.5	42.1	16.7	24.6	62.7	67.5	25	6	147	120	76	96.8	92.8	3.8	149	130	110	46	32	6	M10	7

Unloading Relief Valve

Technical specification



Specification	03	06	10	
Max. working pressure (MPa)	31.5			
Max. Flow (L/min)	10%	40	80	120
	7%	60	120	240
Working fluid	Mineral oil; phosphate-ester			
Fluid temp. (°C)	-20~70			
Viscosity (mm ² /s)	12~380			
Working press (MPa)	5	10	20	31.5
	Cleanliness			
	The maximum allowable cleanliness of the oil should be according to 9th degree of Standard NAS1638. It is suggested that the minimum filter rating should be β 10≥75.			

YX/YXW valve is a pilot-operated unloading valve. Its function is to switch two situations in hydraulic system, by adjusting handle to set the working pressure or unloading pressure. Pump will be unloading automatically by controlling electrical magnetic.

Model description

YX * * - * - * * - * * / * * * * / * / * * 5X *

Remarks
Unloading Relief Valve
Omit without solenoids directional valve
W With solenoids directional valve
Pilot operated valve
Omit Pilot operated without main cartridge (not marked diameter)
C Pilot operated with main cartridge (marked diameter)
Specification
03 DN10
06 DN20
10 DN30
Working pressure
5 to 5MPa
10 to 10MPa
20 to 20MPa
31.5 to 31.5MPa
A Always closed ¹⁾
B Always open
1 Rotary knob
2 Sleeve with hexagon and protective cap
Omit Intl cntrl intl disch
Y Intl cntrl extl disch
Serial number
Seal material
Omit NBR Seals
V FPM Seals
Pilot operated drainage port thread
Omit G1/4"
M M14X1.5
Omit No damping ²⁾
08 Φ0.8 Damping
10 Φ1.0 Damping
12 Φ1.2 Damping
Omit without push rod emergency ³⁾
N9 with concealed push rod emergency
Z5L Square connector with light ⁴⁾
Working voltage ⁵⁾
D12 DC12V
D24 DC24V
A110 AC110V
A220 AC220V
B110 (A110V Rectified)
B220 (A220V Rectified)
Switching differential pressure (P→A)
10 on average
17 on average

Explanation: 1. 1),2),3),4),5) is used in YXW solenoids relief valves
2. 2) damping is fixed at the B oil port of the solenoids directional valves

Unloading Relief Valve

Code symbol

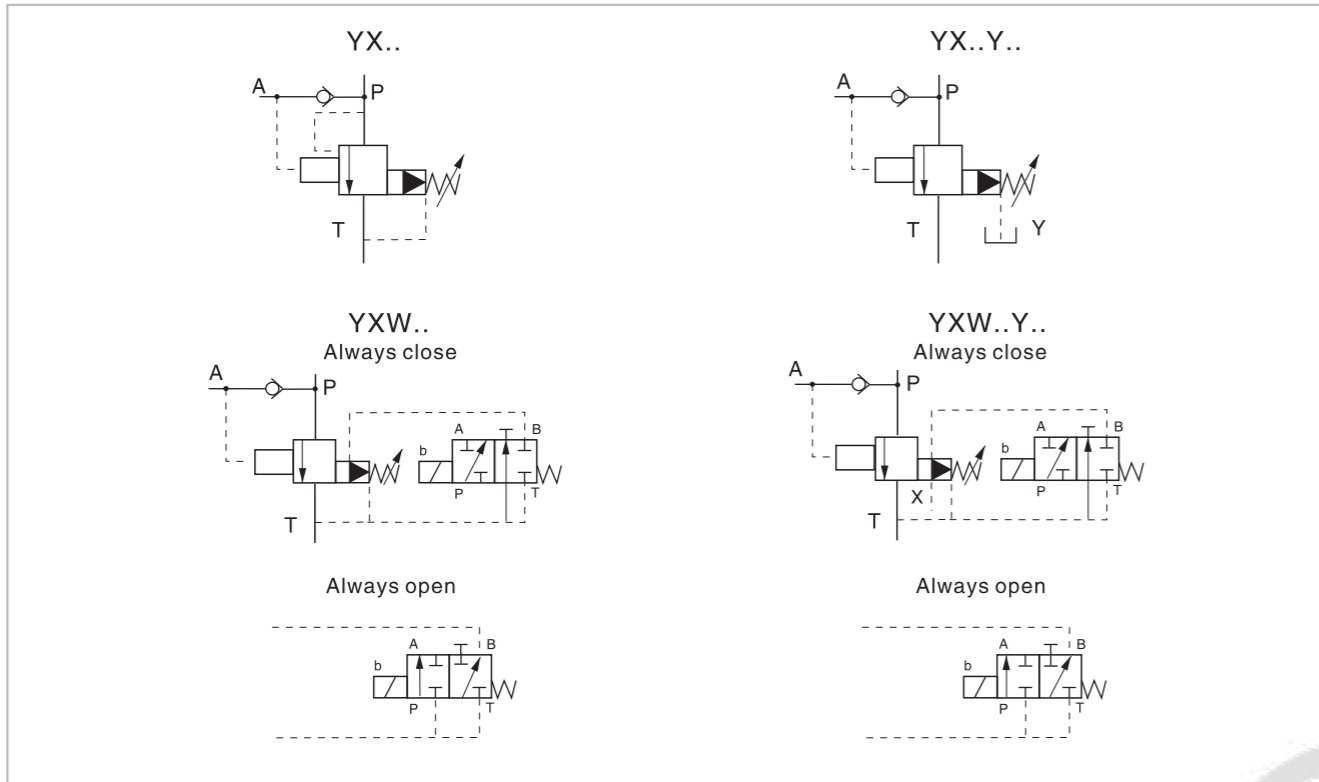

B.3.2

Performance curve (Measured at $v=41\text{mm}^2/\text{s}$ and $t=50^\circ\text{C}$)

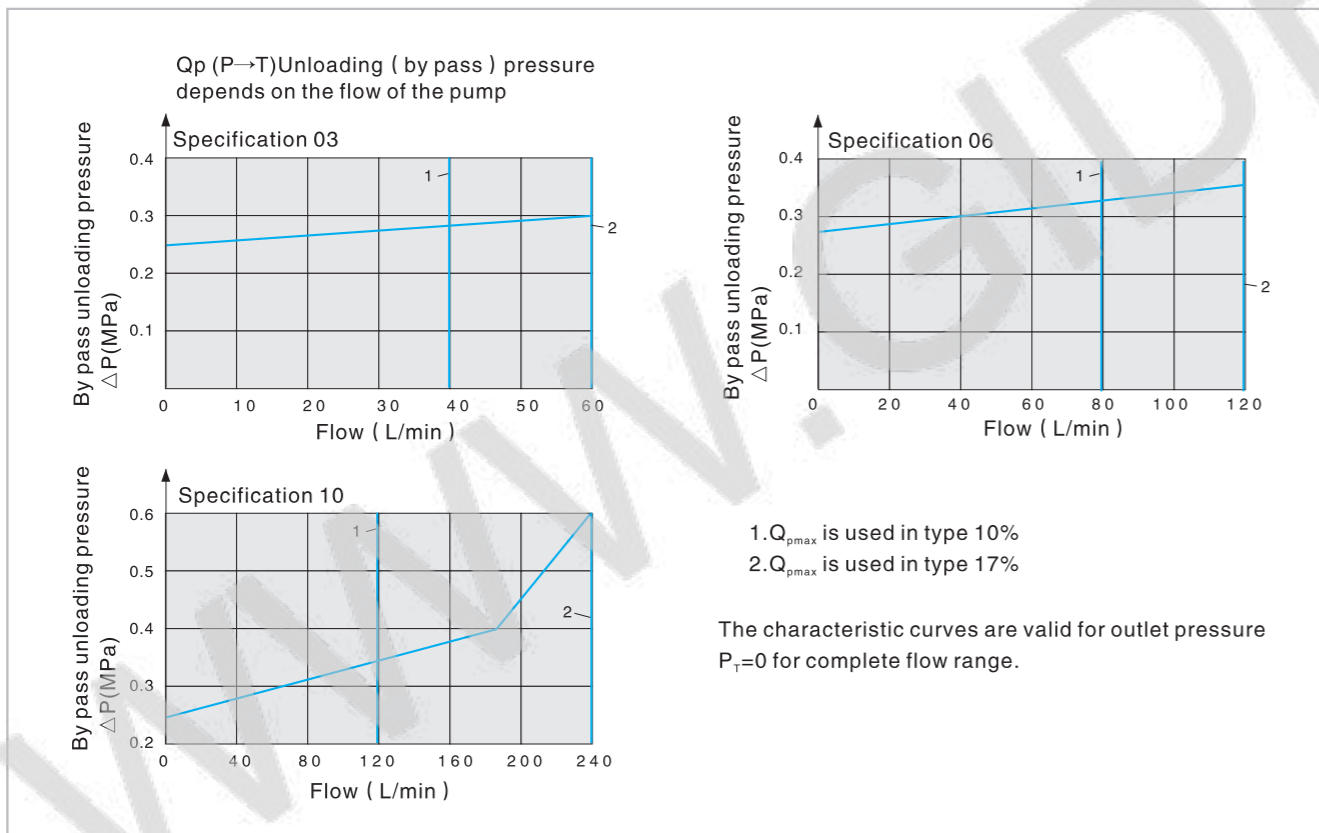

B.3.2

Unloading Relief Valve

Performance curve (Measured at $v=41\text{mm}^2/\text{s}$ and $t=50^\circ\text{C}$)

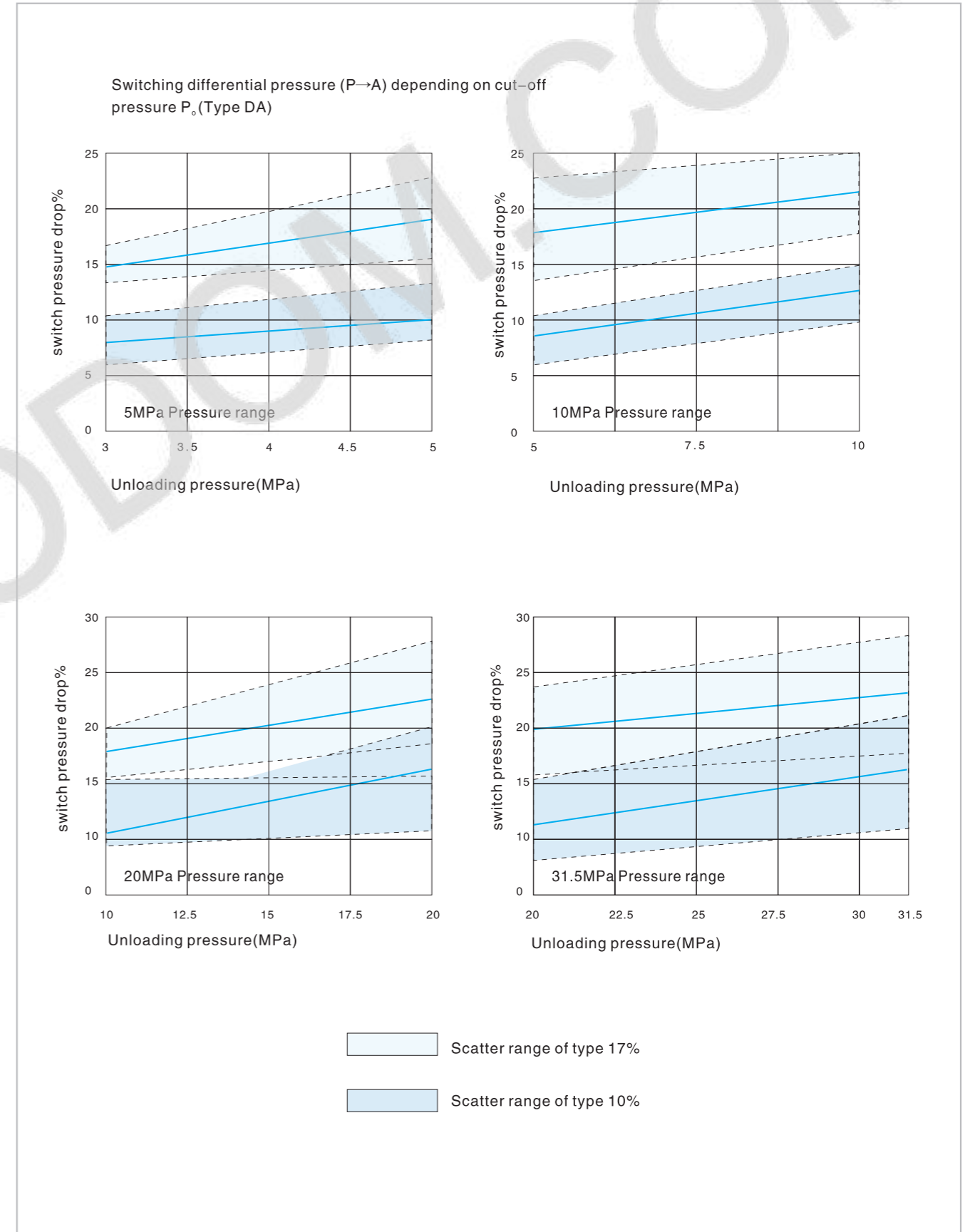

B.3.3

B.3.3

Unloading Relief Valve

03 External dimensions

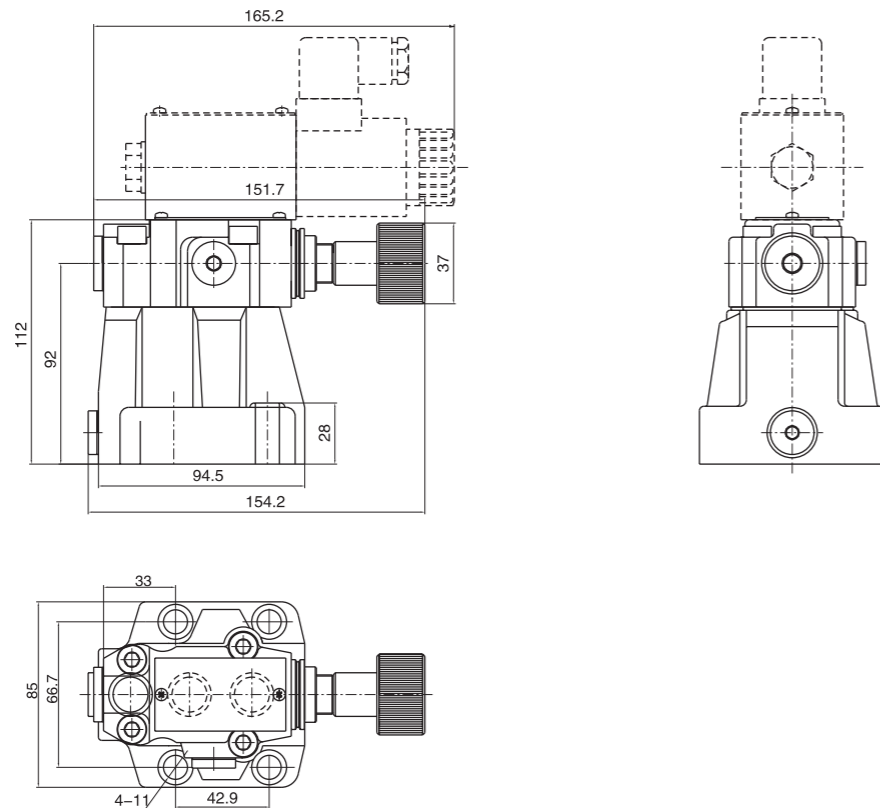

B.3.4

Unloading Relief Valve

06、10 External dimensions

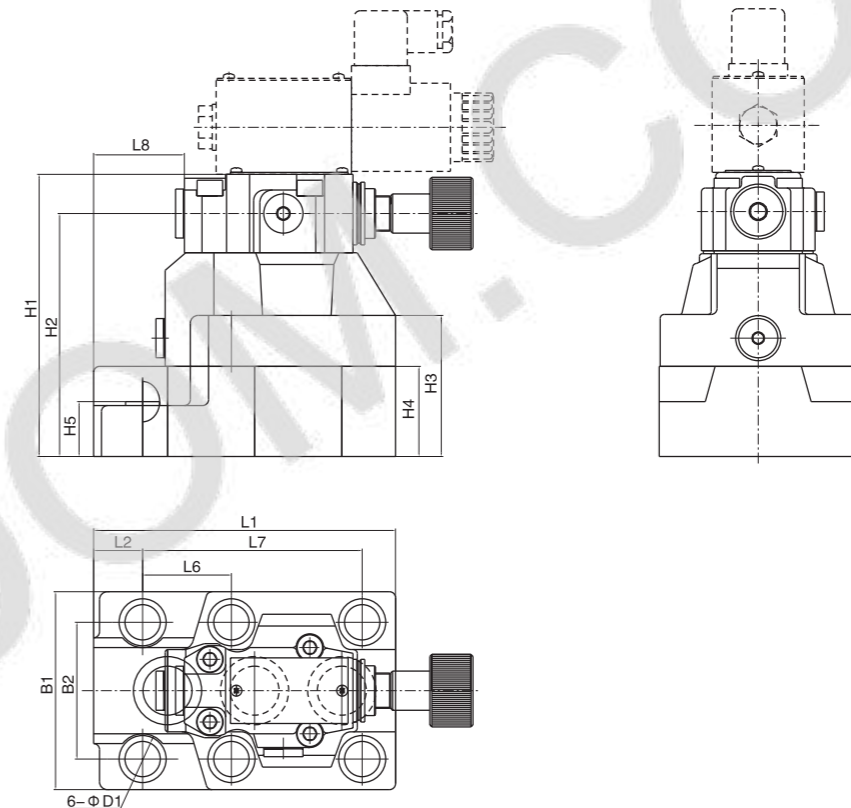

B.3.5

03 Subplate mounting size

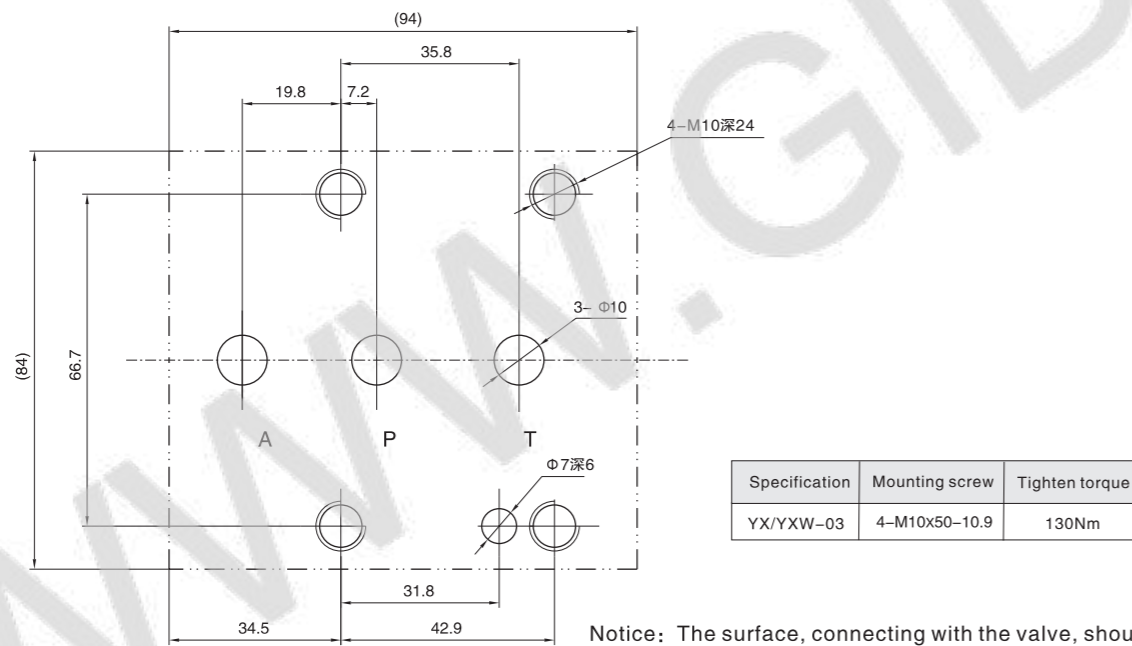

Notice: The surface, connecting with the valve, should be Ra0.8 roughness, and 0.01/100mm flatness.

06、10 Subplate mounting size

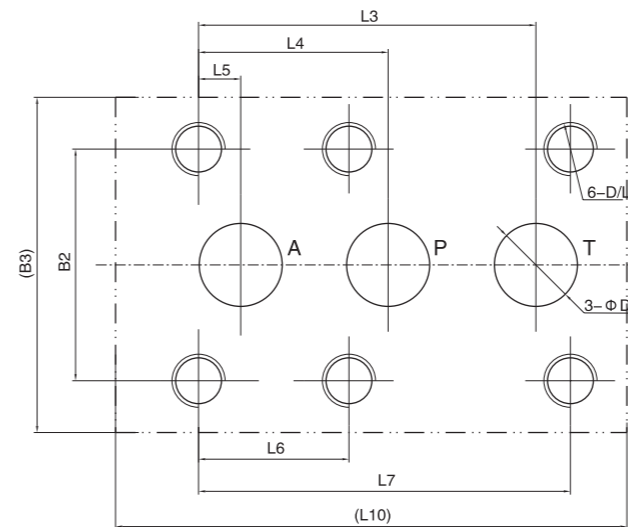

Specification	Mounting screw	Tighten torque
YX/YXW-06	4-M16x100-10.9 2-M16x60-10.9	310Nm
YX/YXW-10	4-M18x120-10.9 2-M18x80-10.9	430Nm

Notice: The surface, connecting with the valve, should be Ra0.8 roughness, and 0.01/100mm flatness.

Specification	L1	L2	L3	L4	L5	L6	L7	L8	L9	L10	B1	B2	B3	H1	H2	H3	H4	H5	D	D1	D2
YX/YXW-06	154	25	101.6	57.1	12.7	46	112.7	46.3	34	156	101	69.9	103	144	124	72	46	28	M16	18	25
YX/YXW-10	199	42	127	63.5	12.7	50.8	139.7	67.9	37	201	118.5	82.5	118.5	165	145	93	87	45	M18	20	32

Direct-operated Reducing Valve

Technical specification



Specification	05
Max. working pressure (MPa)	31.5
Max. Flow (L/min)	15
Working fluid	Mineral oil; phosphate-ester
Fluid temp. (°C)	-20~80
Viscosity (mm ² /s)	-2.8~500
Cleanliness	The maximum allowable cleanliness of the oil should be according to 9th degree of Standard NAS1638. It is suggested that the minimum filter rating should be $\beta 10 \geq 75$.

HYDR5DP is direct-operated reducing valve for pressure relief in minor circuit, used to reducing pressure in some circuit of the system

Model description

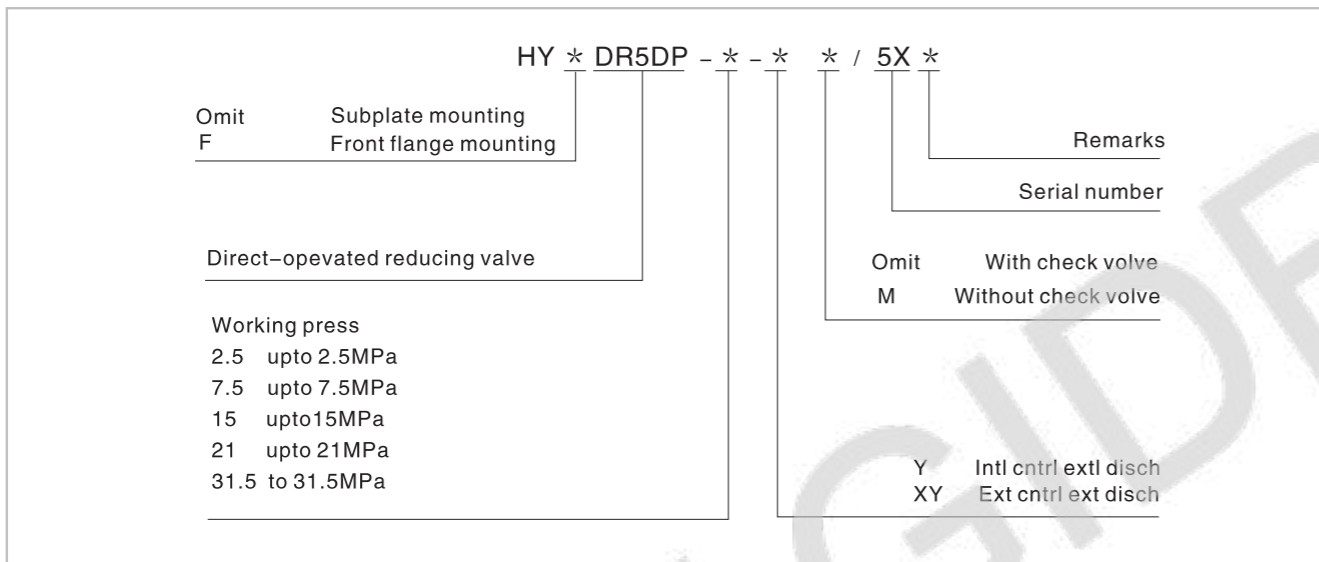

Code symbol

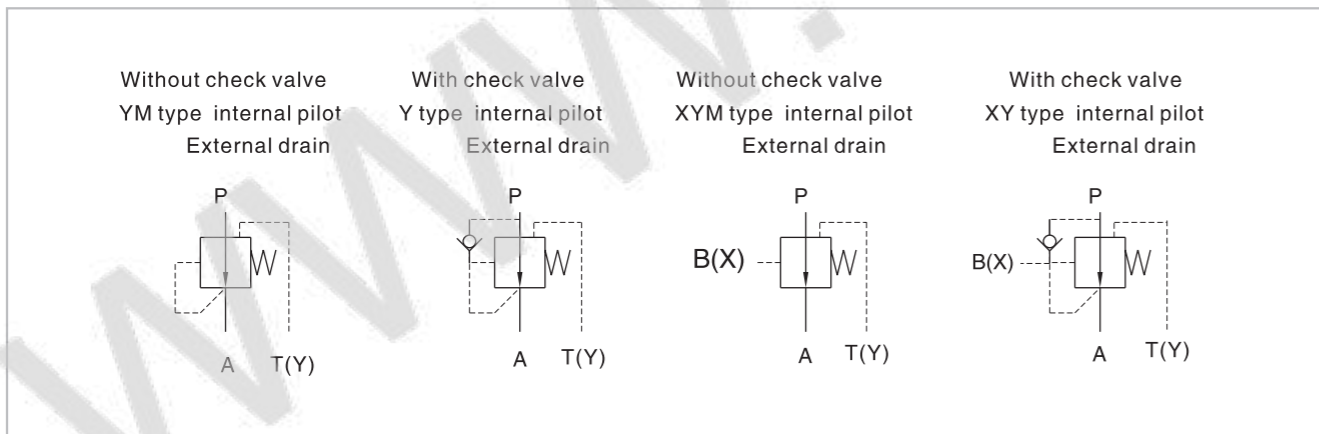

Pressure Reducing Valve

External dimensions

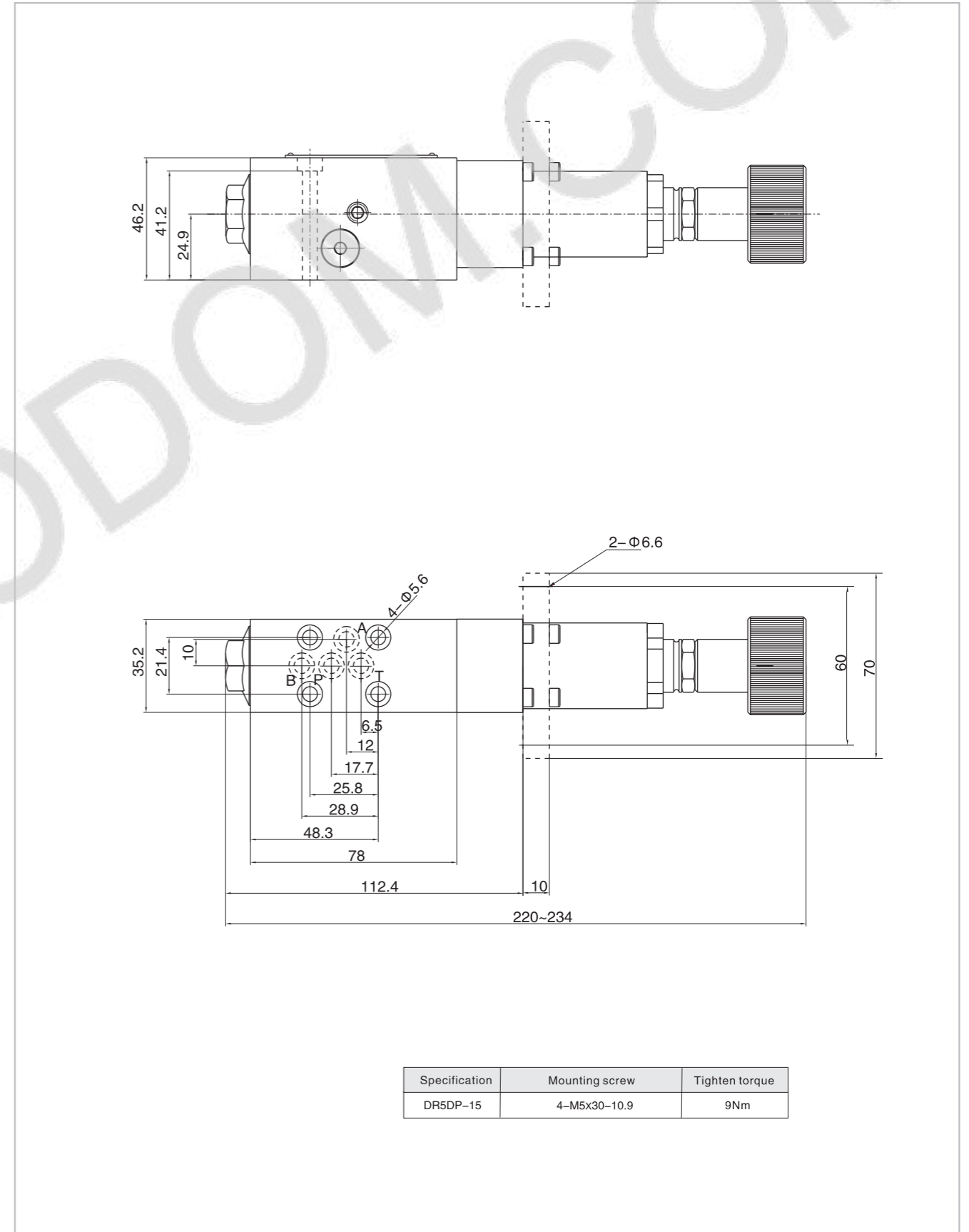

Pressure Reducing Valve

Technical specification



Specification	03	06
Max. working pressure (MPa)	31.5	
Max. Flow (L/min)	150	300
Working fluid	Mineral oil; phosphate-ester	
Fluid temp. (°C)	-20~70	
Viscosity (mm ² /s)	12~380	
Working pressure (MPa)	5	10 20 31.5
Cleanliness	The maximum allowable cleanliness of the oil should be according to 9th degree of Standard NAS1638. It is suggested that the minimum filter rating should be $\beta_{10} \geq 75$.	

The YJ pilot-operated reducing valve is controlled by the pilot and mainly used to reduce the pressure of a certain loop in the hydraulic system. It is suitable for hydraulic systems with a large flow rate.

Model description

YJ * - * - * * - * Y / * * 5X *

<p>Pressure Reducing Valve</p> <p>Pilot operated valve Omit Pilot operated without main cartridge (not marked diameter) C Pilot operated with main cartridge (marked diameter)</p> <p>Specification 03 DN10 06 DN20</p> <p>Omit Subplate type connection</p> <p>Working press 5 to 5MPa 10 to 10MPa 20 to 20MPa</p>	<p>Remarks</p> <p>Serial number</p> <p>Seal material Omit NBR Seals V FPM Seals</p> <p>Pilot operated drainage port thread Omit G1/4" M M14X1.5</p> <p>1 Rotary knob 2 Sleeve with hexagon and protective cap</p> <p>Omit Without check valve D With check valve</p>
---	--

Code symbol

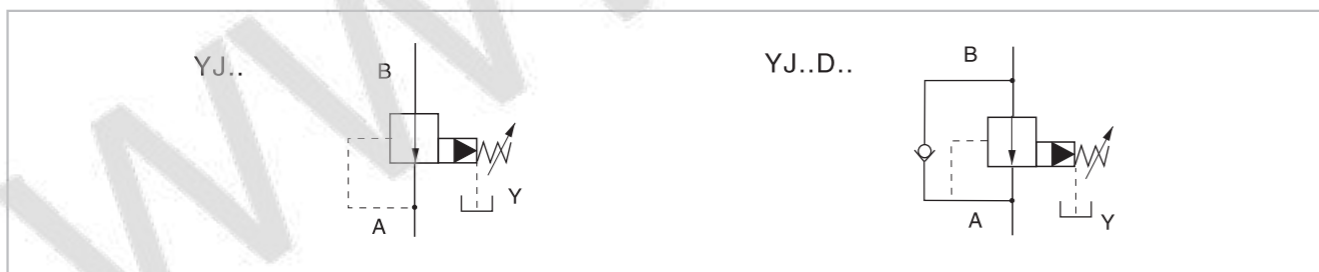

Pressure Reducing Valve

Performance curve (Test condition: Test under $\nu=41\text{mm}^2/\text{s}$ and $t=50^\circ\text{C}$)

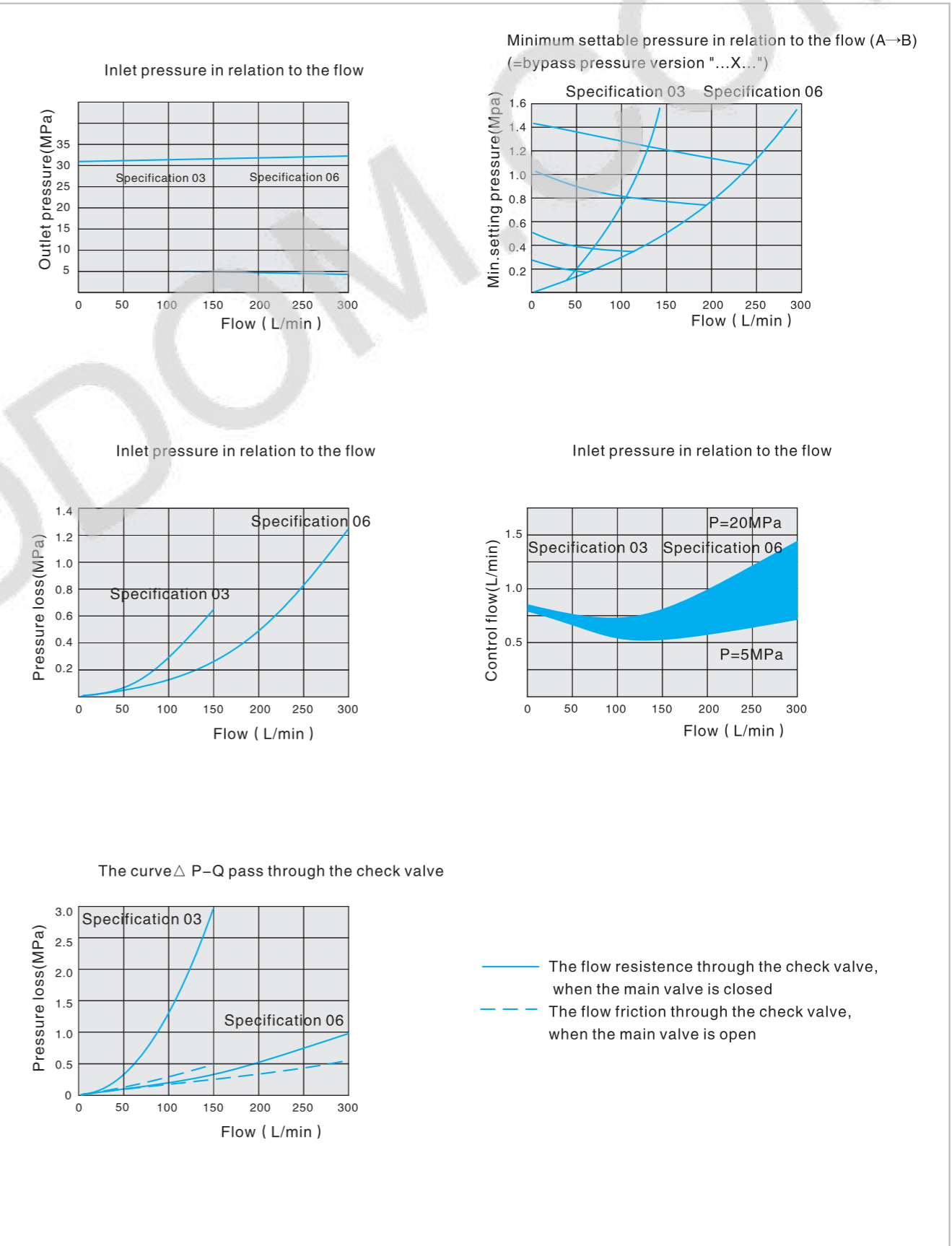

Pressure Reducing Valve

External dimensions

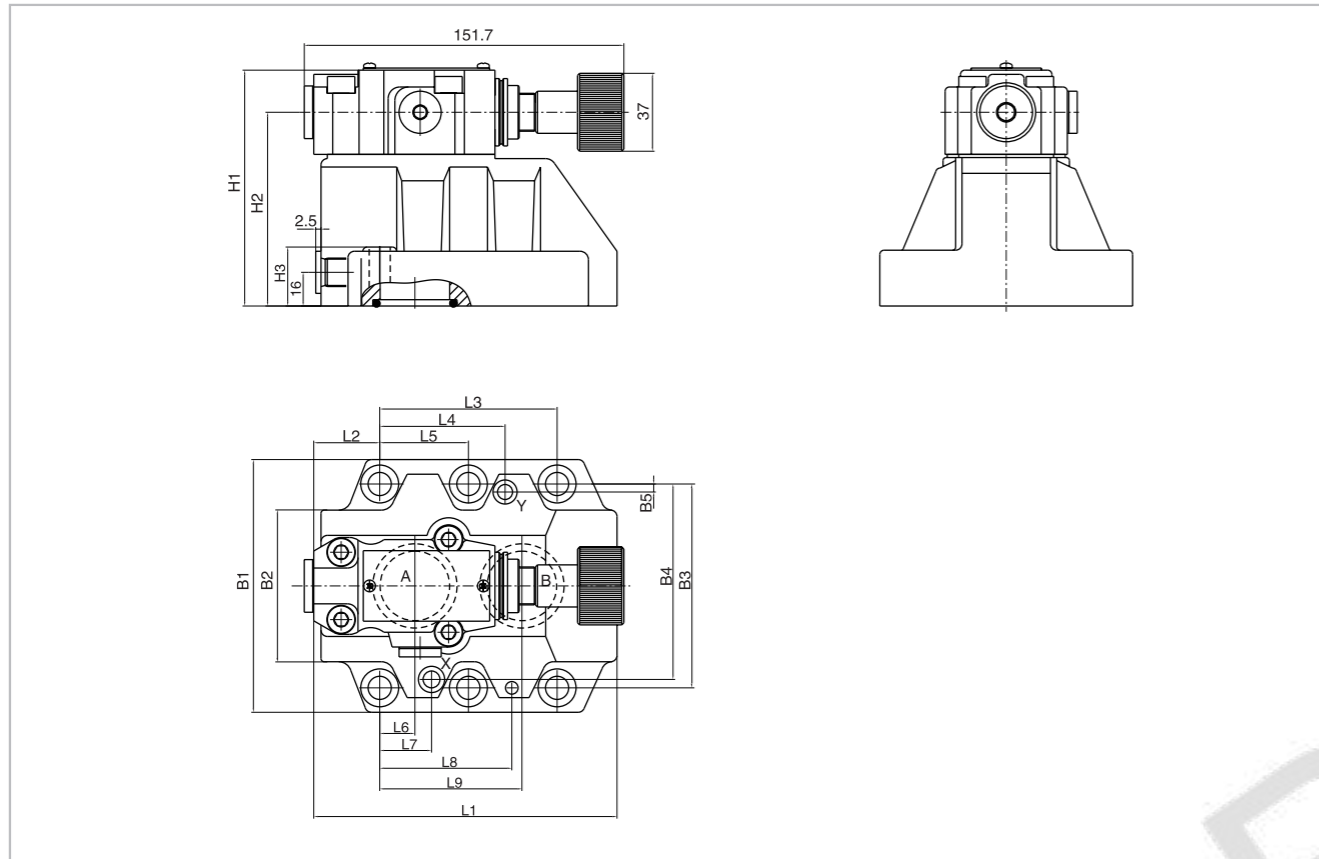

Subplate mounting size

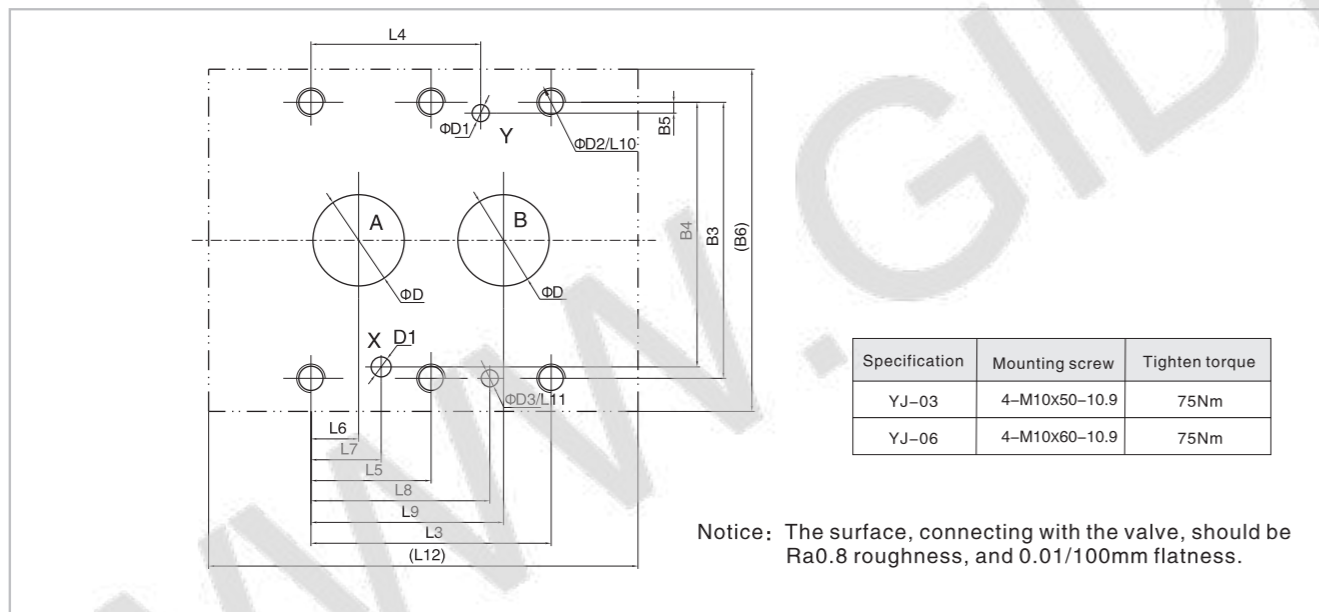

Model	L1	L2	L3	L4	L5	L6	L7	L8	L9	L10	L11	L12	B1	B2	B3	B4	B5	B6	H1	H2	H3	D	D1	D2	D3
YJ-03	96	35.5	42.9	21.5	-	7.2	21.5	31.5	35.8	23	6	98	85	50	66.7	58.8	7.9	87	112	92	28	12	6	M10	7
YJ-06	116	37.5	60.3	39.7	-	11.1	20.6	44.5	49.2	24	6	118	102	59.5	79.4	73	6.4	104	122	102	38	25	6	M10	7

Modular Relief Valve

Technical specification



Specification	02	03
Max. working pressure (MPa)	31.5	
Max. Flow (L/min)	35	70
Working fluid	Mineral oil; phosphate-ester	
Fluid temp. (°C)	-20~70	
Viscosity (mm²/s)	12~380	
Working press (MPa)	7	14 21 31.5
Cleanliness	The maximum allowable cleanliness of the oil should be according to 9th degree of Standard NAS1638. It is suggested that the minimum filter rating should be $\beta_{10} \geq 75$.	

Model description

Modular relief valve

Specification
02 DN 6
03 DN 10

P P Pipeline relief
A A Pipeline relief
B B Pipeline relief
W A B Pipeline relief

Working pressure
5 to 5MPa
10 to 10MPa
20 to 20MPa
31.5 to 31.5MPa

DY - * * - * - * / * 7X *

Remarks

Serial number

Seal material
Omit NBR Seals
V FPM Seals

8 Handle

Code symbol

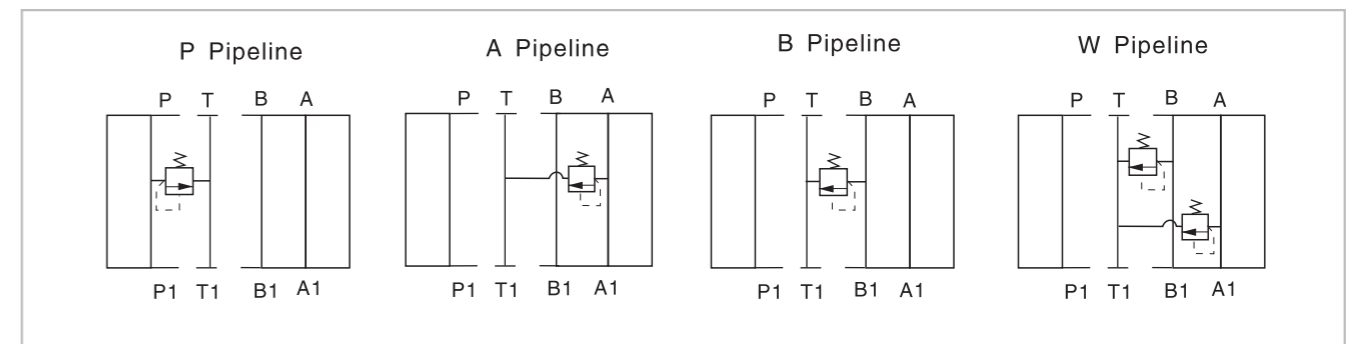

Modular Relief Valve

02 External dimensions

DY-02-A

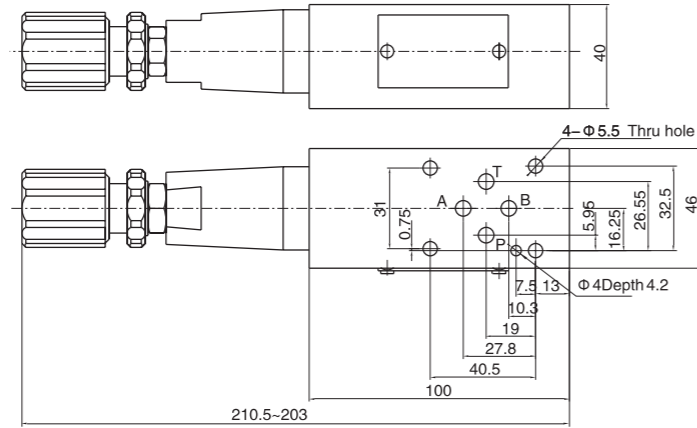

DY-02-B,P

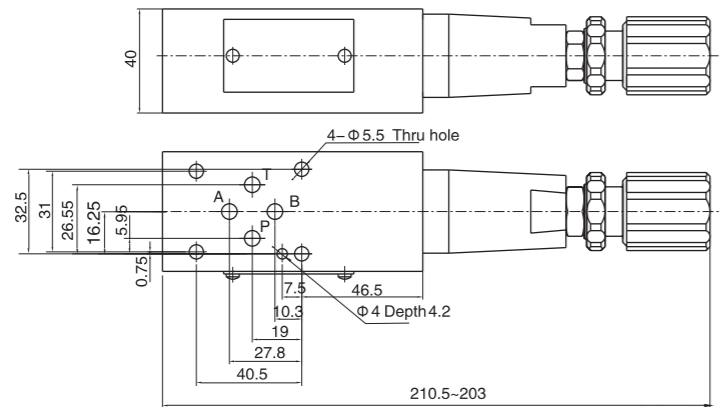

DY-02-W

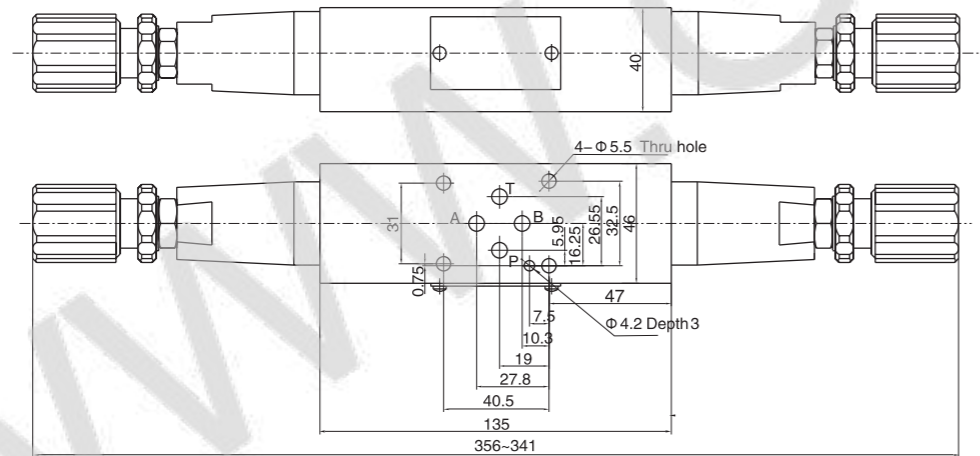

Modular Relief Valve

03 External dimensions

DY-03-A ...

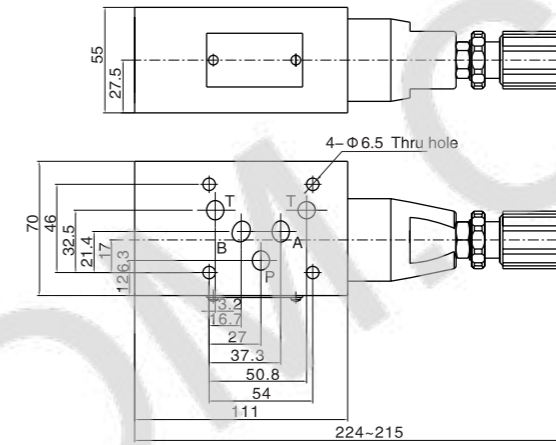

DY-03-B,P ...

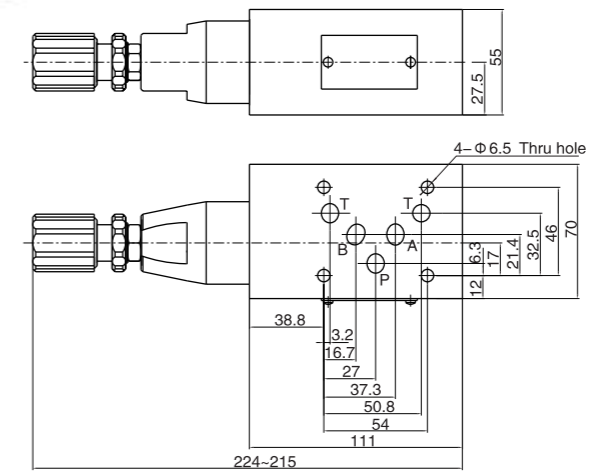

DY-03-W ...

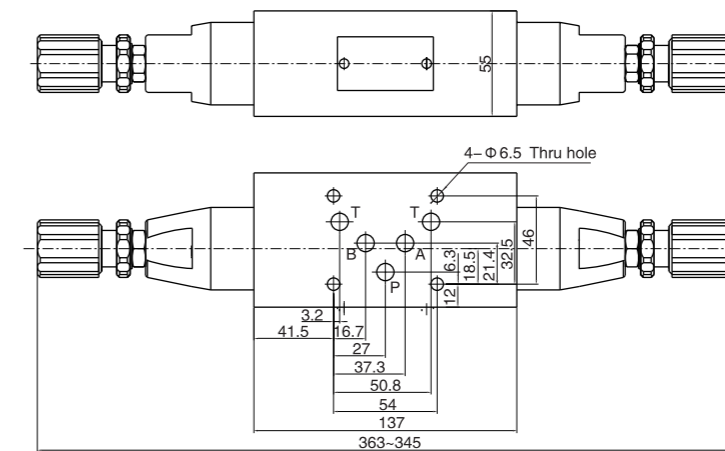

Modular Reducing Valve

Technical specification



Specification	02	03
Max. working pressure (MPa)	31.5	
Max. Flow (L/min)	35	70
Working fluid	Mineral oil; phosphate-ester	
Fluid temp. (°C)	-20~70	
Viscosity (mm ² /s)	12~380	
Working press (MPa)	7	14 21
Cleanliness	The maximum allowable cleanliness of the oil should be according to 9th degree of Standard NAS1638. It is suggested that the minimum filter rating should be $\beta_{10} \geq 75$.	

Model description

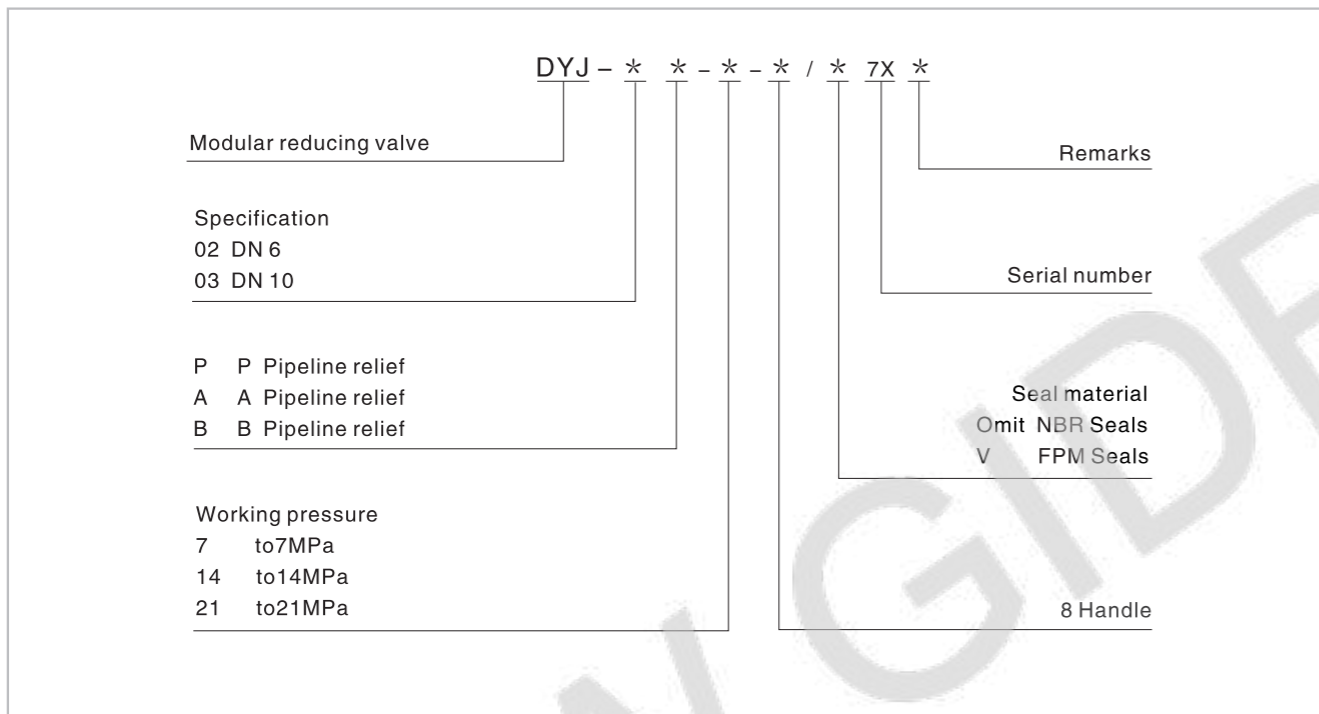

Code symbol

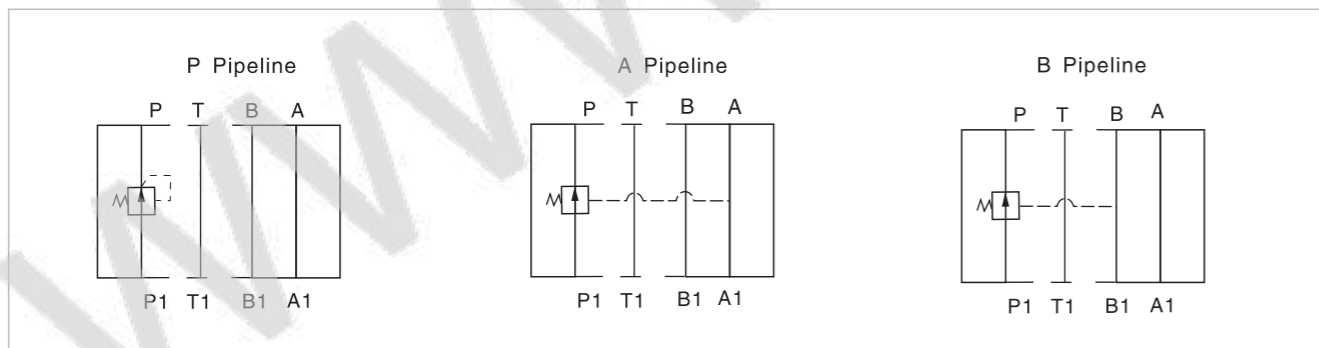

Modular Reducing Valve

02 External dimensions

DYJ-02-A , P ...

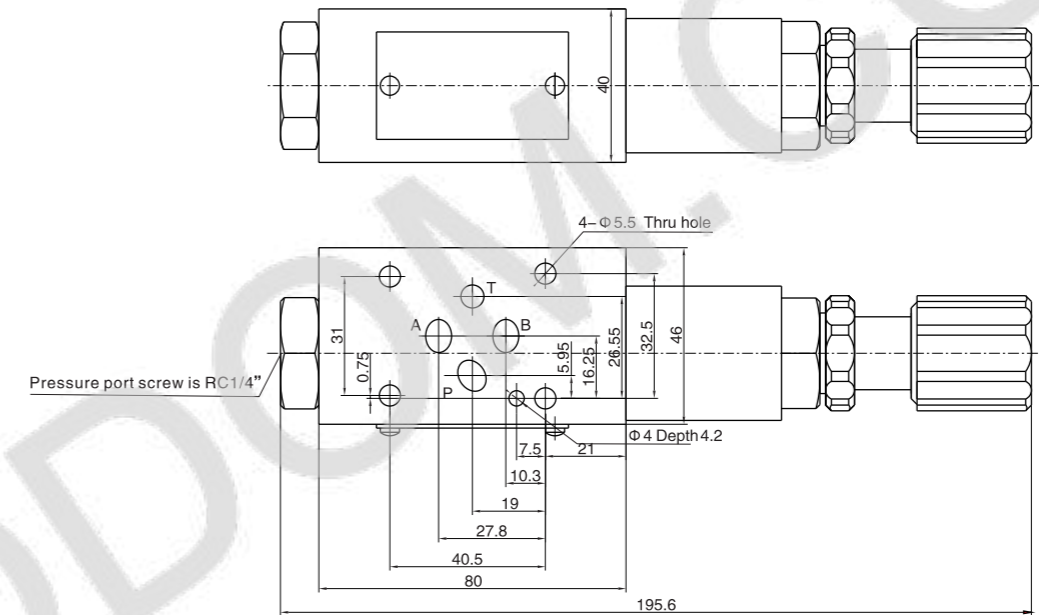

DYJ-02-B ...

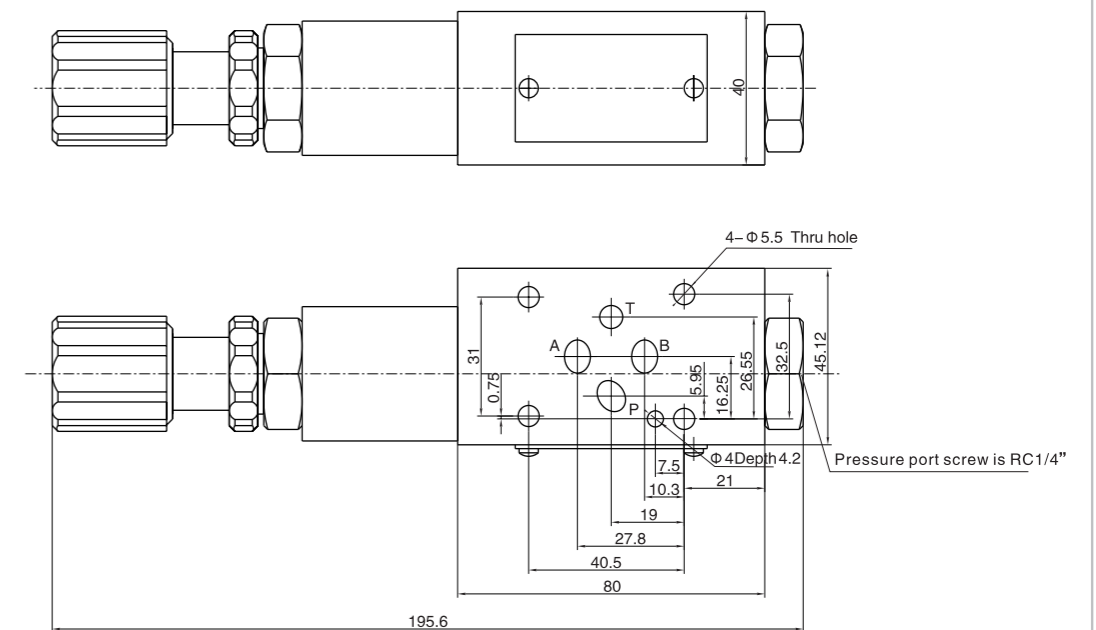

Modular Reducing Valve

03 External dimensions

DYJ-03-A, P ...

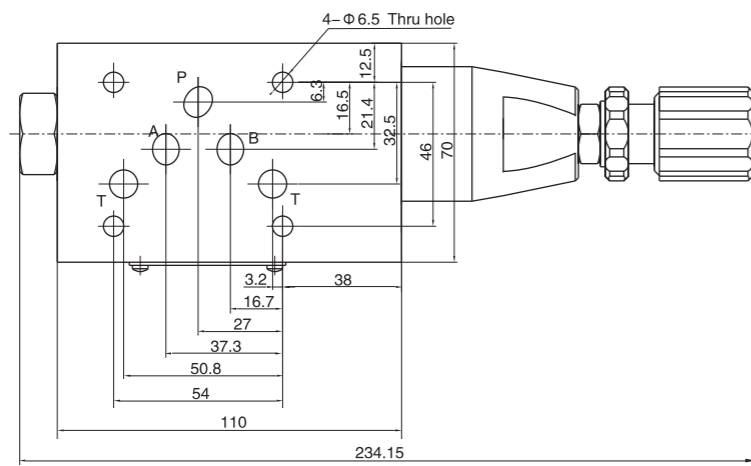
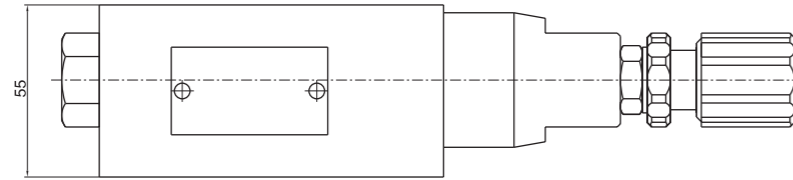

DYJ-03-B

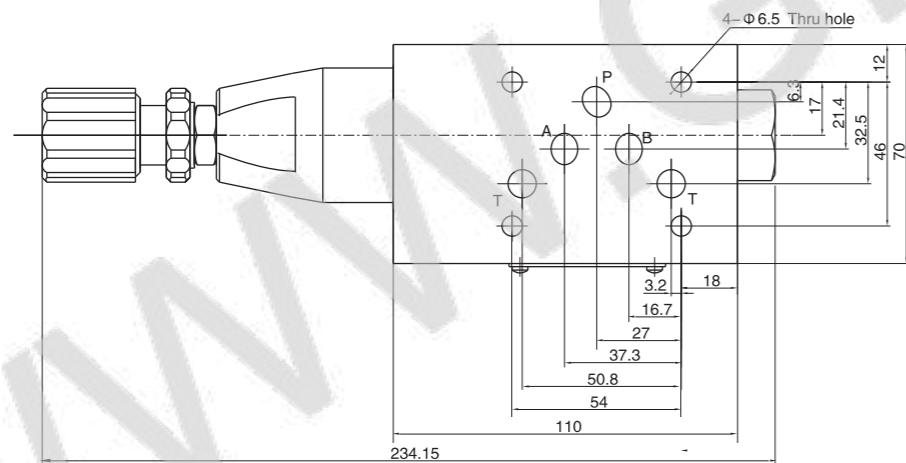
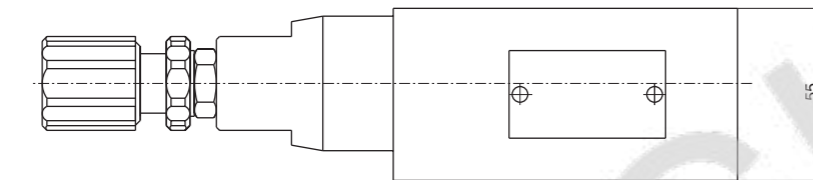

Modular Counter-balance Valve

Technical specification



Specification	02	03
Max. working pressure (MPa)	25	
Max. Flow (L/min)	35	70
Working fluid	Mineral oil; phosphate-ester	
Fluid temp. (°C)	-20~70	
Viscosity (mm ² /s)	12~380	
Adjusting pressure (MPa)	7, 14, 21	
Cleanliness	The maximum allowable cleanliness of the oil should be according to 9th degree of Standard NAS1638. It is suggested that the minimum filter rating should be β ₁₀ ≥ 75.	

Model description

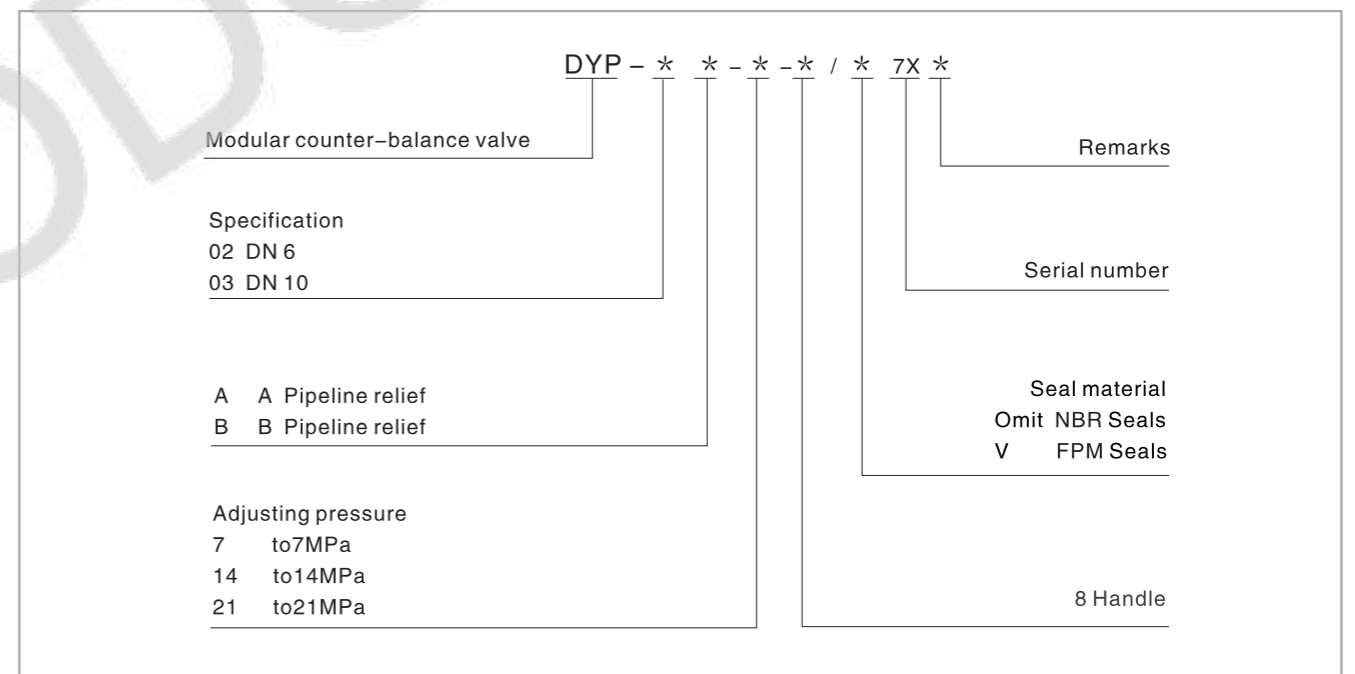

Code symbol

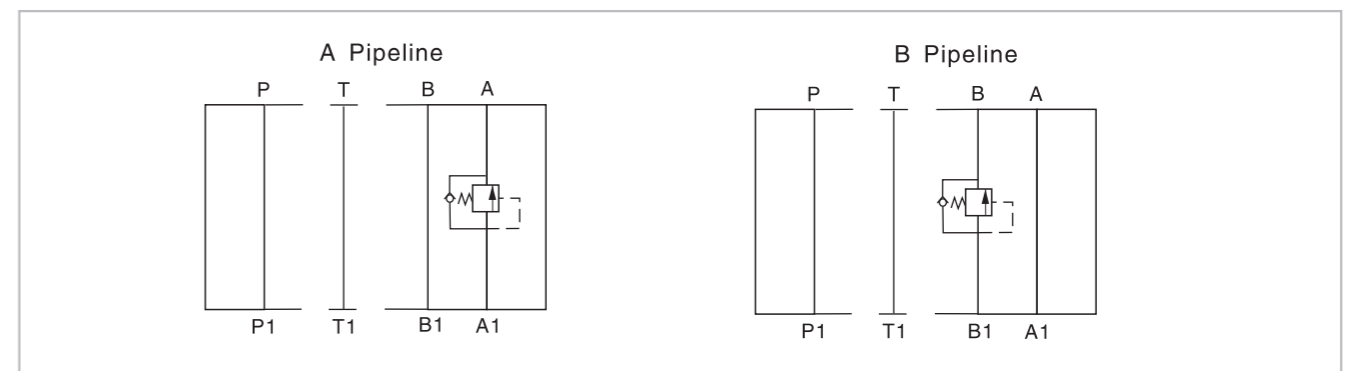

Modular Counter-balance Valve

02 External dimensions

DYP-02-A ...

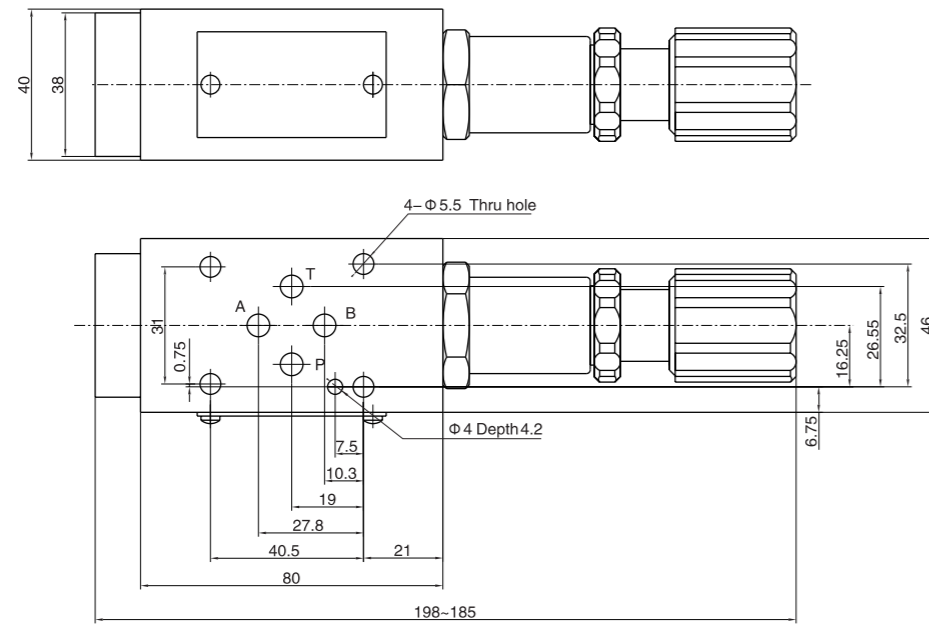

DYP-02-B ...

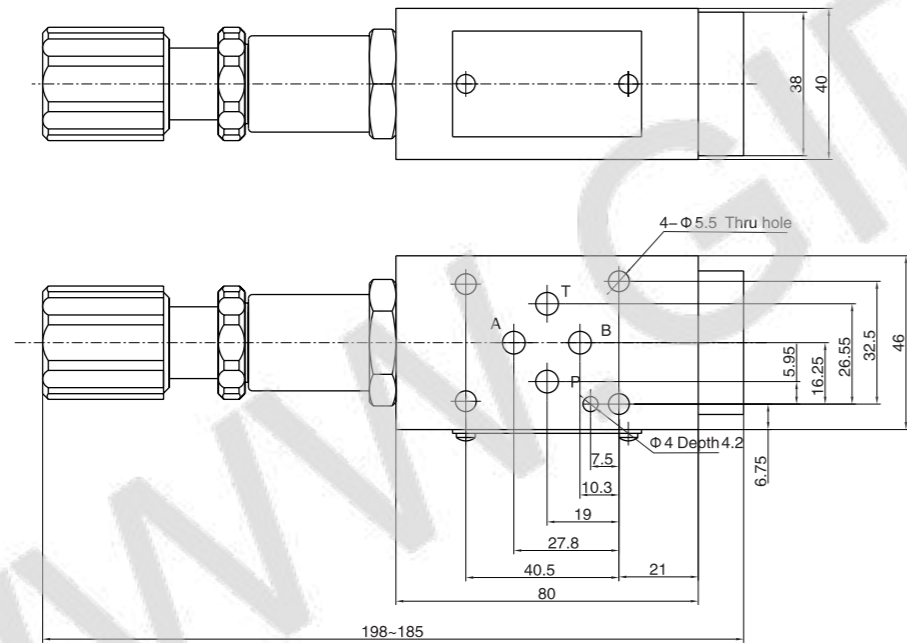

Modular Counter-balance Valve

03 External dimensions

DYP-03-A ...

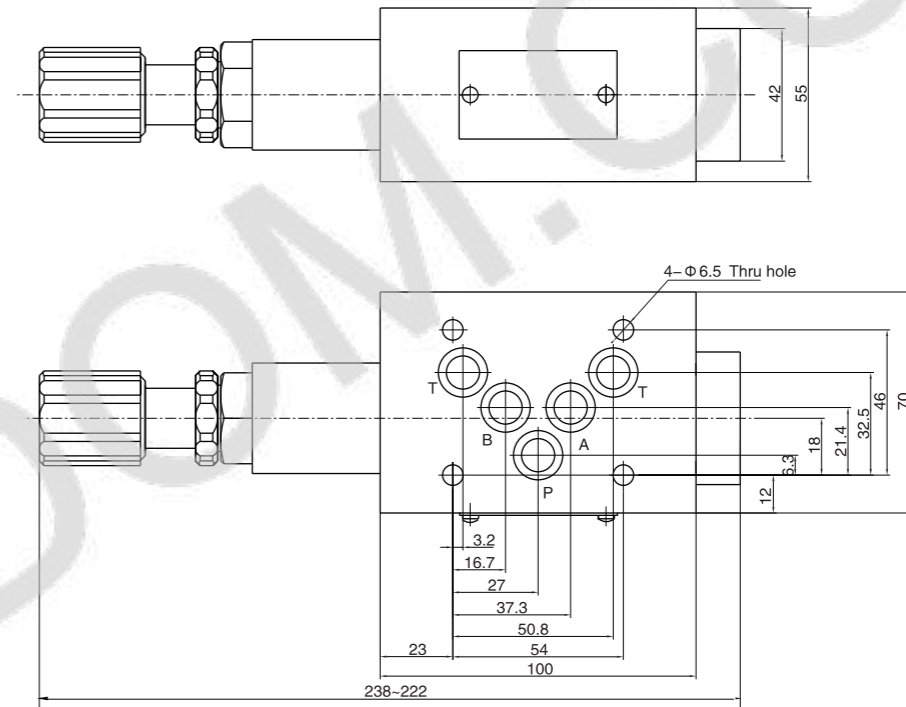

DYP-03-B ...

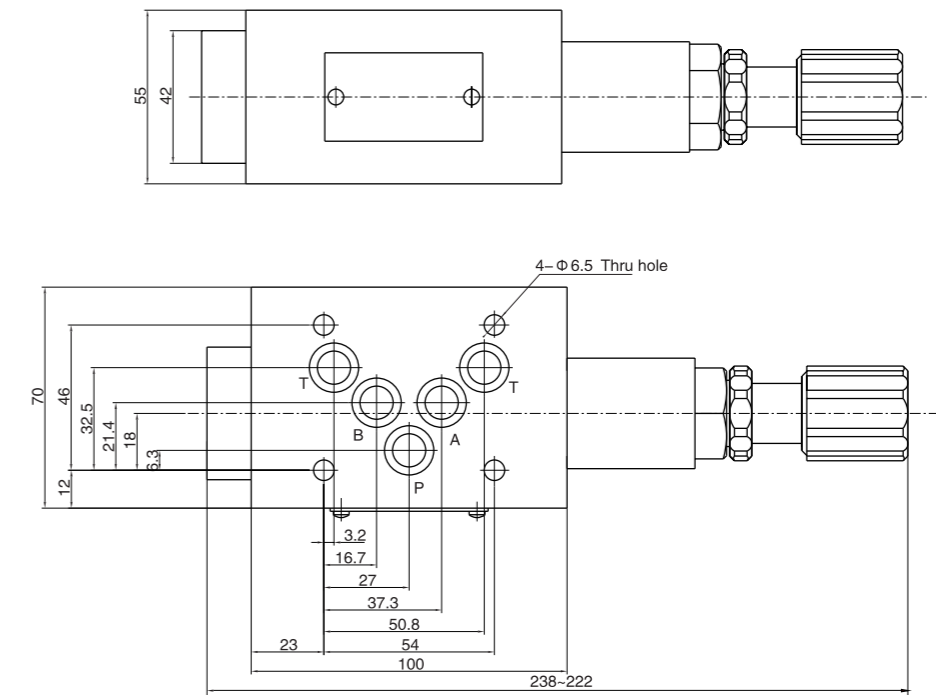

Piston-type Pressure Switch

Technical specification



The hydro-electric pressure switch type HED 8 is a piston type pressure switch. It basically comprises of housing, installation kit with piston, compression spring, adjustment element and micro switch. If the pressure to be monitored is below the set pressure, the micro switch is operated. The pressure to be monitored is applied via the nozzle at the piston. The piston is supported by the spring plate and acts against the continuously adjustable force of the compression spring. The spring plate transmits the movement of the piston onto the micro switch and releases the latter when the set pressure is reached. This switches the electric circuit on or off, depending on the circuit set-up. The mechanical positive stop of the spring plate protects the micro switch in case of a sudden pressure drop from mechanical destruction and, in case of over-pressure, prevents solid compression of the compression spring.

Model	HED 8	
	Max working pressure	Pressure setting range (Mpa)
Pressure range (Mpa) (Max setting pressure)	5	0.2-5
	10	0.4-10
	20	0.5-20
	35	0.8-35
working fluid	Mineral oil according to standard Din 51524 (HL, HLP)	
Fluid temp (°C)	-20~+80 (recommended +40~+50)	
Fluid viscosity (mm²/s)	20-380 (recommended 30-46)	
Cleanliness	According to NAS1638 class9, recommended filter fineness (20 ≤ δ ≤ 50)	
Switching accuracy (repetition accuracy)	<±1% of the set pressure	
Max switching frequency (1/h)	4800	
Electrical connection	Din 43650, type A, 3-pole + PE	
Max connection cross sectional area mm²	0.5	
Max contact loading	-AC	250V; 5A
	-DC	50V/1A; 125V/0.03A; 250V/0.02A
protection class as per Din 40050	IP65	

If it is direct-current inductive load, it is necessary to use arc extinguisher for longer serve life purpose.
(For applications outside these parameters, please consult us!)

Piston-type Pressure Switch

Performance curve

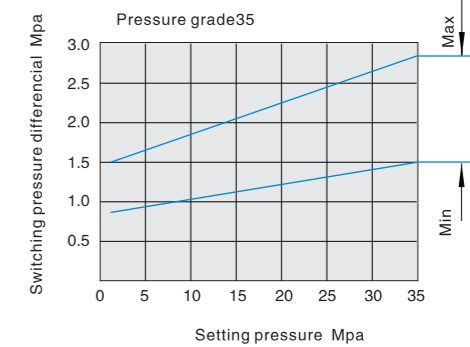
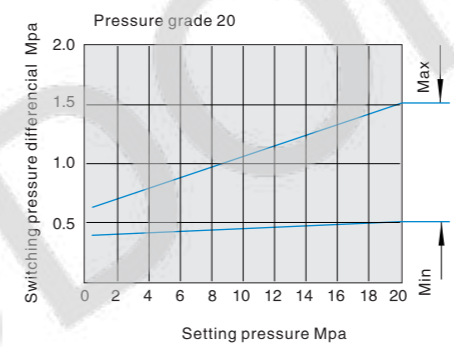
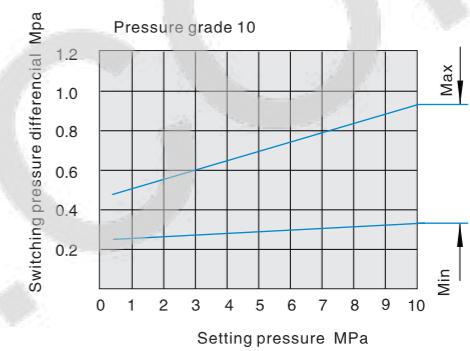
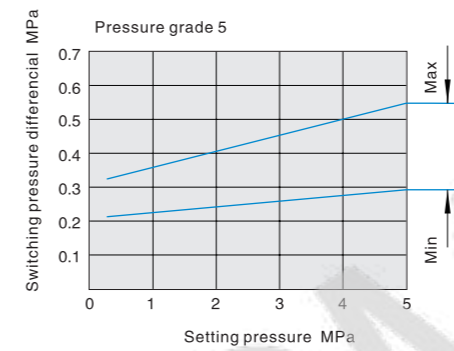

Ordering code

HED 8 - * - L1 * - / - * * / * *

Piston-type pressure switch	Omit	NBR
Flange mounting OH	V	FPM
Subplate mounting OP		
Pipe mounting OA		

For pipe mounting
Omit G1/4
2 M14x1.5

L10-L19series L1X
L10-L19series unchanged mounting size

5 Max setting pressure 5MPa
10 Max setting pressure 10MPa
20 Max setting pressure 20MPa
35 Max setting pressure 35MPa

Electrical connection
Din plug Z14
Din plug with LED (DC24V) L24

Code symbol

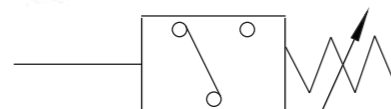

Dimension (HED 8 OA L1X/ pipe type)

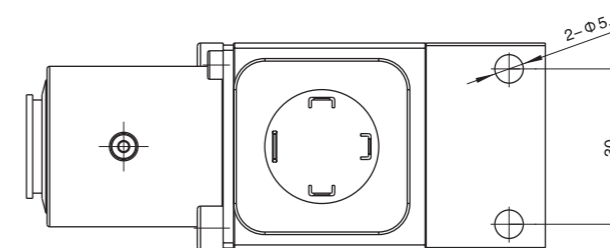
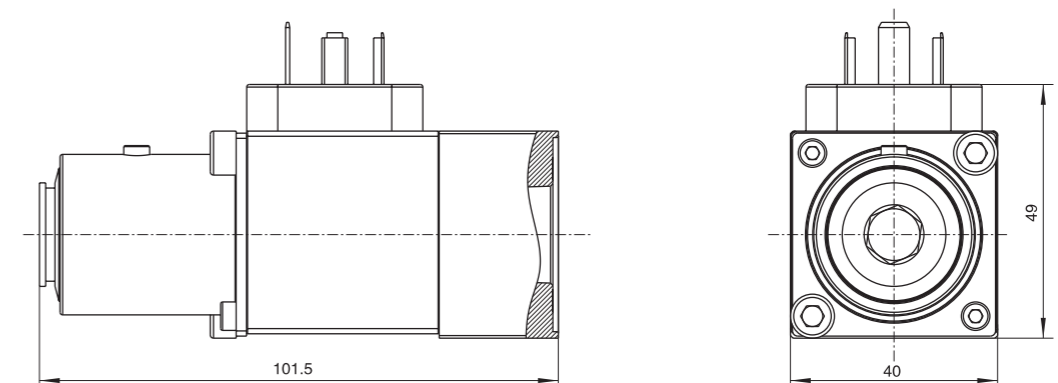

Note: In order for long serve time, the product shall be
1. mounted for quake-proof
2. reducing hydraulic impact

HOYEA

Flow Control Valve Series



WWW.GIDRODOM.COM

Needle Valve

Technical specification



Specification	6	8	10	12	16	20	25	30	40
Max.pressure(MPa) (MPa)	31.5								
Max.flow (L/min)	14	40	60	85	175	200	300	400	600
Hydraulic fluid	Mineral oil; phosphate-ester								
Fluid temp (°C)	-20~70								
Viscosity (mm ² /s)	2.8~380								
Cleanliness	The maximum allowable cleanliness of the oil should be according to 9th degree of Standard NAS1638. It is suggested that the minimum filter rating should be $\beta_{10} \geq 75$.								

Needle valve is used to control the flow by changing the throttle section or length.
Needle valve is a simple flow control valve, which can constitute the throttle system with other components.

Model instruction

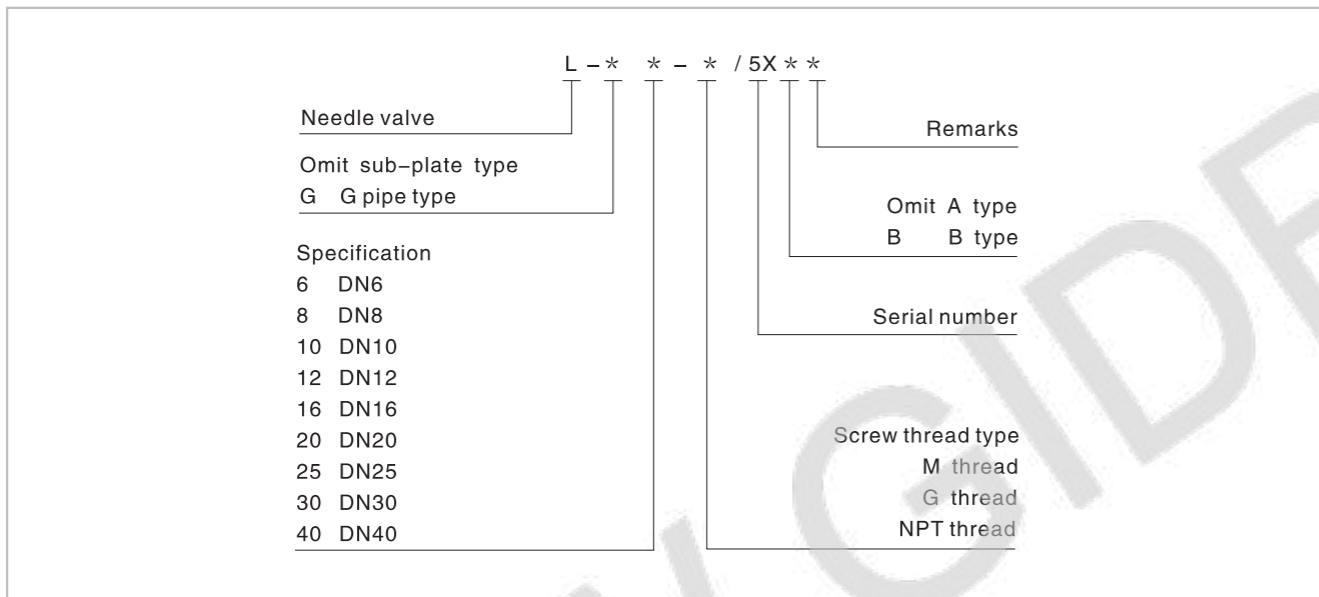

Code symbol

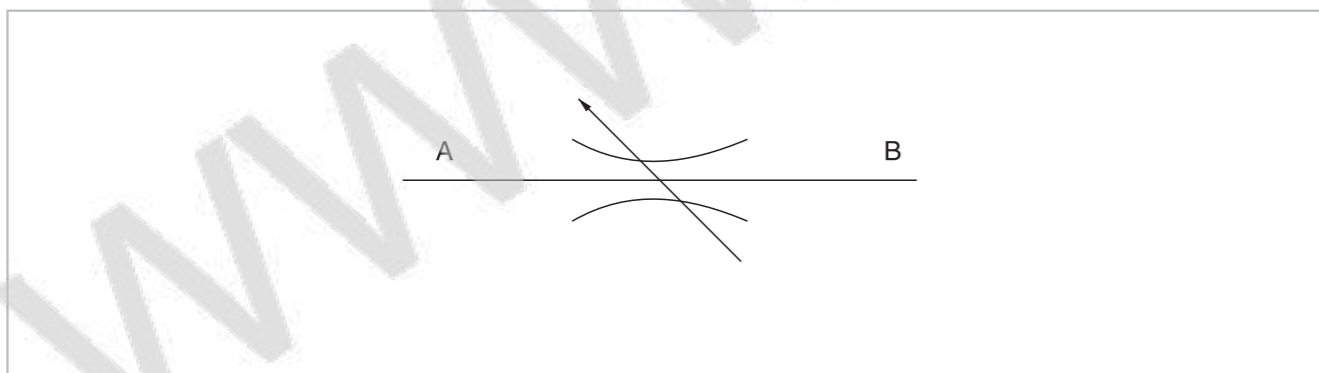

Needle Valve

External dimensions

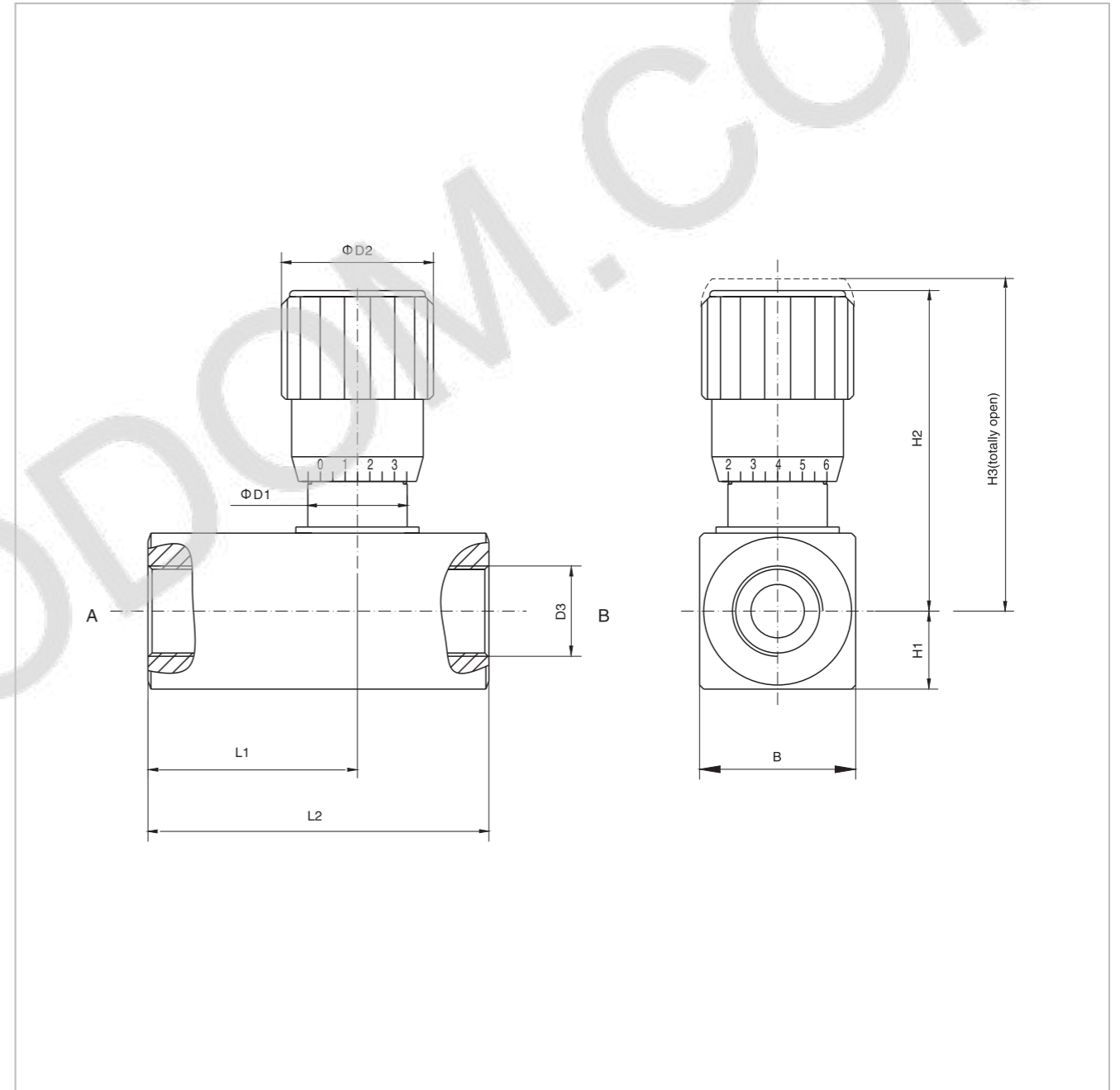

Model	B	D1	D2	D3			H1	H2	H3	L1	L2
G6	28	19.3	30	M10X1	G1/8"	NPT1/8"	14	59.3	64.8	26	48
G8	28	19.3	30	M14X1.5	G1/4"	NPT1/4"	14	61.3	67.9	28	54
G10	28	19.3	30	M18X1.5	G3/8"	NPT3/8"	14	61.5	67.5	28	54
G12	38	24.2	37	M22X1.5	G1/2"	NPT1/2"	19	78.1	86.5	34	68
G16	38	24.2	37	M27X2	G3/4"	NPT3/4"	19	78.3	86.5	39	78
G20	48	35	48	M33X2	G1"	NPT1"	24	102.3	114.4	45.8	92
G25	60	50	48	M42X2	G1 1/4"	NPT1 1/4"	30	134.68	148.1	57	114
G30	70	70	80	M48X2	G1 1/2"	NPT1 1/2"	35	161.5	181.5	61	122
G40	90	71	80	M60X2	G2"	NPT2"	45	171.5	191.5	61	122

Check Restrictive Valve

Technical specification



Specification	6	8	10	12	16	20	25	30	40
Max.pressure (MPa)	31.5								
Max.flow (L/min)	14	40	60	85	175	200	300	400	600
Hydraulic fluid	Mineral oil;phosphate-ester								
Fluid temp (°C)	-20~70								
Viscosity (mm ² /s)	2.8~380								
Opening pressure (MPa)	a: 0.05 b:0.4								
Cleanliness	The maximum allowable cleanliness of the oil should be according to 9th degree of Standard NAS1638.It is suggested that the minimum filter rating should be $\beta_{10} \geq 75$.								

1-way restrictive valve consists of needle valve and 1-way valve in parallel. It is used to adjust the flow in one way, and reverse back freely.

Model instruction

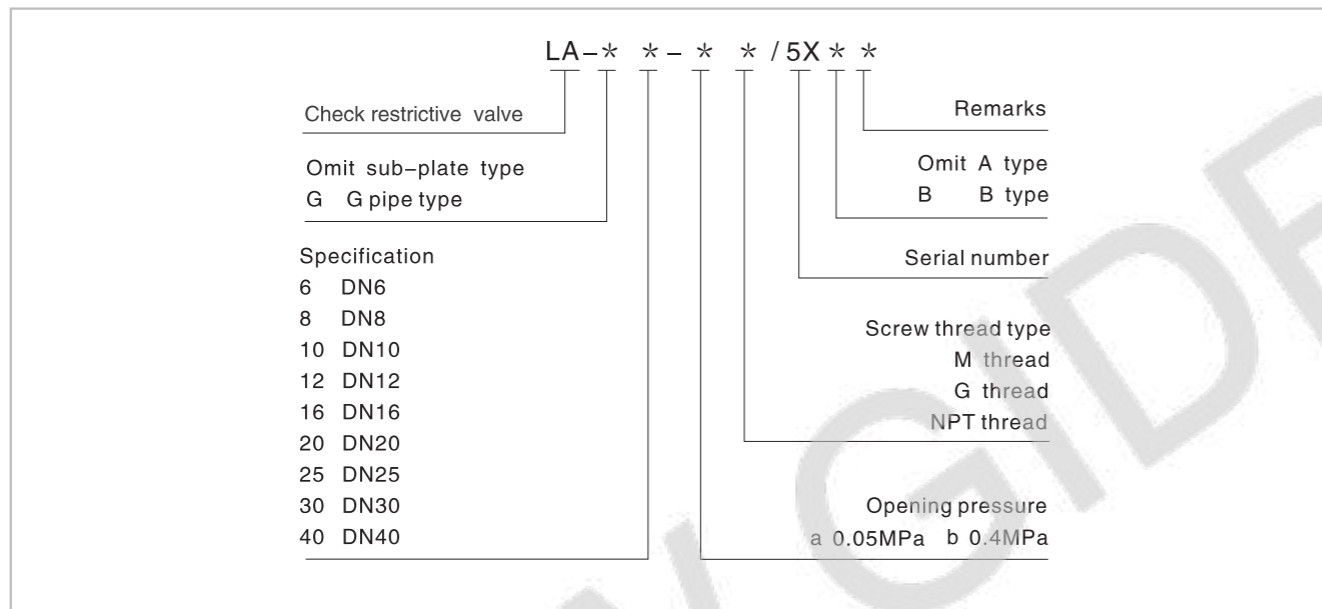

Code symbol

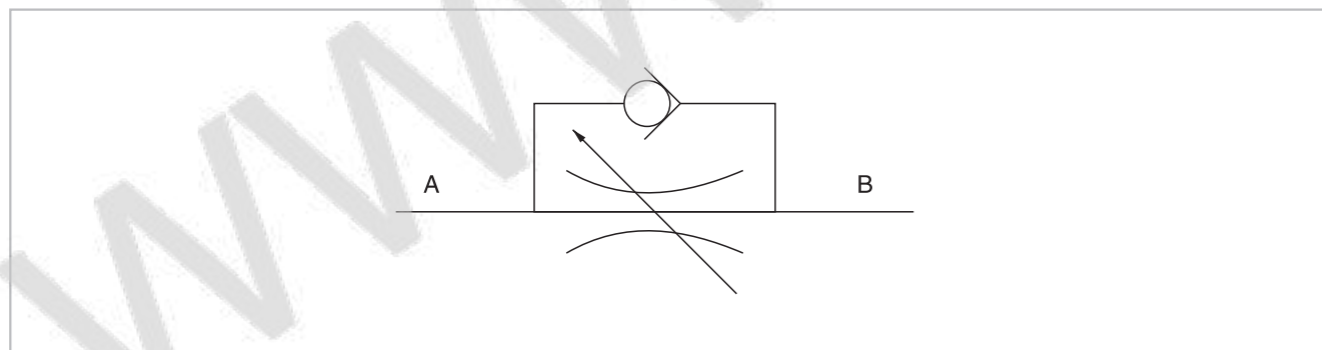

Check Restrictive Valve

External dimensions

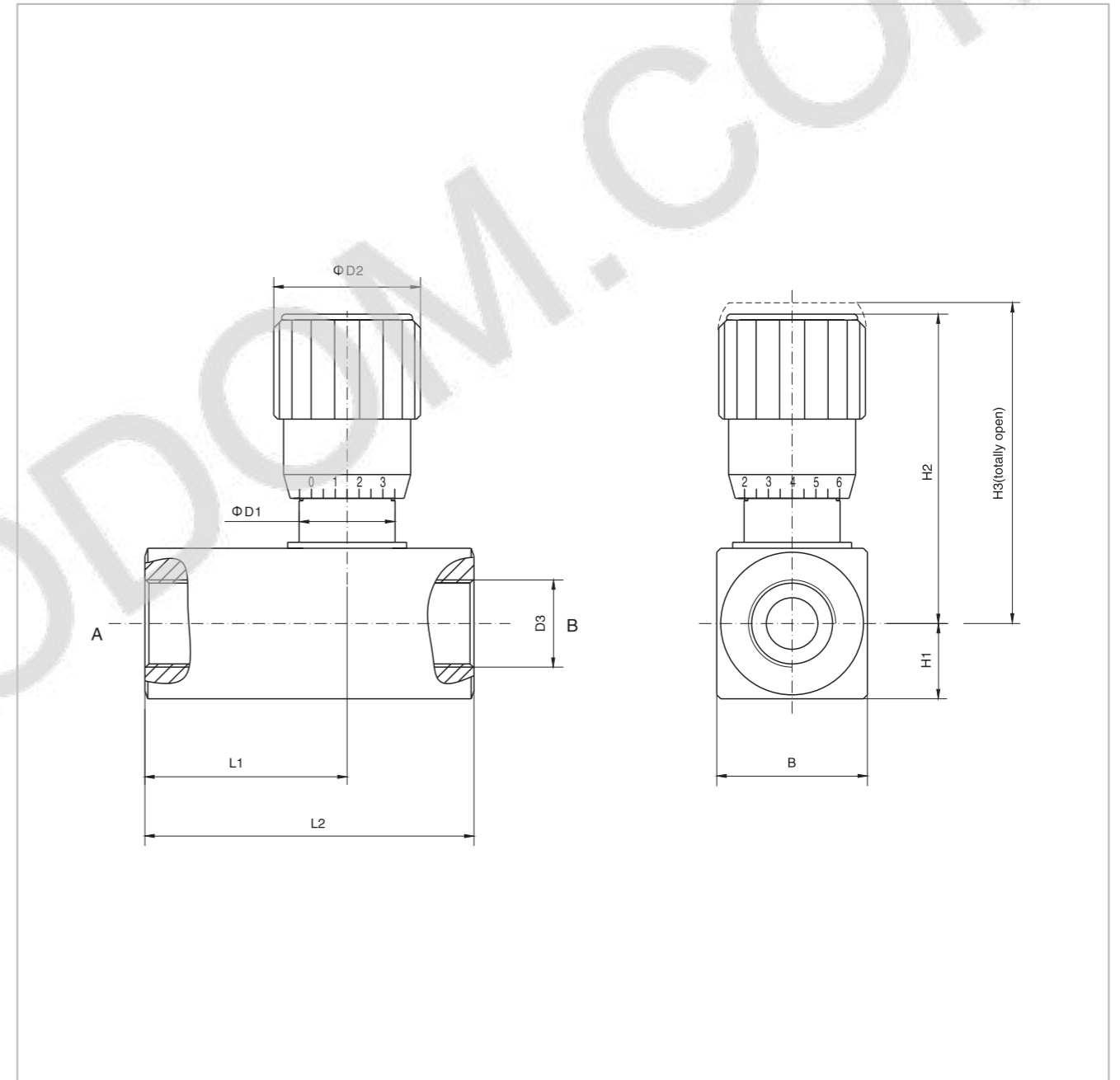

Model	B	D1	D2	D3			H1	H2	H3	L1	L2
G6	28	19.3	30	M10X1	G1/8"	NPT1/8"	14	59.3	64.8	36	58
G8	28	19.3	30	M14X1.5	G1/4"	NPT1/4"	14	61.3	67.9	39	64
G10	28	19.3	30	M18X1.5	G3/8"	NPT3/8"	14	61.5	67.5	43	70
G12	38	24.2	37	M22X1.5	G1/2"	NPT1/2"	19	78.1	86.5	52	83
G16	38	24.2	37	M27X2	G3/4"	NPT3/4"	19	78.3	86.5	55.5	89
G20	48	35	48	M33X2	G1"	NPT1"	24	102.3	114.4	70.8	117
G25	60	50	48	M42X2	G1 1/4"	NPT1 1/4"	30	134.68	148.1	97	154
G30	70	70	80	M48X2	G1 1/2"	NPT1 1/2"	35	161.5	181.5	111	172
G40	90	71	80	M60X2	G2"	NPT2"	45	171.5	191.5	129	190

Restrictive Check Valve

Technical specification



Specification	10	12	16	20
Max.pressure (MPa)	31.5			
Max.flow (L/min)	60	85	175	200
Hydraulic fluid	Mineral oil;phosphate-ester			
Fluid temp (°C)	-20~70			
Viscosity (mm ² /s)	2.8~380			
Opening pressure (MPa)	a: 0.05 b:0.4			
Cleanliness	The maximum allowable cleanliness of the oil should be according to 9th degree of Standard NAS1638.It is suggested that the minimum filter rating should be $\beta_{10} \geq 75$.			

Restrictive check valve consists of restrictive valve and 1-way valve in series. It can control the flow and only allows the flow in one way. Flow will be shut off in the opposite direction.

Model instruction

Restrictive check valve	AL-*	*-*	* /5X *	Remarks
Omit sub-plate type G G pipe type				Serial number
Specification				Screw thread type M thread G thread NPT thread
10 DN10				Opening pressure a 0.05MPa b 0.4MPa
12 DN12				
16 DN16				
20 DN20				

Code symbol

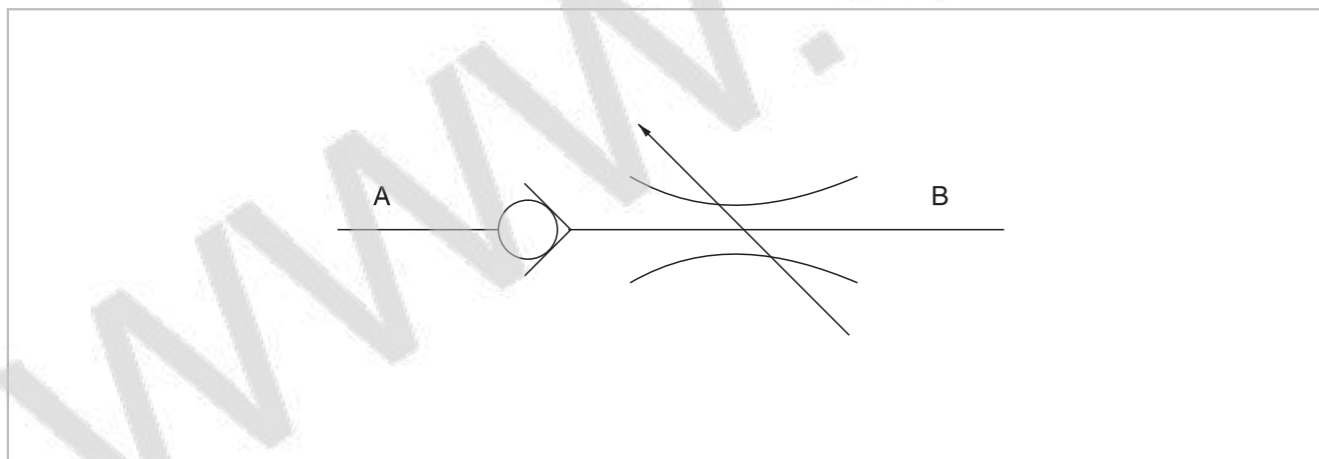

Restrictive Check Valve

External dimensions

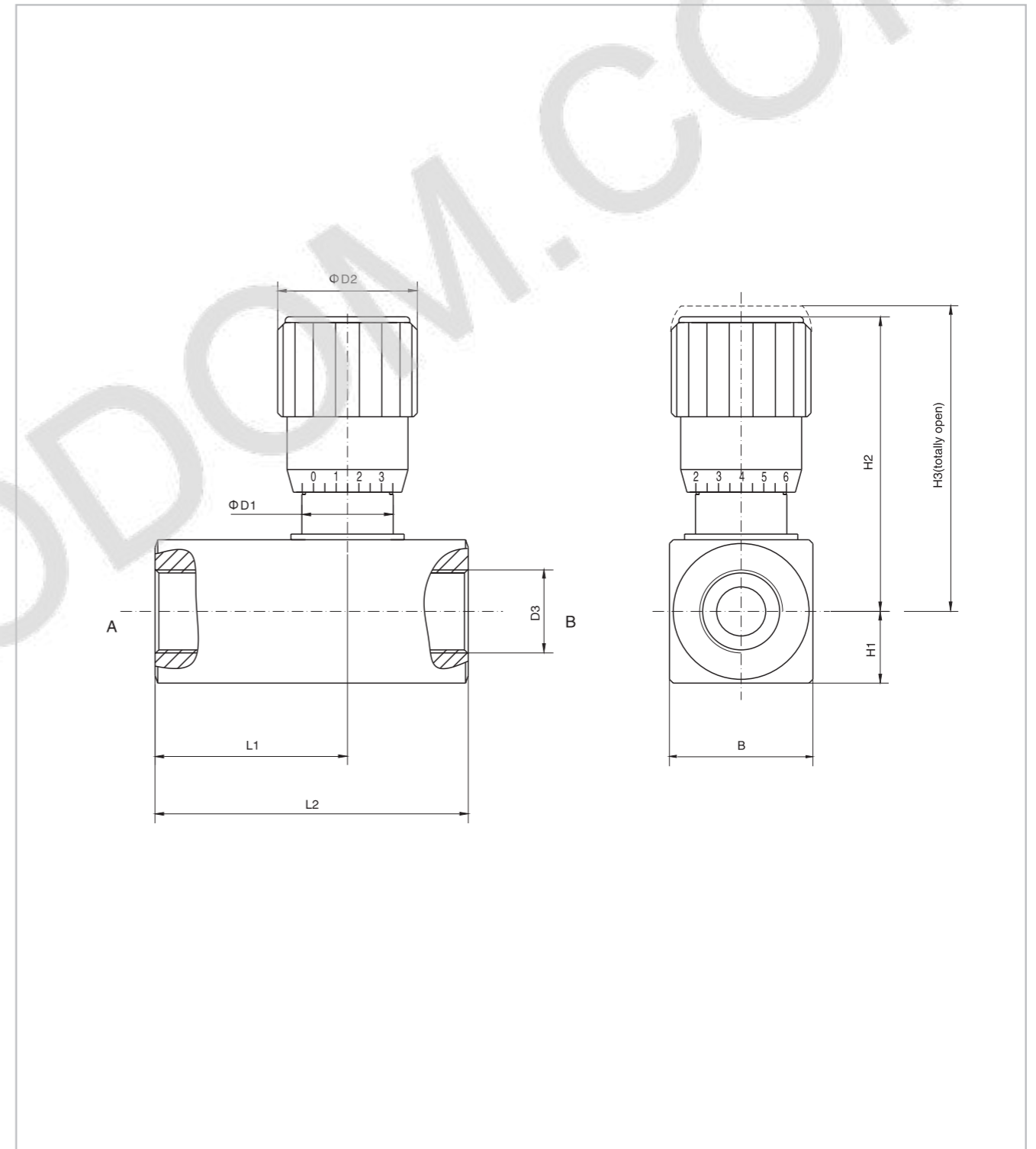

Model	B	D1	D2	D3			H1	H2	H3	L1	L2
G10	28	19.3	30	M18X1.5	G3/8"	NPT 3/8"	14	61.5	67.5	45.5	73
G12	38	24.2	37	M22X1.5	G1/2"	NPT 1/2"	19	78.1	86.5	54	86
G16	38	24.2	37	M27X2	G3/4"	NPT 3/4"	19	78.3	86.5	59	94
G20	48	35	48	M33X2	G1"	NPT 1"	24	102.3	114.4	74.8	123

Modular Restrictive Valve

Technical specification



Specification	02	03
Max.pressure (MPa)	31.5	
Max.flow (L/min)	30	50
Hydraulic fluid	Mineral oil;phosphate-ester	
Fluid temp (°C)	-20~70	
Viscosity (mm ² /s)	2.8~380	
Cleanliness	The maximum allowable cleanliness of the oil should be according to 9th degree of Standard NAS1638.It is suggested that the minimum filter rating should be β 10≥75.	

Model instruction

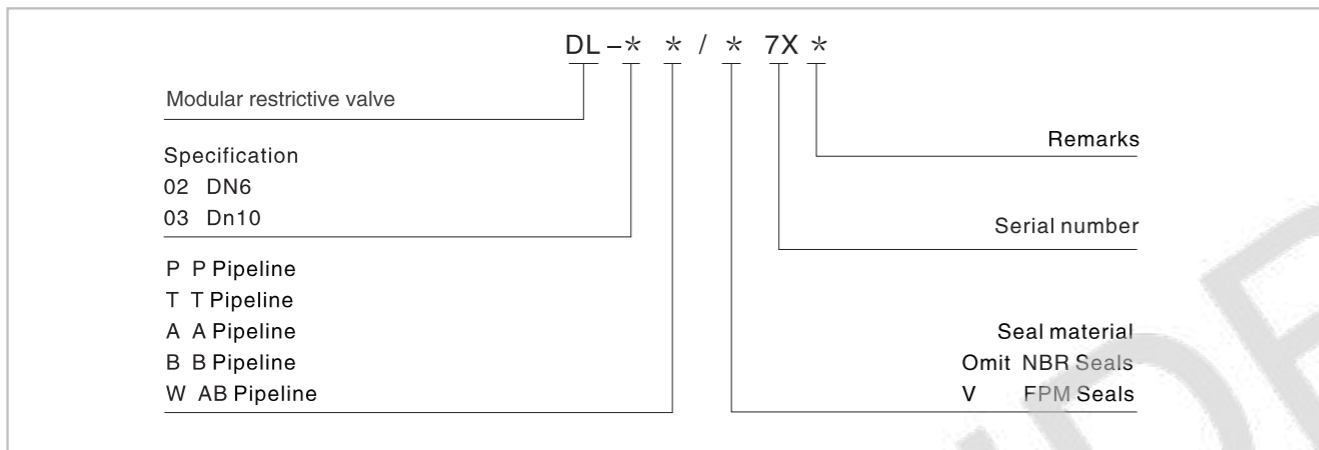

Code symbol

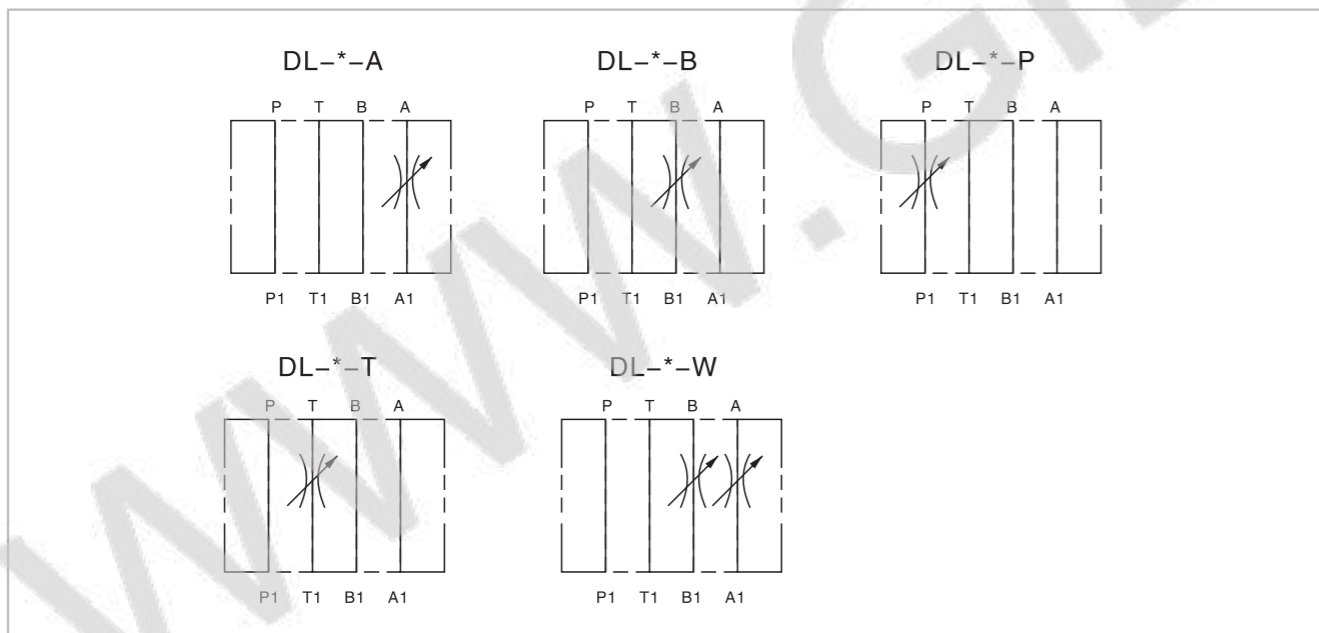

Modular Restrictive Valve

External dimensions

DL-02-A/ ...

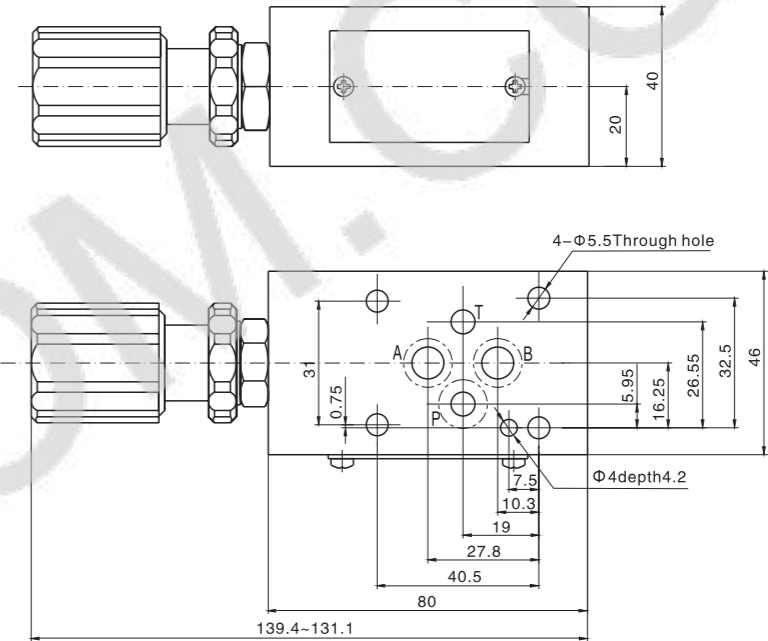

DL-02-P,B,T/ ...

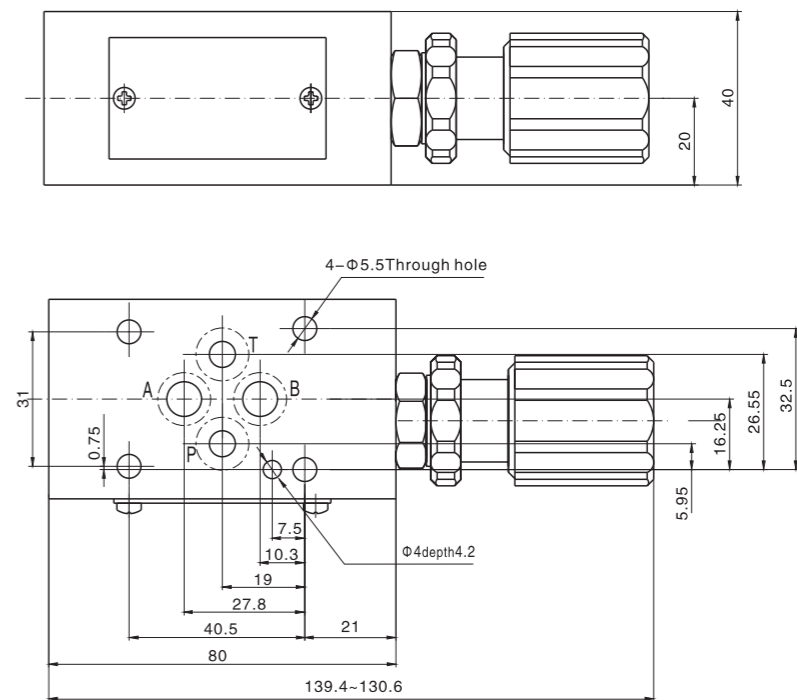

Notice: The surface, connecting with the valve, should be Ra0.8 roughness, and 0.01/100mm flatness.

Modular Restrictive Valve

External dimensions

DL-02-W/ ...

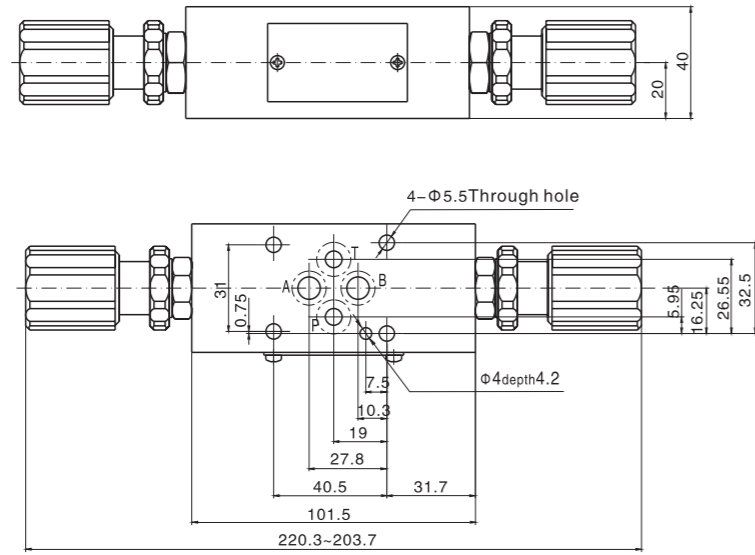

DL-03-A/ ...

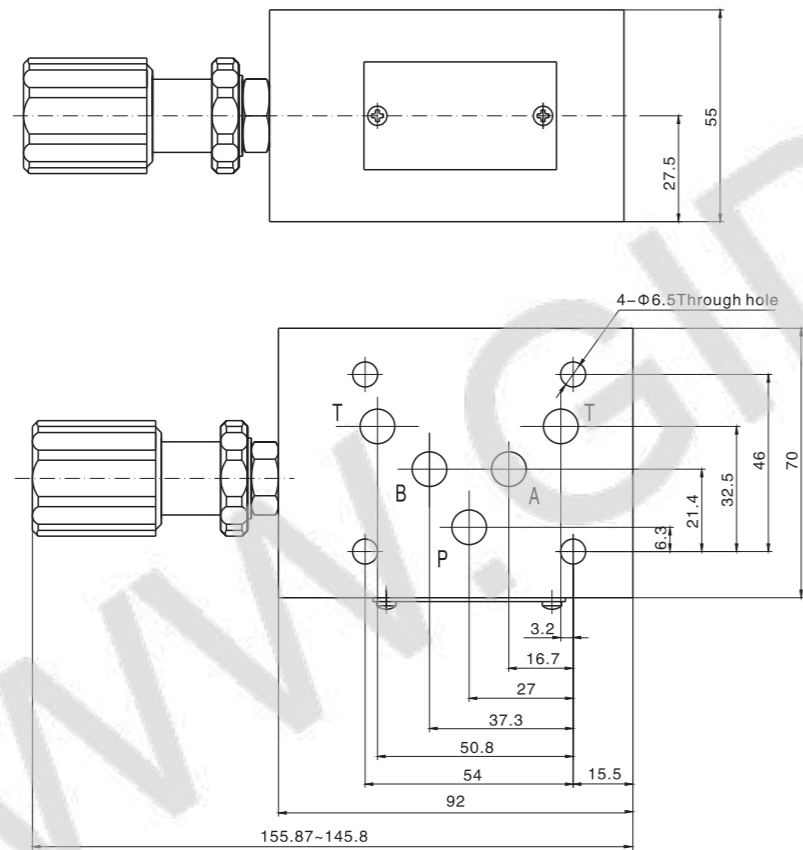

Notice: The surface, connecting with the valve, should be Ra0.8 roughness, and 0.01/100mm flatness.

Modular Restrictive Valve

External dimensions

DL-03-P,B,T/ ...

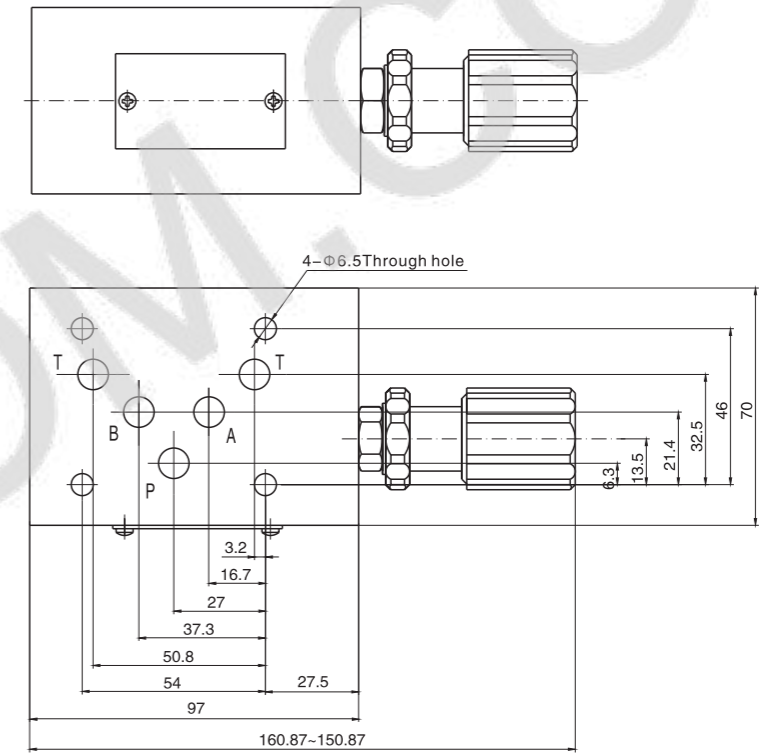

DL-03-W/ ...

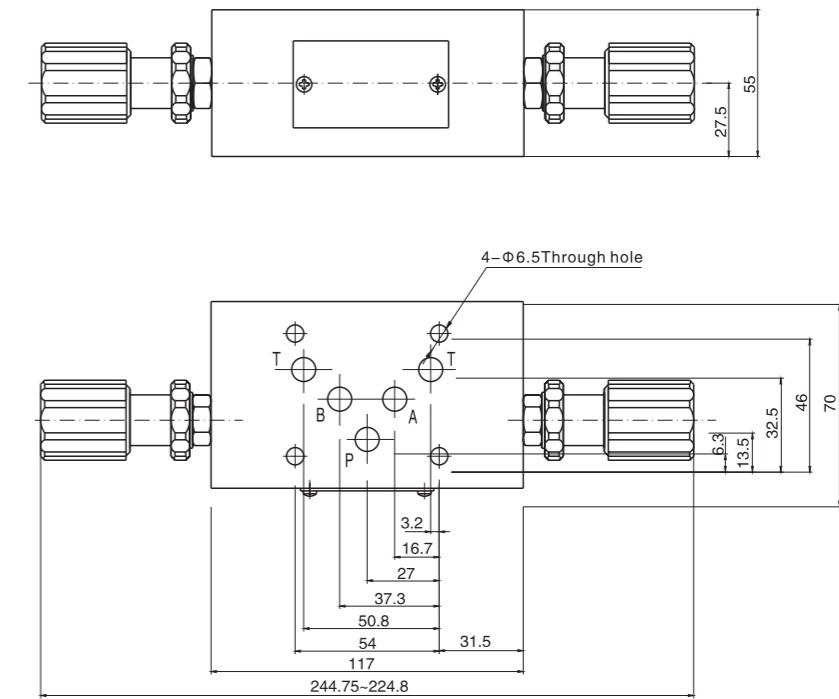

Notice: The surface, connecting with the valve, should be Ra0.8 roughness, and 0.01/100mm flatness.

Modular Flow Control Valve

Technical specification



Specification	02	03
Max.pressure (MPa)	31.5	
Max.flow (L/min)	30	50
Hydraulic fluid	Mineral oil;phosphate-ester	
Fluid temp (°C)	-20~70	
Viscosity (mm ² /s)	2.8~380	
Opening pressure (MPa)	a: 0.05	
Cleanliness	The maximum allowable cleanliness of the oil should be according to 9th degree of Standard NAS1638.It is suggested that the minimum filter rating should be $\beta_{10} \geq 75$.	

Model instruction

Modular flow control valve	DLA-* * -* * / * 7X *	Remarks
Specification		Serial number
02 DN6		Seal material
03 DN10		Omit NBR Seals
A A Pipeline		V FPM Seals
B B Pipeline		
W AB Pipeline		Throttle direction
Opening pressure		Omit meter out
a 0.05MPa		1 meter in

Code symbol

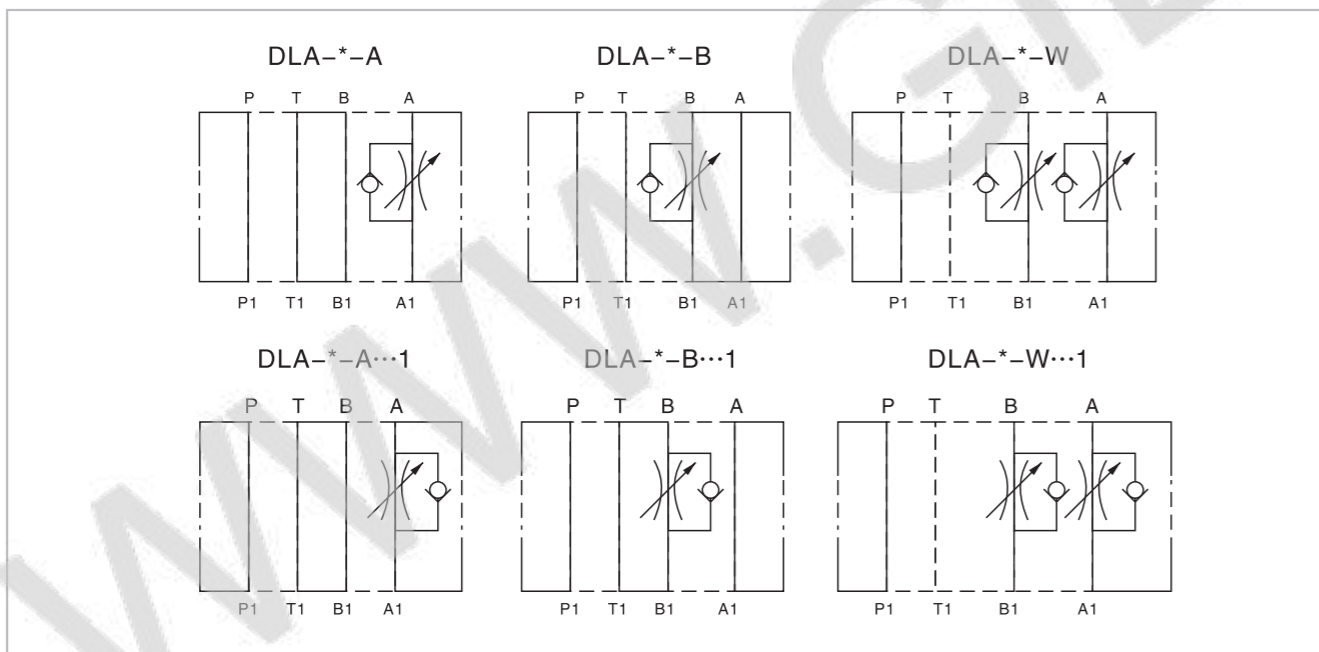

Modular Flow Control Valve

External dimensions

DLA-02- ...

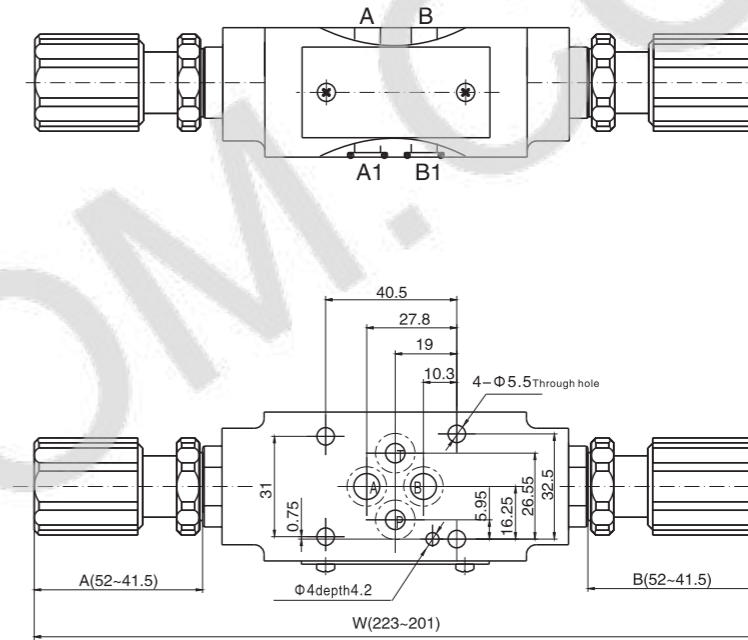

DLA-02- ... 1/ ...

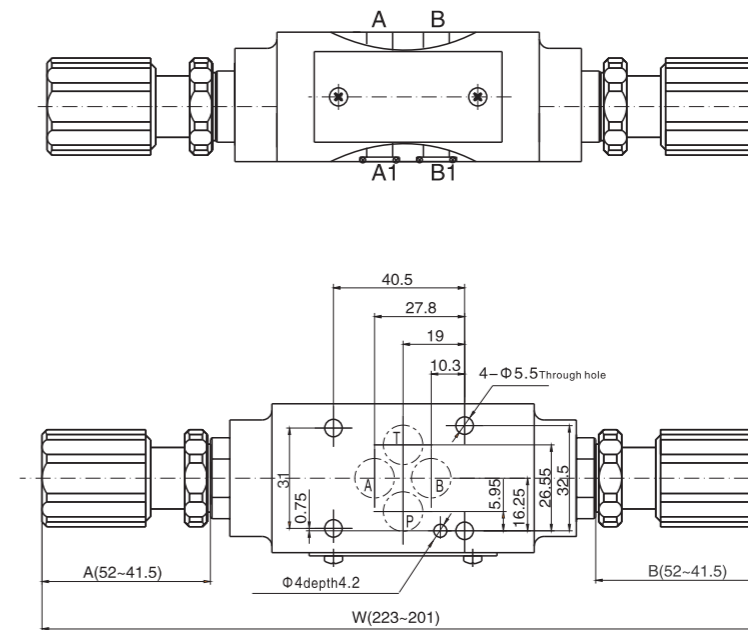

Notice: The surface, connecting with the valve, should be Ra0.8 roughness, and 0.01/100mm flatness.

Modular Flow Control Valve

External dimensions

DLA-03- ...

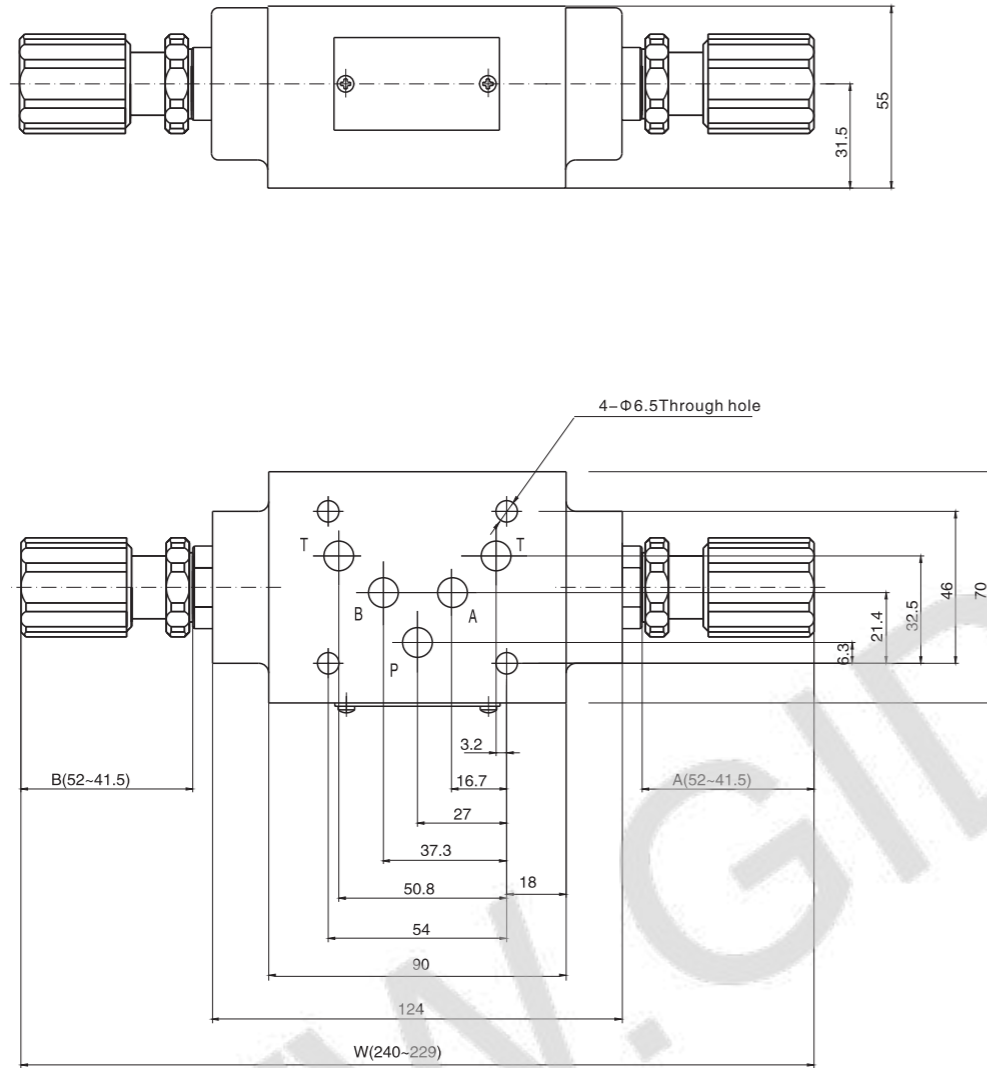

Notice: The surface, connecting with the valve, should be Ra0.8 roughness, and 0.01/100mm flatness.

Modular Flow Control Valve

External dimensions

DLA-03- ... 1/ ...

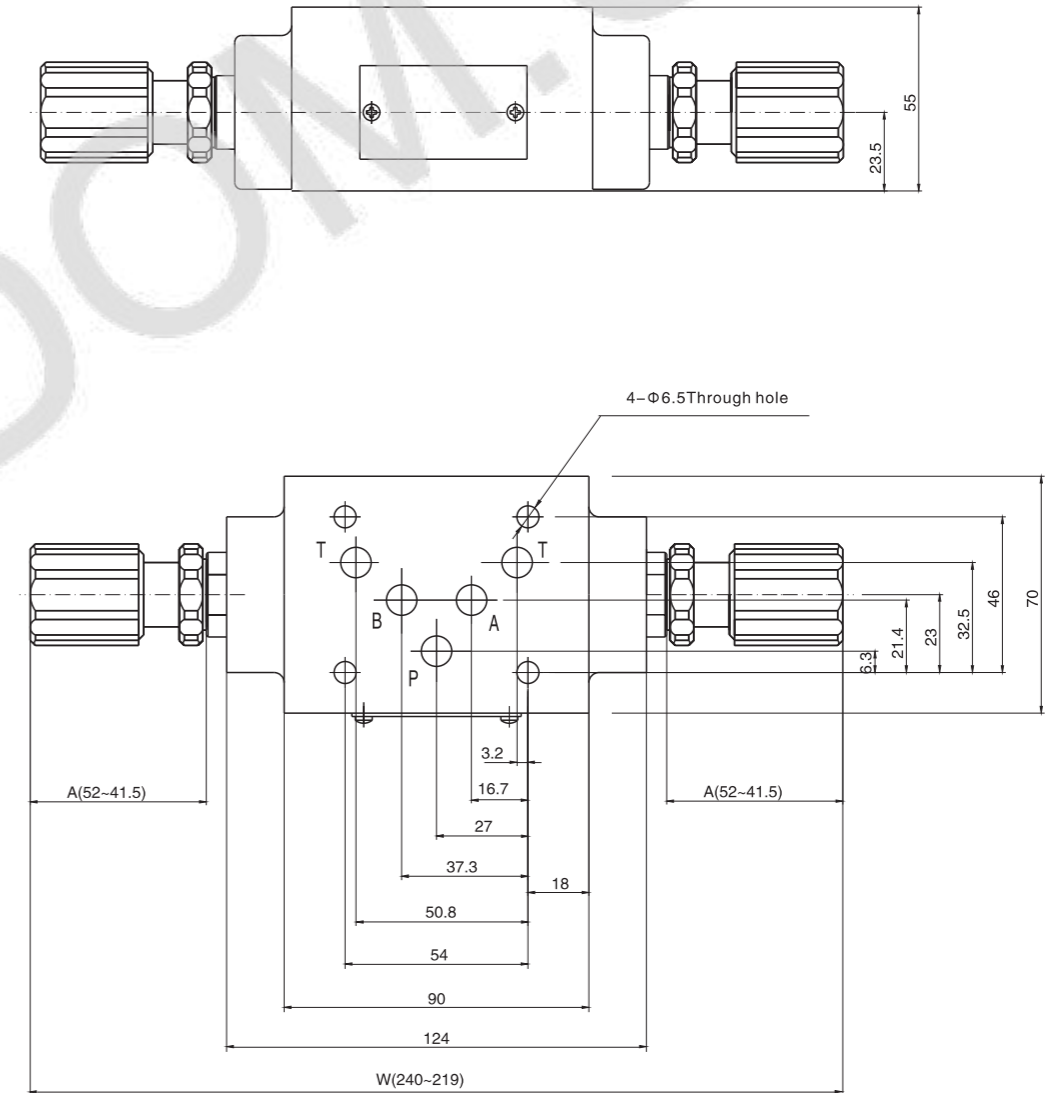

Notice: The surface, connecting with the valve, should be Ra0.8 roughness, and 0.01/100mm flatness.

Modular Restrictive Check Valve

Technical specification



Specification	02	03
Max.pressure (MPa)	31.5	
Max.flow (L/min)	30	50
Hydraulic fluid	Mineral oil;phosphate-ester	
Fluid temp (°C)	-20~70	
Viscosity (mm ² /s)	2.8~380	
Opening pressure (MPa)	a: 0.05	
Cleanliness	The maximum allowable cleanliness of the oil should be according to 9th degree of Standard NAS1638.It is suggested that the minimum filter rating should be $\beta_{10} \geq 75$.	

Model instruction

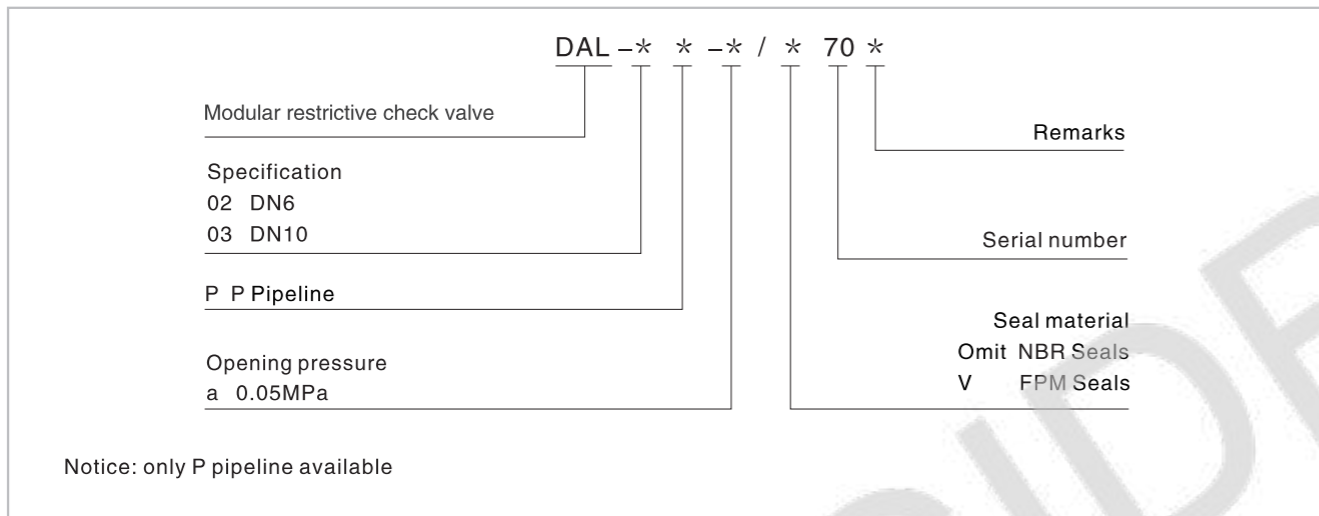

Code symbol

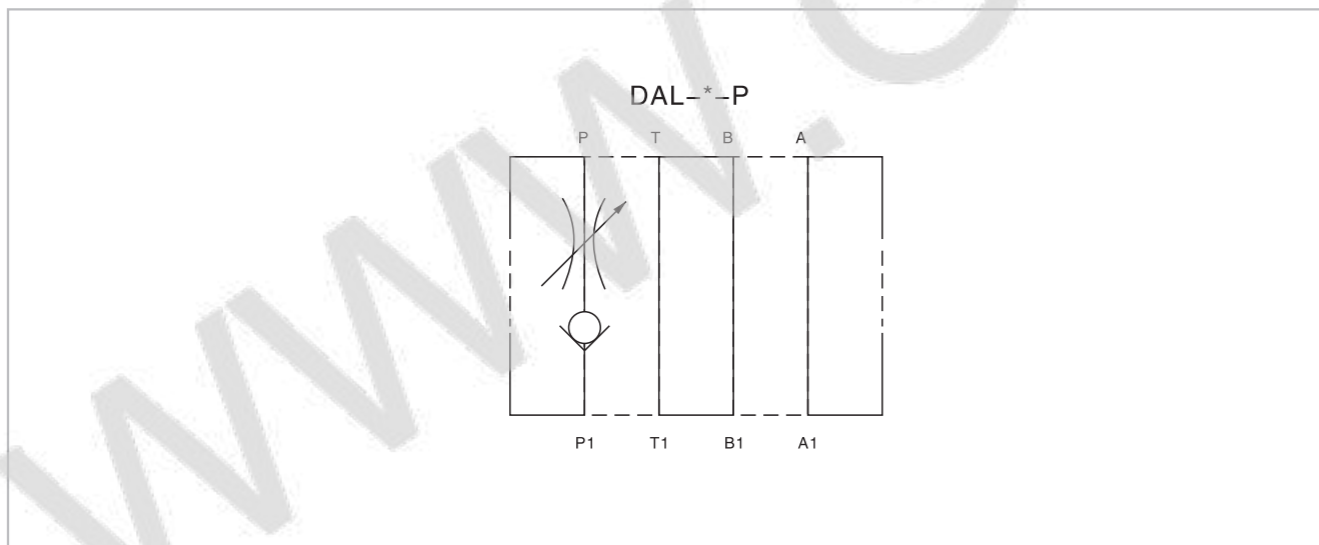

Modular Restrictive Check Valve

External dimensions

DAL-02-P ...

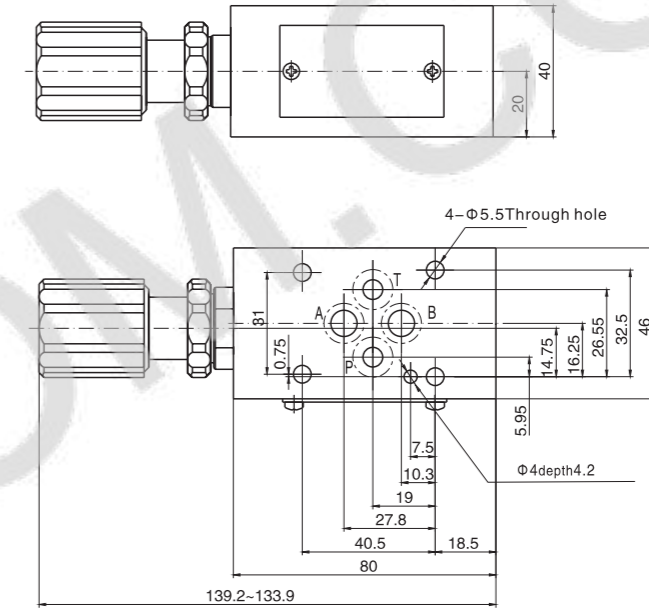

DAL-03-P ...

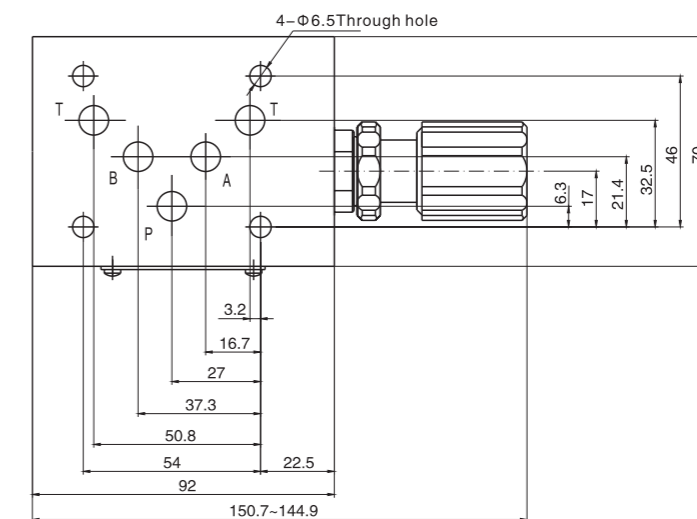
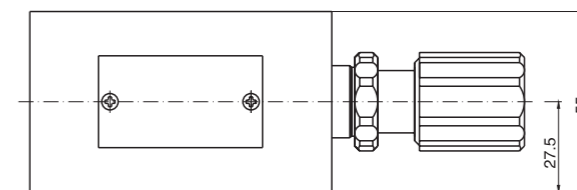

Notice: The surface, connecting with the valve, should be Ra0.8 roughness, and 0.01/100mm flatness.

Flow Control Valve

Technical data



Model	RUF-X 192AT	
Rated pressure (MPa)	31.5	
Min opening pressure (MPa)	2	
Max flow rate (L/min)	175	
Installation	Any	
Working fluid	Mineral oil, Phosphate	
Storage temp (°C)	-20~80	
Working temp (°C)	-10~60	
Cleanliness	NAS1638 Class 9, recommended filtration precision Min $\beta_{10} \geq 75$.	

Application:
pipeline type flow control valve is made of a restrictive valve and a check valve, used to adjust the flow rate.

Ordering code

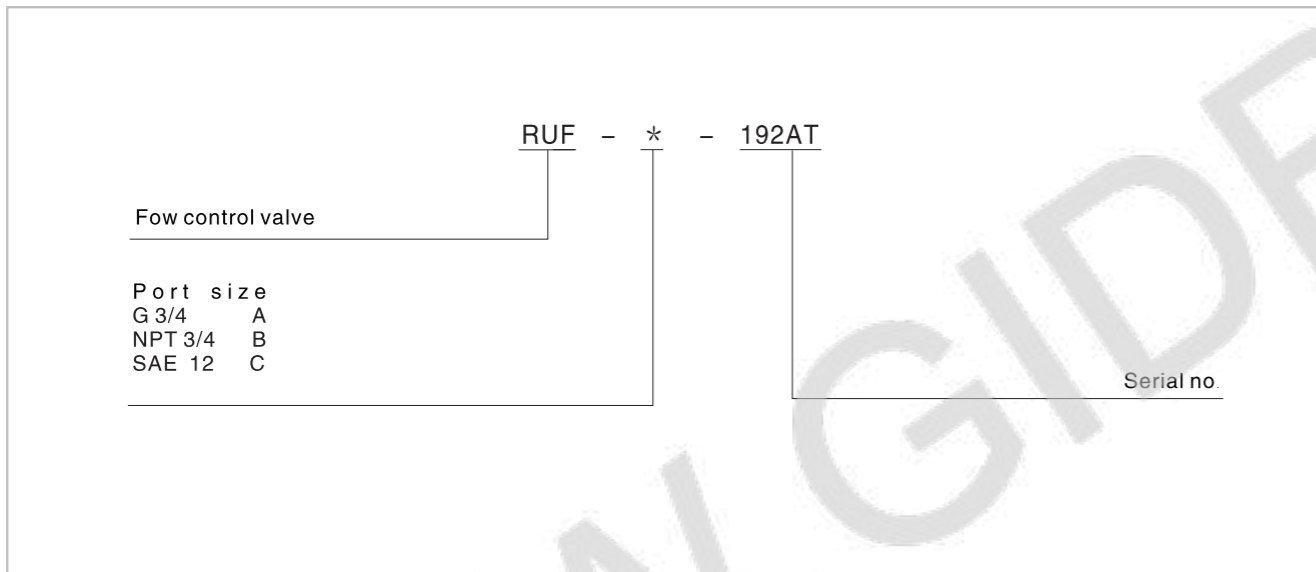

Hydraulic symbol

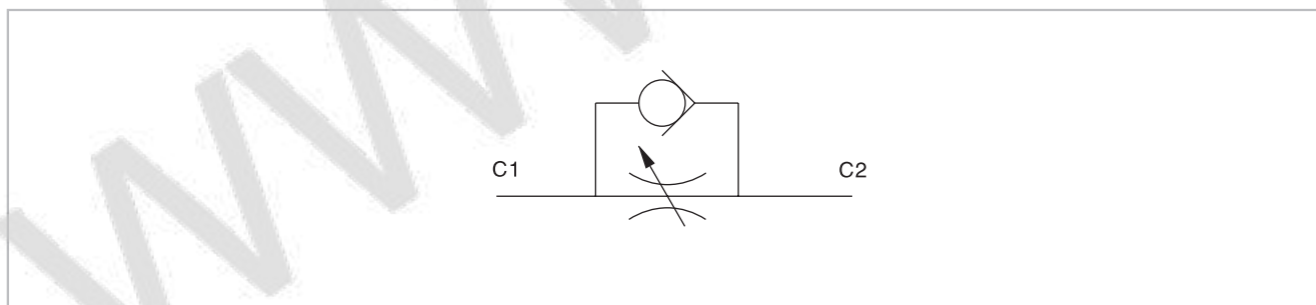

Fow Control Valve

Dimension

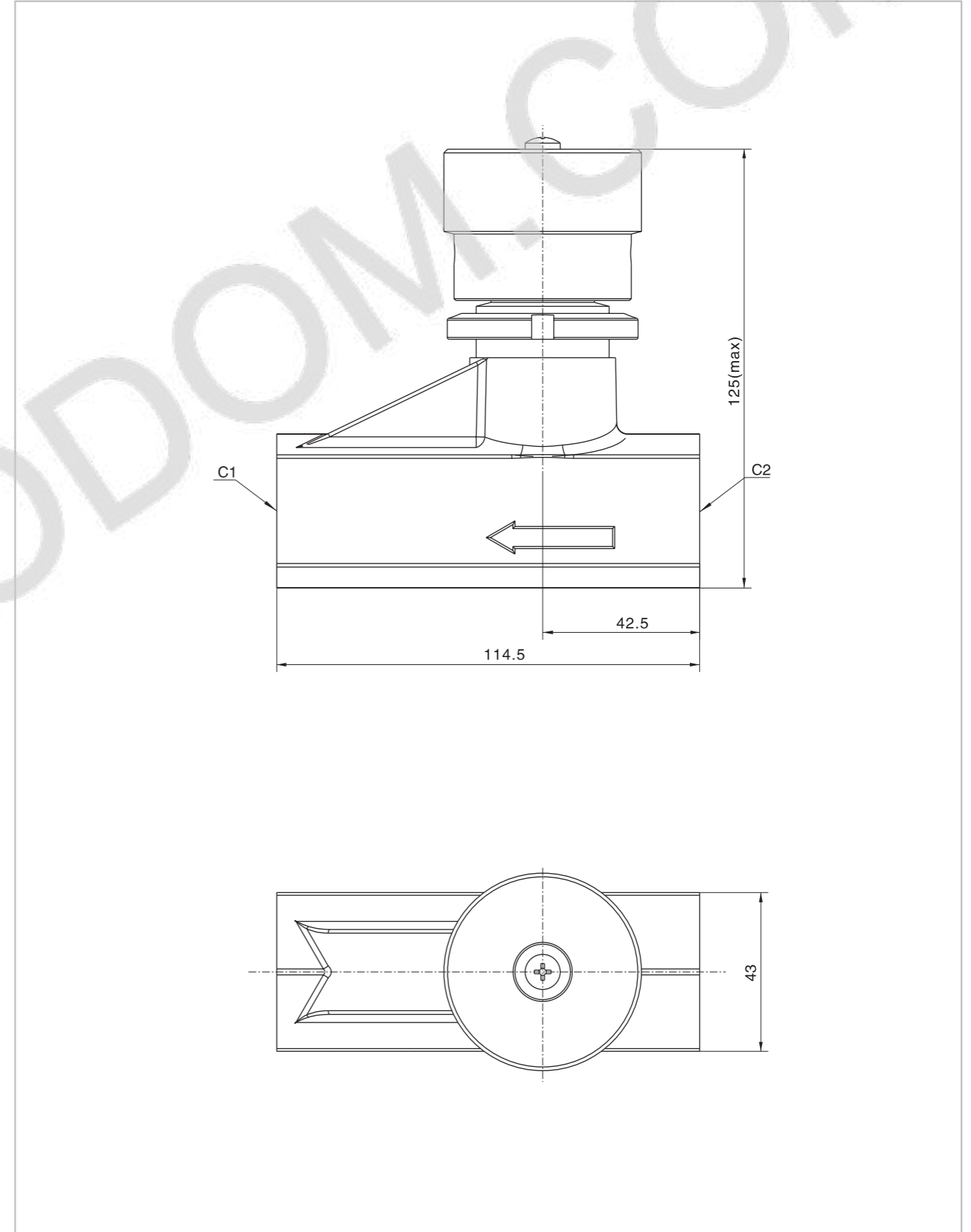

HOYEA

Directional Control Valves Series



WWW.GIDRODOM.COM

In-line Check Valve

Technical specification



Specification	02	03	04	06	10	12
Max. working pressure (MPa)	31.5					
Max. Flow (L/min)	30	50	140	220	320	430
Working fluid	Mineral oil;phosphate-ester					
Fluid temp. (°C)	-20~70					
Viscosity (mm ² /s)	2.8~380					
Opening pressure (MPa)	a0.05		b0.4			
Cleanliness	The maximum allowable cleanliness of the oil should be according to 9th degree of Standard NAS1638.It is suggested that the minimum filter rating should be $\beta_{10} \geq 75$.					

Check valve allows the fluid to flow only in one direction and prevents it from flowing in the opposite direction.

Check valve could be used at the outlet of hydraulic pressure pump to avoid the oil flow backwards. It can also separate the oil lines to avoid the oil lines mutual interference. It can be used as by-pass valve.

Model description

GA - * - * * / 5X *

In-Line check valve

Remarks

Serial number

SPECIFICATION

02 DN6
03 DN10
04 DN15
06 DN20
10 DND25
12 DN30

Opening pressure
a 0.05MPa
b 0.4MPa

Screw thread connector
Omit G Screw thread
M M Screw thread

In-line Check Valve

Code symbol

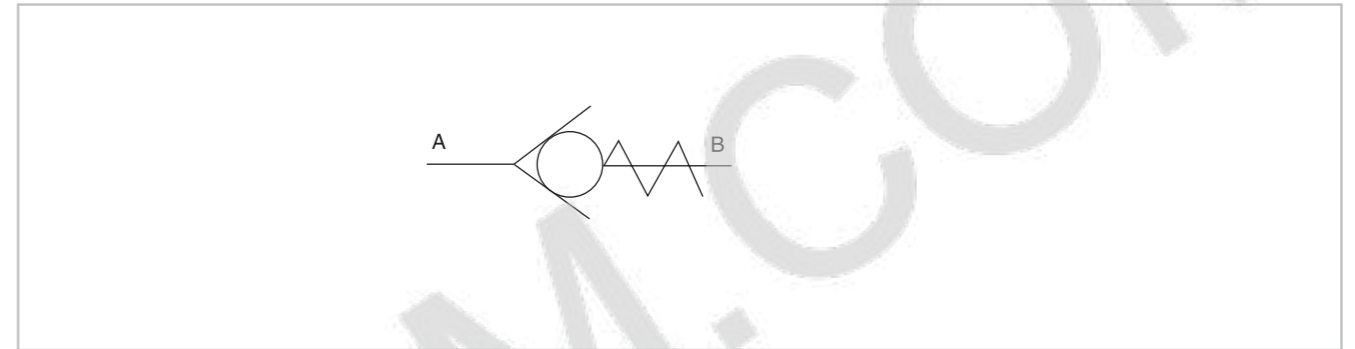

External dimensions

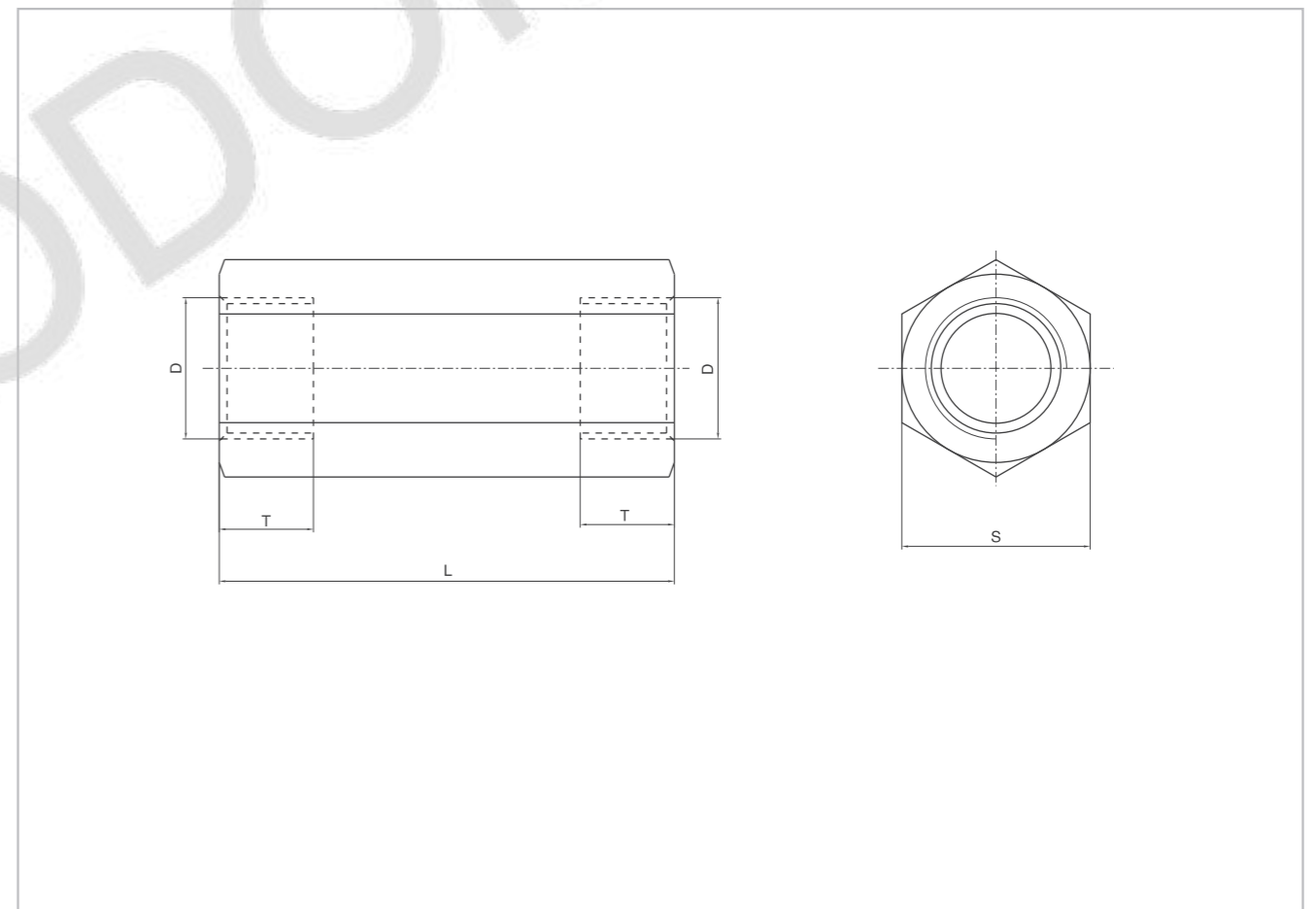

Specification	D		L(mm)	S(mm)	T(mm)
	British System	Metric System			
02	G3/8"	M18X1.5	58	24	12
03	G1/2"	M22X1.5	72	30	15
04	G3/4"	M27X2	85	36	17
06	G1"	M33X2	98	46	20
10	G1 1/4"	M42X2	120	60	22
12	G1 1/2"	M48X2	138	65	24

Orthogonal Check Valve

Technical specification



Specification	03	06	10
Max. working pressure (MPa)	31.5		
Max. Flow(L/min)	80	220	430
Working fluid	Mineral oil;phosphate-ester		
Fluid temp. (°C)	-20~70		
Viscosity (mm²/s)	2.8~380		
Opening pressure (MPa)	a0.05	b0.4	
Cleanliness	The maximum allowable cleanliness of the oil should be according to 9th degree of Standard NAS1638.It is suggested that the minimum filter rating should be $\beta_{10} \geq 75$.		

Check valve allows the fluid to flow only in one direction and prevents it from flowing in the opposite direction.

Check valve could be used at the outlet of hydraulic pressure pump to avoid the oil flow backwards. It can also separate the oil lines to avoid the oil lines mutual interference. It can be used as by-pass valve.

Model description

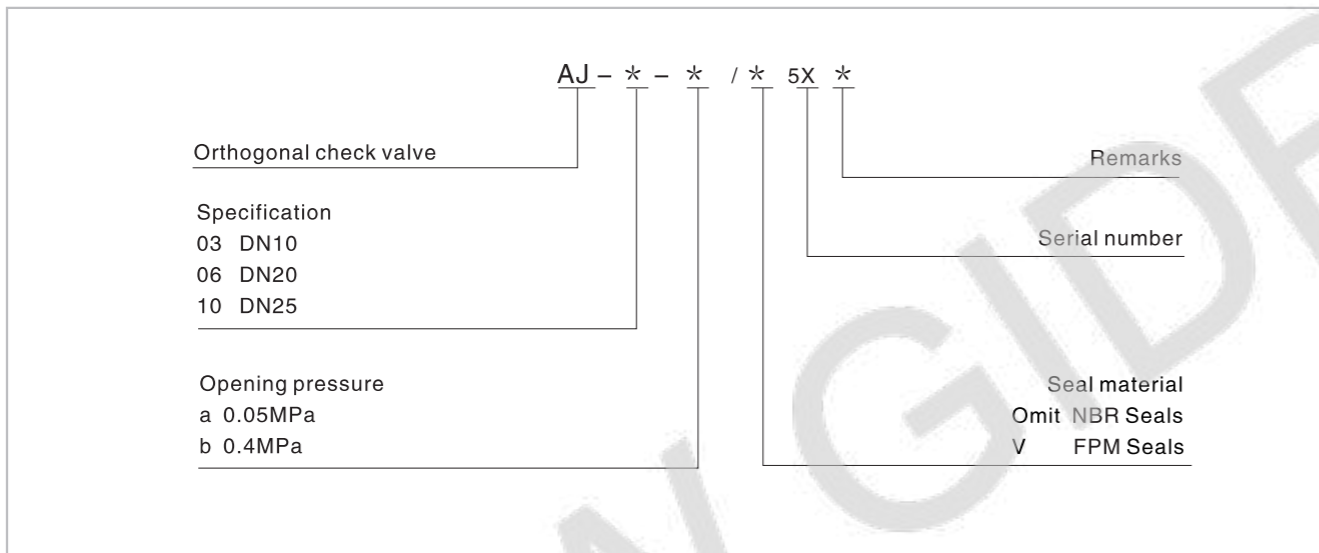

Code symbol

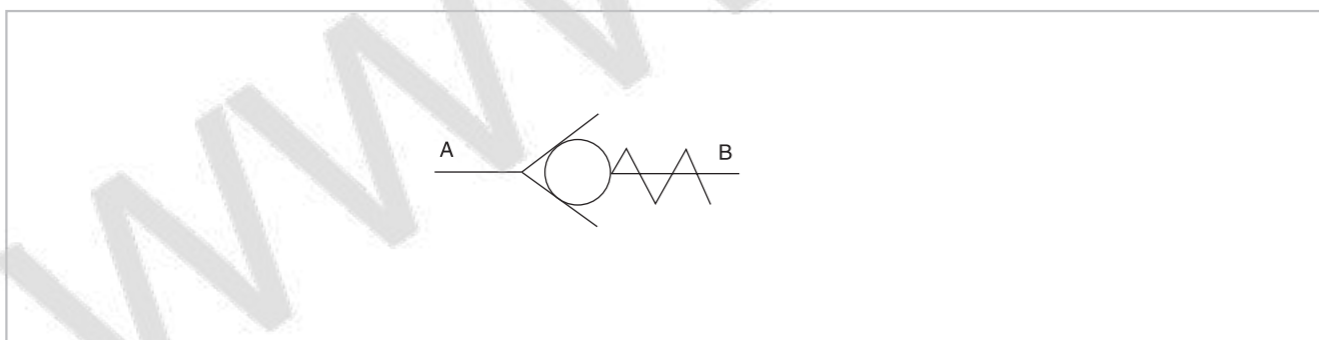

Orthogonal Check Valve

External dimensions

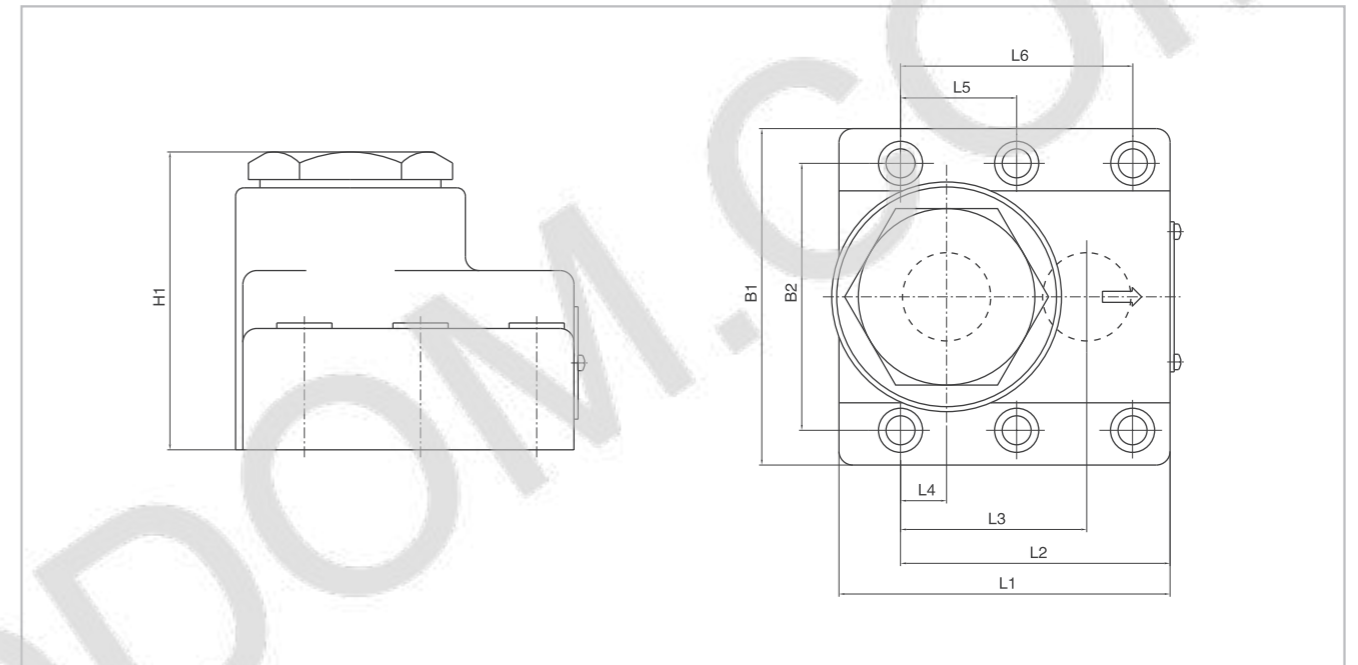

Size of subplate oil port

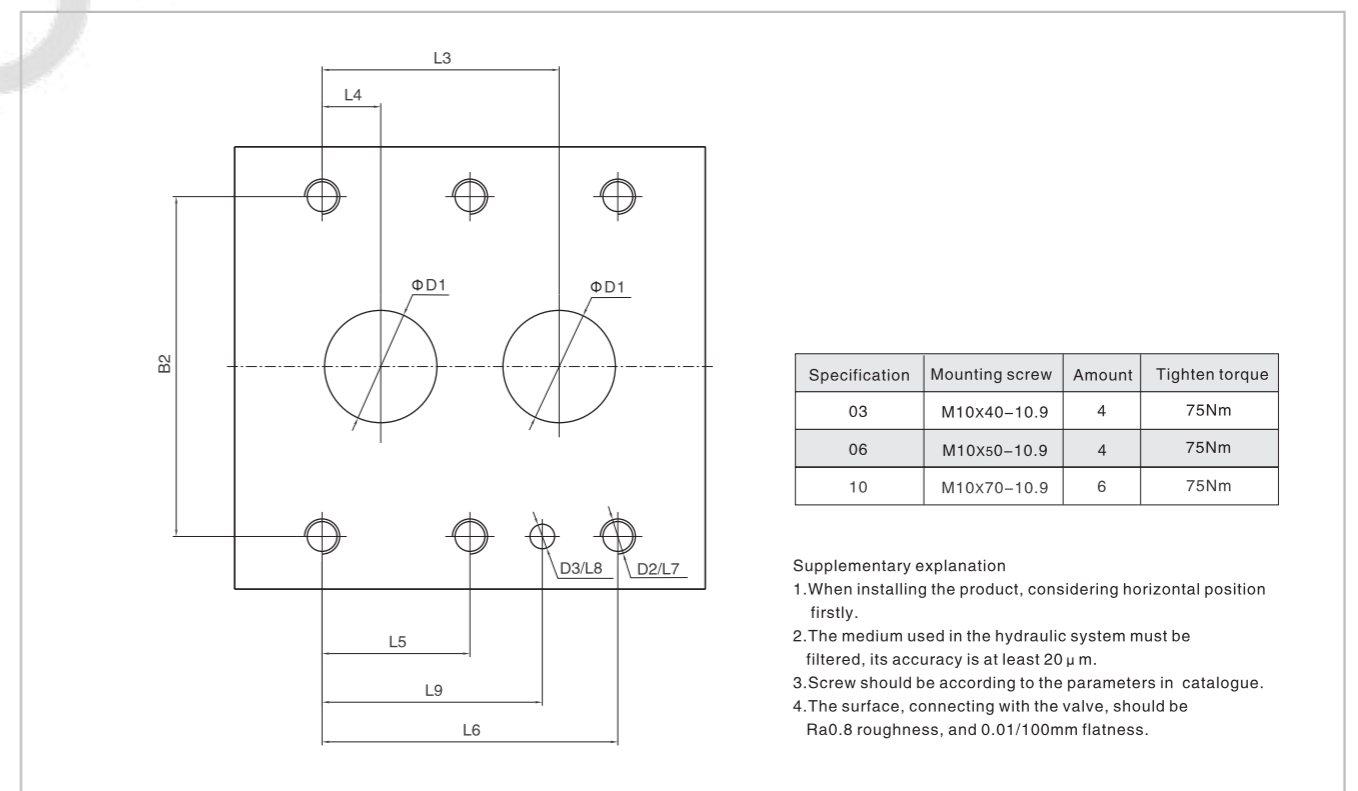

Specification	B1	B2	L1	L2	L3	L4	L5	L6	L7	L8	L9	D1	D2	D3	H1
03	90	66.7	67	55	35.8	7.25	-	42.9	23	6	31.8	13	M10	7	67
06	103.5	79.4	84.3	72.3	49.2	11.1	-	60.3	24	6	44.5	22	M10	7	79
10	122	96.8	112	98	67.5	16.7	42.1	84.2	25	6	62.7	32	M10	7	105

Hydraulic-operated Check Valve

Technical specification



Specification	03	06	10
Max. working pressure (Mpa)	31.5		
Control pressure (Mpa)	0.5~31.5		
Max. Flow (L/min)	100	350	550
Working fluid	Mineral oil; phosphate-ester		
Fluid temp. (°C)	-20~70		
Viscosity (mm ² /s)	2.8~380		
Opening pressure (Mpa)	a:0.15	b:0.3	c:0.6 d:1.0
Cleanliness	The maximum allowable cleanliness of the oil should be according to 9th degree of Standard NAS1638. It is suggested that the minimum filter rating should be β 10≥75.		

Hydraulic-operated check valve allows oil to flow in only one direction, and it can not allow the oil to flow in the opposite direction unless it uses the hydraulic control.

Hydraulic-operated check valve can be used as two way on-off valve, and also can be seen as a pressure retaining valve or a sustaining valve of the standing fluid cylinders.

Model description

Hydraulic-operated check valve
 AY - * * * - * / * 5X *

Remarks

Serial number

Seal material
 Omit NBR Seals
 V FPM Seals

Opening pressure
 a 0.15
 b 0.3
 c 0.6
 d 1.0

Plate connecting type	Pipe connecting type	Screw thread connector
03 NS10	10 DN10	G1/2" or M22x1.5
	15 DN15	G3/4" or M27x2
06 NS20	20 DN20	G1" or M33x2
	25 DN25	G1 1/4" or M42x2
10 NS30	30 DN30	G1 1/2" or M48x2

Omit Plate connecting type
 G Pipe connecting type-G Screw
 G2 Pipe connecting type-M Screw

A with unloading function
 B Without unloading function

Code symbol

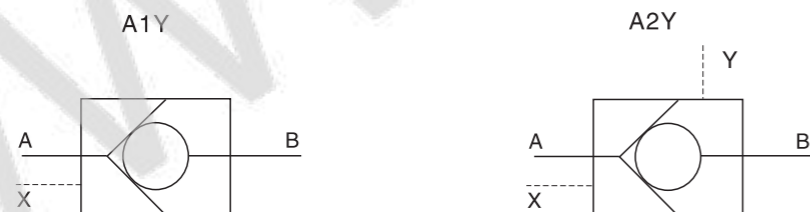

Hydraulic-operated Check Valve

External dimensions

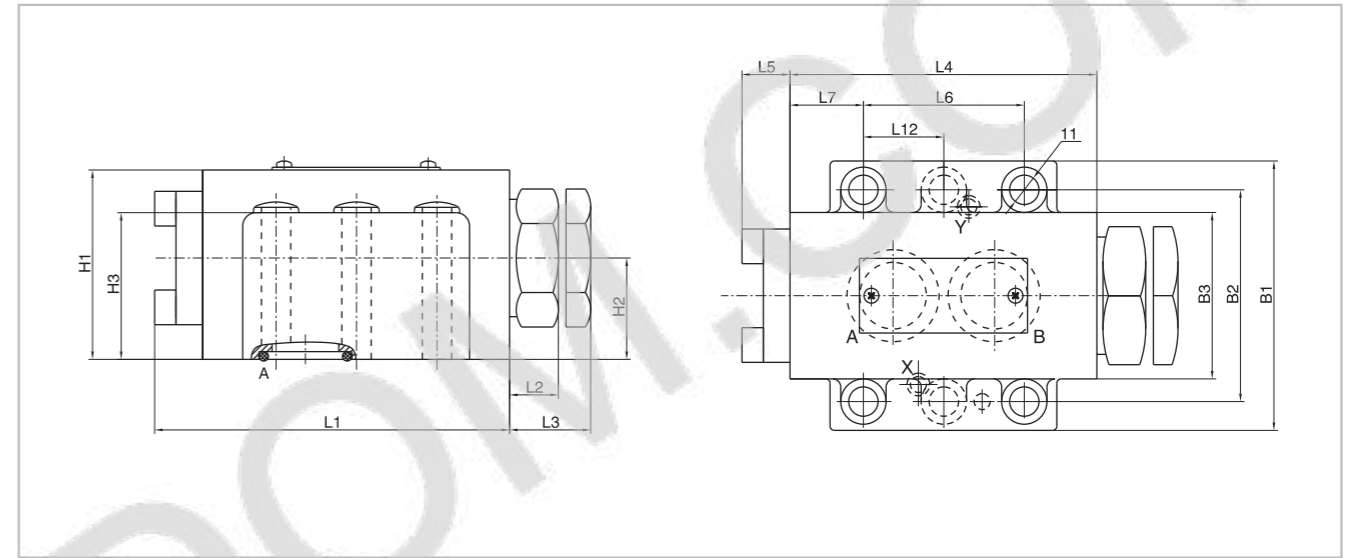

Size of subplate

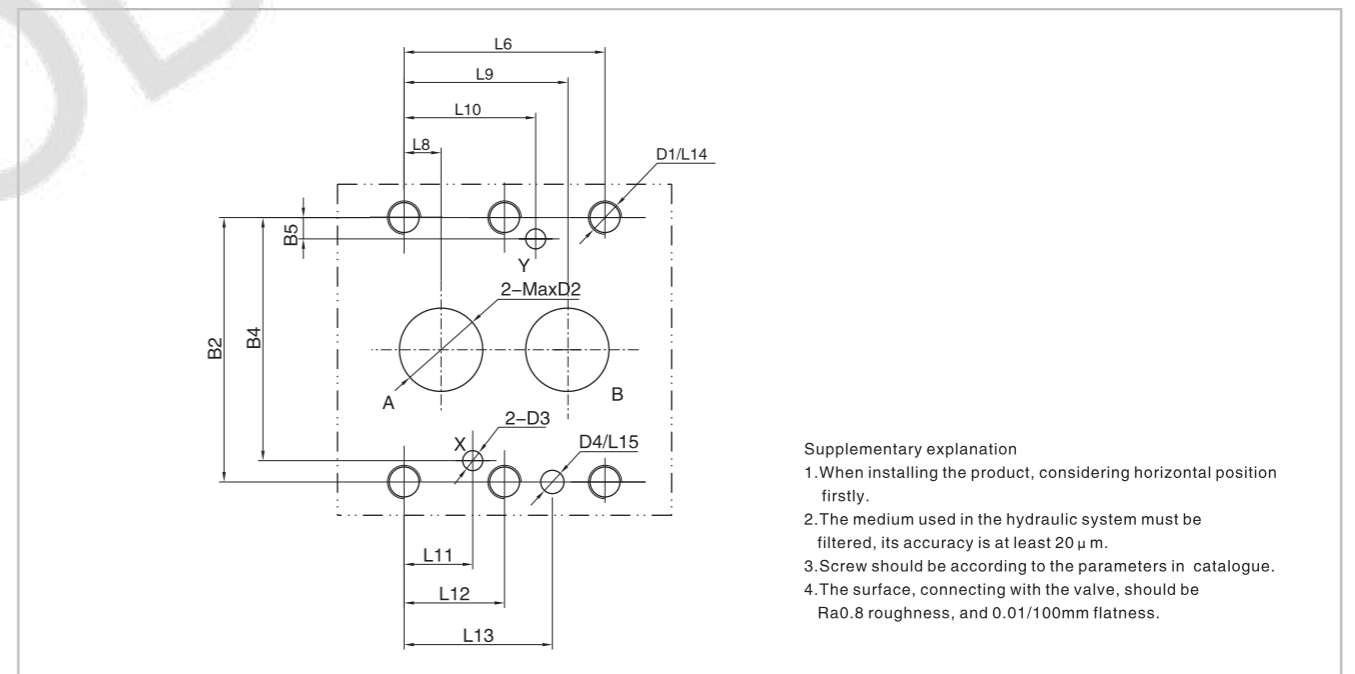

Model	Specification	L1	L2	L3	L4	L5	L6	L7	L8	L9	L10		L11	L12	L13	L14	L15
											A1Y	A2Y					
A1Y	03	102	14.3	15.5	89	13	42.9	18.5	7.2	35.8	-	21.5	21.5	-	31.8	23	6
	06	133	18.3	47.7	115	18	60.3	27.5	11.1	49.2	-	39.5	20.6	-	44.5	24	6
A2Y	10	156	35.6	46.1	134	22.1	84.2	39	16.7	67.5	-	42.1	24.6	42.1	62.7	25	6

Model	Specification	B1	B2	B3	B4	B5		H1	H2	H3	D1	D2	D3	D4
						A1Y	A2Y							
A1Y	03	84	66.7	44	58.8	-	7.9	51	29	36	M10	13	6	7
	06	101	79.4	62.4	73	-	6.4	71	38	55	M10	22	6	7
A2Y	10	117	96.8	77	92.8	-	3.8	85	42.5	70	M10	32	6	7

Prefill Valve

Technical specification



Specification		50	80
Max. working pressure (Mpa)	A	1.6	
	B	31.5	
	C	31.5	
	(L/min)	-	
Working fluid		Mineral oil; phosphate-ester	
	(°C)	-20~70	
Viscosity	(mm ² /s)	2.8~380	
	(MPa)	a:0.02	
Weight	(kg)	14	32
Cleanliness	The maximum allowable cleanliness of the oil should be according to 9th degree of Standard NAS1638. It is suggested that the minimum filter rating should be β 10≥75.		

Model description

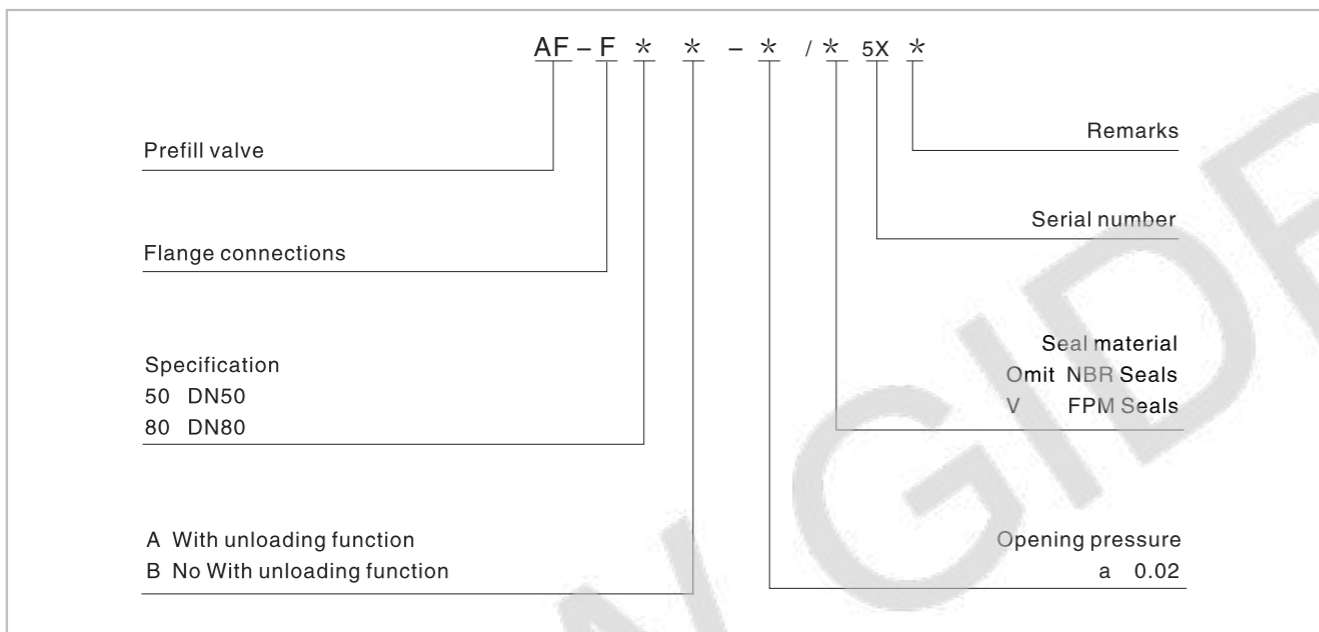

Code symbol

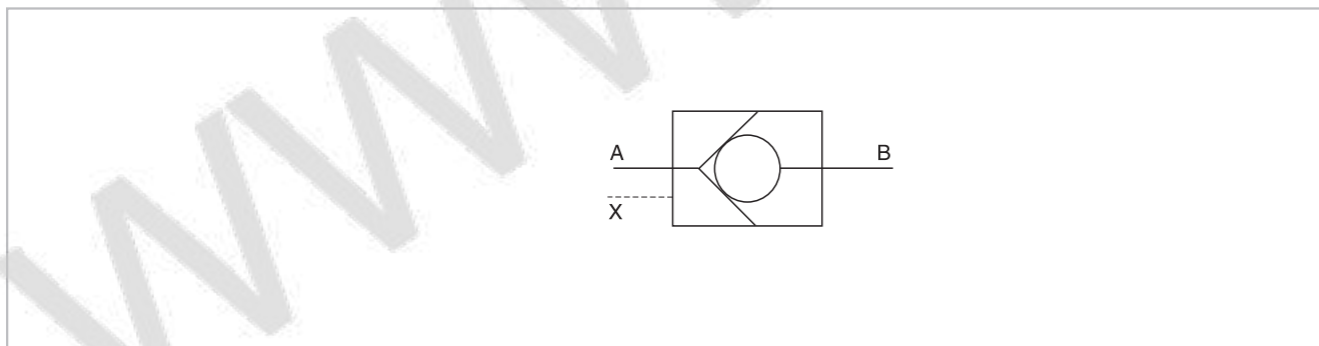

Prefill Valve

External dimensions

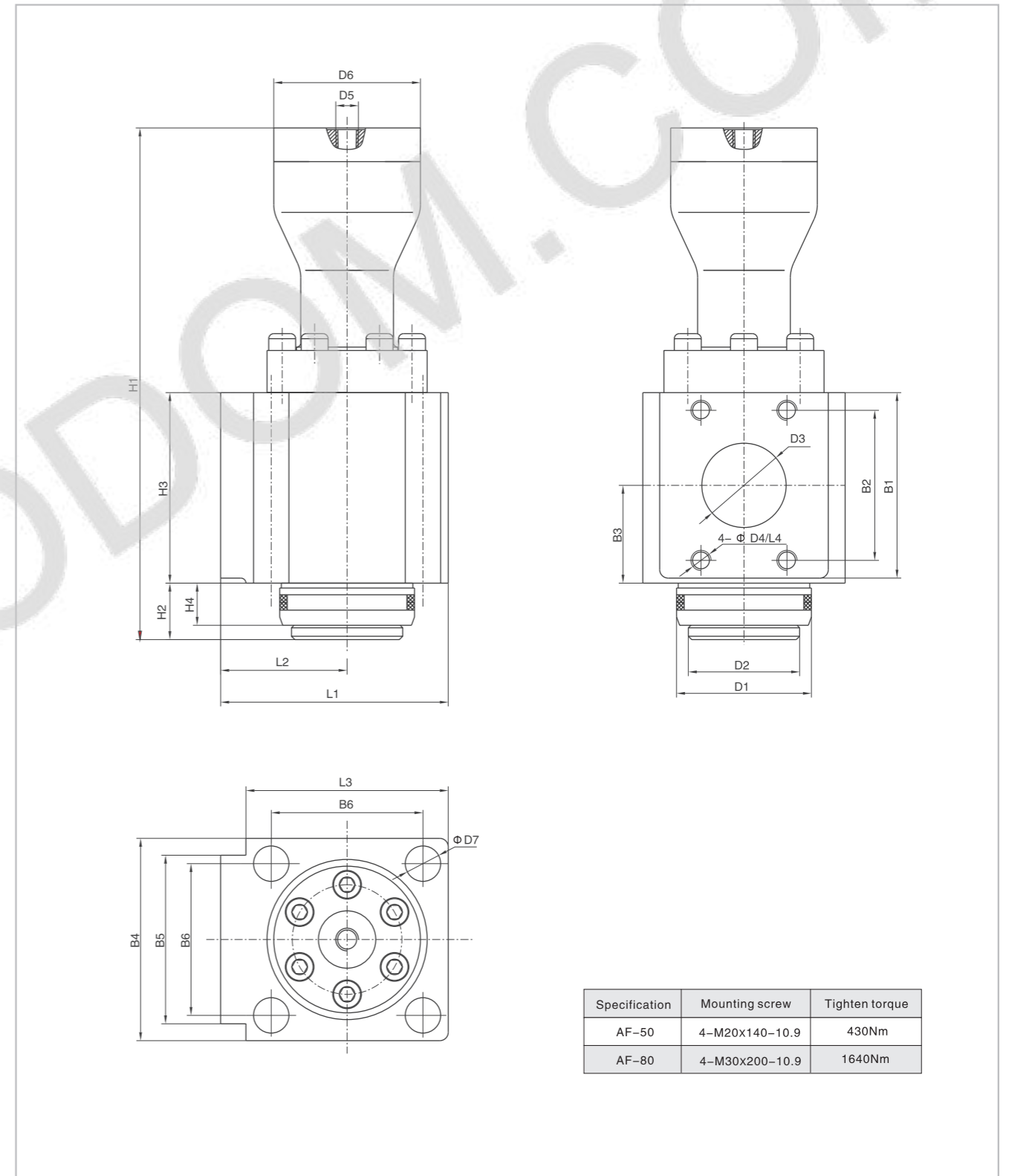

Specification	Mounting screw	Tighten torque
AF-50	4-M20x140-10.9	430Nm
AF-80	4-M30x200-10.9	1640Nm

Specification	L1	L2	L3	L4	B1	B2	B3	B4	B5	B6	H1	H2	H3	H4	D1	D2	D3	D4	D5	D6	D7
AF-50	135	75	120	16	110	89	58	120	100	90	303.5	33.5	113	25	80f7	66	50	M12	NPT / 4"	87	21
AF-80	192	102	180	20	157	106.5	77.5	180	115	130	357.5	40.5	160	30	115f7	97	76	M16	NPT / 4"	87	31

Electrical Operated Directional Control Valve

Technical specification



Specification		02	03
Working pressure (MPa)	Oil ports P,A,B	35	31.5
	Oil port T	10	10
Max. Flow (L/min)		80	120
Working fluid	Mineral oil; phosphate-ester		
Fluid temp. (°C)	-20~70		
Viscosity (mm ² /s)	2.8~100		
Working voltage (V)	DC	12	24
	AC	110/50Hz	220/50Hz
Max. Switch frequency (T/h)		15000 (DC)	7200 (AC)
Insulation grade	IP65		
Weight (kg)	Single solenoid	1.45(DC) 1.4(AC)	5.1(DC) 4.3(AC)
	Double solenoids	1.95(DC) 1.9(AC)	6.7(DC) 5.1(AC)
Cleanliness	The maximum allowable cleanliness of the oil should be according to 9th degree of Standard NAS1638. It is suggested that the minimum filter rating should be β ₁₀ ≥ 75.		

Model description

Electrical Operated Directional Control Valve

Specification
02 DN6
03 DN10

Function code
Details as following symbol table

Working voltage
D12 DC12V
D24 DC24V
A110 AC110V
A220 AC220V
B110 AC110V Rectified
B220 AC220V Rectified

Z5L Square connector with light
Z6 Wire box type

Remarks

Serial number

50
60
70

Seal material
Omit NBR Seals
V FPM Seals

Omit without damping
08 Φ0.8 Damping
10 Φ1.0 Damping
12 Φ1.2 Damping

Omit without hand emergency
N9 with concealed hand emergency

FW - * - * - * - * - * / * * 5X *

Electrical Operated Directional Control Valve

Code symbol

Spring return

3C2		2B2B		2B2BL		2B2	
3C3		2B3B		2B3BL		2B3	
3C4		2B4B		2B4BL		2B8	
3C5		2B5B		2B5BL		2B2L	
3C6		2B6B		2B6BL		2B3L	
3C7		2B7B		2B7BL		2B8L	
3C9		2B9B		2B9BL		With detent	
3C10		2B10B		2B10BL			2D2
3C11		2B11B		2B11BL			2D3
3C12		2B12B		2B12BL			2D8
3C25		2B25B		2B25BL		No spring return and no detent mechanical positioning	
3C29		2B29B		2B29BL			2N2
							2N3
							2N8

Note: *D* (No spring return mechanical positioning) solenoid directional control valve should be installed horizontally.

Electrical Operated Directional Control Valve

Name of solenoid

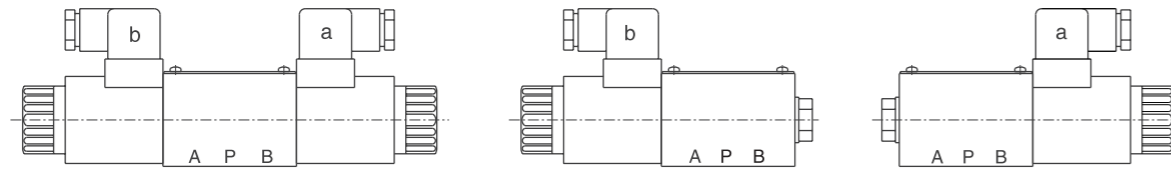

1. a When movement a, P→A B→T
2. b When movement b, P→B A→T
3. Oil flow in the opposite direction with the above-mentioned movement for 3C5、3C6symbol Valve.

02 Specification Performance curve (Measured at $v=41\text{mm}^2/\text{s}$ and $t=50^\circ\text{C}$)

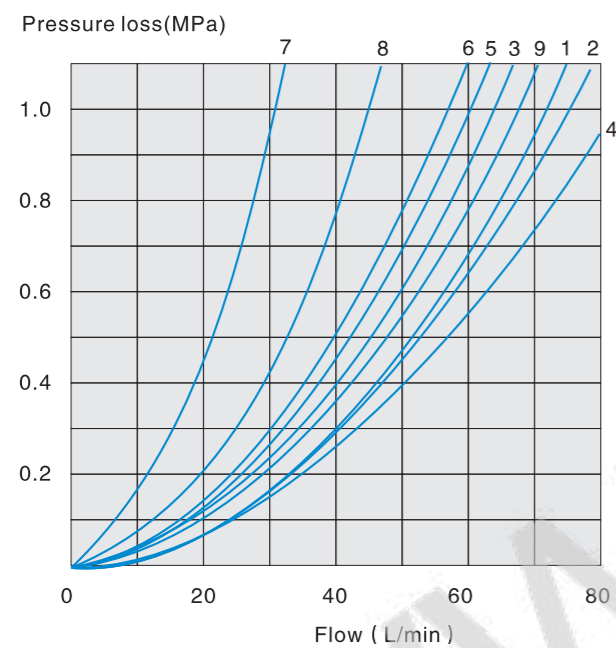

Function code	Direction			
	P→A	P→B	A→T	B→T
2B8 2B8L	3	3	-	-
2B3	1	1	3	1
2B2 2B2L	5	5	3	3
3C2	3	3	1	1
3C5	1	3	1	1
3C6	6	6	9	9
3C3	2	4	2	2
3C4	1	1	2	1
3C10,3C12	3	3	4	9
3C9	2	3	3	3
3C25	3	1	1	1
3C29	5	5	4	-
3C7	1	2	1	1

7. Spool type "3C29" located in the control position A→B
8. Spool symbol 3C6 in the neutral position P→T

Electrical Operated Directional Control Valve

02 Specification Working limits (The working limits for directional valves have determined by using solenoids at their operating temperature, 10% under voltage and with no pre-loading of the tank)

With regard to the four-way valve, the normal flow data as shown is get from the regular use of two directions of the flow (e.g.P to A, and simultaneous return flow from B to T). See tables. If only one flow direction is needed, for example: When a four port valve which is closed up port A or port B, used as a three-way valve, the Maximum flow may be very small in the serious condition.

DC solenoid operation DC D24, D1 2, B220, B110		AC solenoid operation AC A110, A220, 50HZ	
Curve	Symbol	Curve	Symbol
1	2B8 2B8L 1)	11	
2	3C7	12	
3	2B8 2B8L	13	
4	3C5 3C25	14	
5	3C4	15	
6	3C6 3C3	16	
7	2N8 2D8 3C10 3C12	17	
8	2B3 2B2 2B2L		2B8 2B8L 1)
9	3C9		3C7
10	3C2 3C29 2N3	18	2B8 2B8L
	2D3 2N2 2D2		3C5 3C25
			3C6
			3C3
			2N8 2D8 2N3 2D3
			2N2 2D2 3C2 3C4 3C10
			3C9 3C29 3C12
			2B3 2B2 2B2L

Working pressure(MPa)

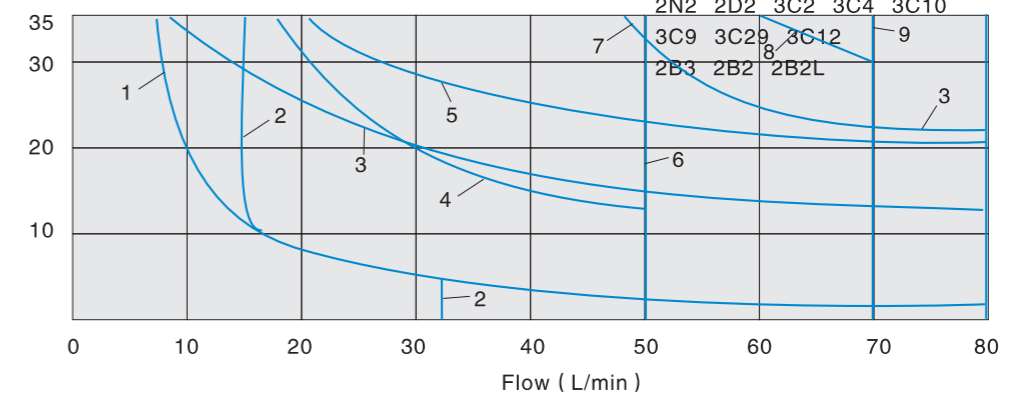

- 1) No manual emergency operation
- 2) Oil return from actuator to oil tank

Working pressure(MPa)

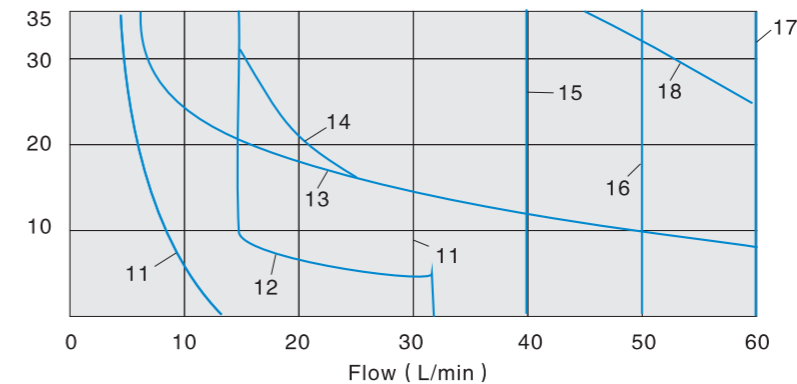

Electrical Operated Directional Control Valve

03 Specification Performance curve (Measured at $v=41\text{mm}^2/\text{s}$ and $t=50^\circ\text{C}$)

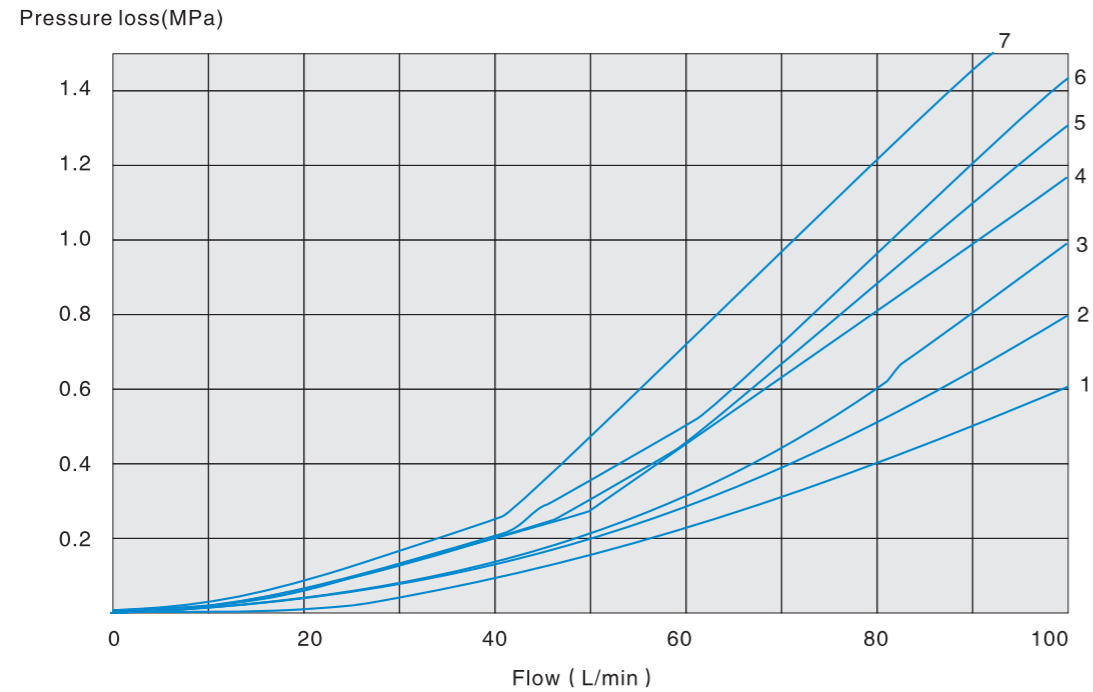

Function code	Direction			
	P→A	P→B	A→T	B→T
2B8 2B8L	2	2	-	-
2B3 2B2 2B2L	2	2	3	3
3C2 3C7	2	2	4	4
3C5	2	3	3	5
3C6	3	3	4	6
3C3	1	1	4	5
3C10 3C12	2	2	3	5
3C9	1	1	5	1
3C25	3	2	5	3
3C29	2	4	3	-

7. Spool symbol "3C29" in the shifting position A → B
 4. Spool symbol 3C6 in neutral position P → T

Electrical Operated Directional Control Valve

03 Specification Working limits (The working limits for directional valves have determined by using solenoids at their operating temperature, 10% under voltage and with no pre-loading of the tank)

With regard to the four-way valve, the normal flow data as shown is get from the regular use of two directions of the flow (e.g.P to A, and simultaneous return flow from B to T). See tables. If only one flow direction is needed, for example: When a four port valve which is closed up port A or port B, used as a three-way valve, the Maximum flow may be very small in the serious condition.

Working pressure(MPa) DC solenoid operation

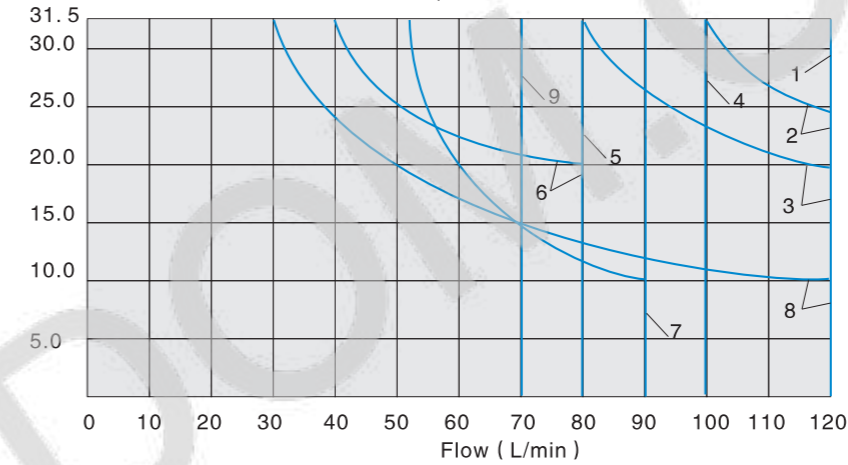

Curve	Symbol
1	2B3 2N3 2D3 2B2 2N2 2D2 2B2L 3C9
2	3C2
3	2N8 2D8 3C10 3C12 3C4
4	3C3
5	3C29
6	3C6
7	3C5 3C25
8	2B8 2B8L
9	3C7
1)	Return circuit (Independent of area ratio)

Working pressure(MPa) AC solenoid operation

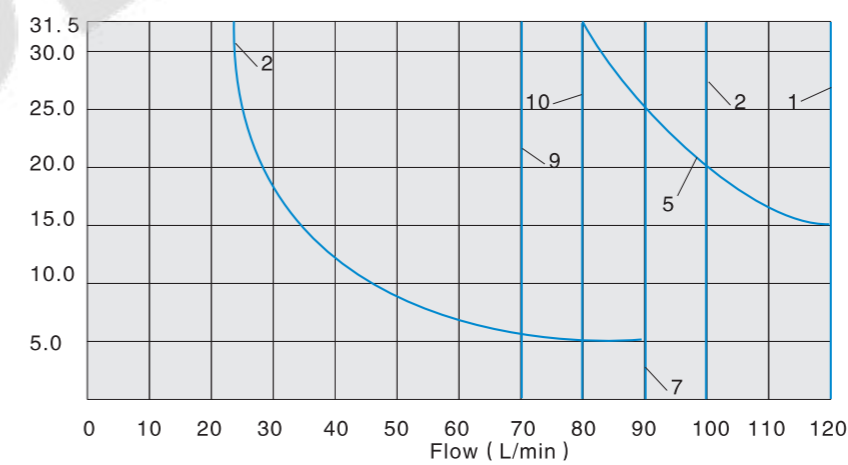

110V,50Hz; 120V,60Hz; 220V,50Hz; 240V,60Hz;	
Curve	Symbol
1	2B3 2N3 2D3 2B2 2N2 2D2 2B2L
2	3C2 3C10
3	3C12 3C9
4	2B8 2B8L
5	2N8 2D8 3C4
6	3C6
7	3C5 3C25
8	3C7
9	3C3
10	3C29

Working pressure(MPa) AC solenoid operation

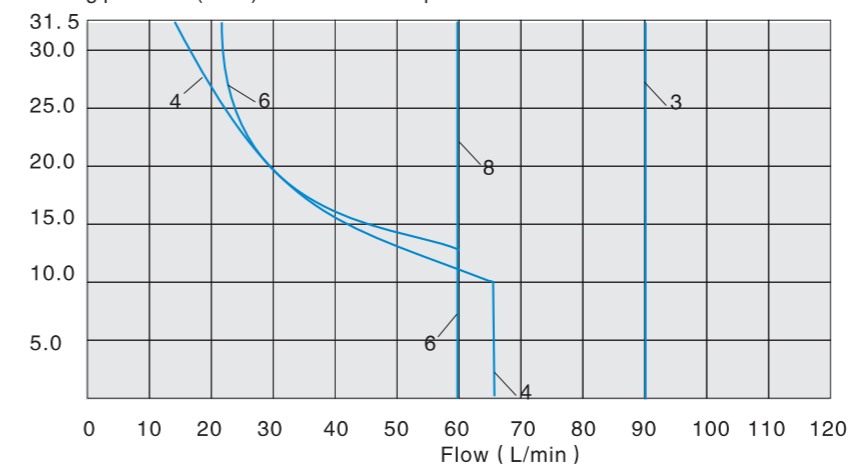

Electrical Operated Directional Control Valve

External dimensions (02 Direct current plug type)

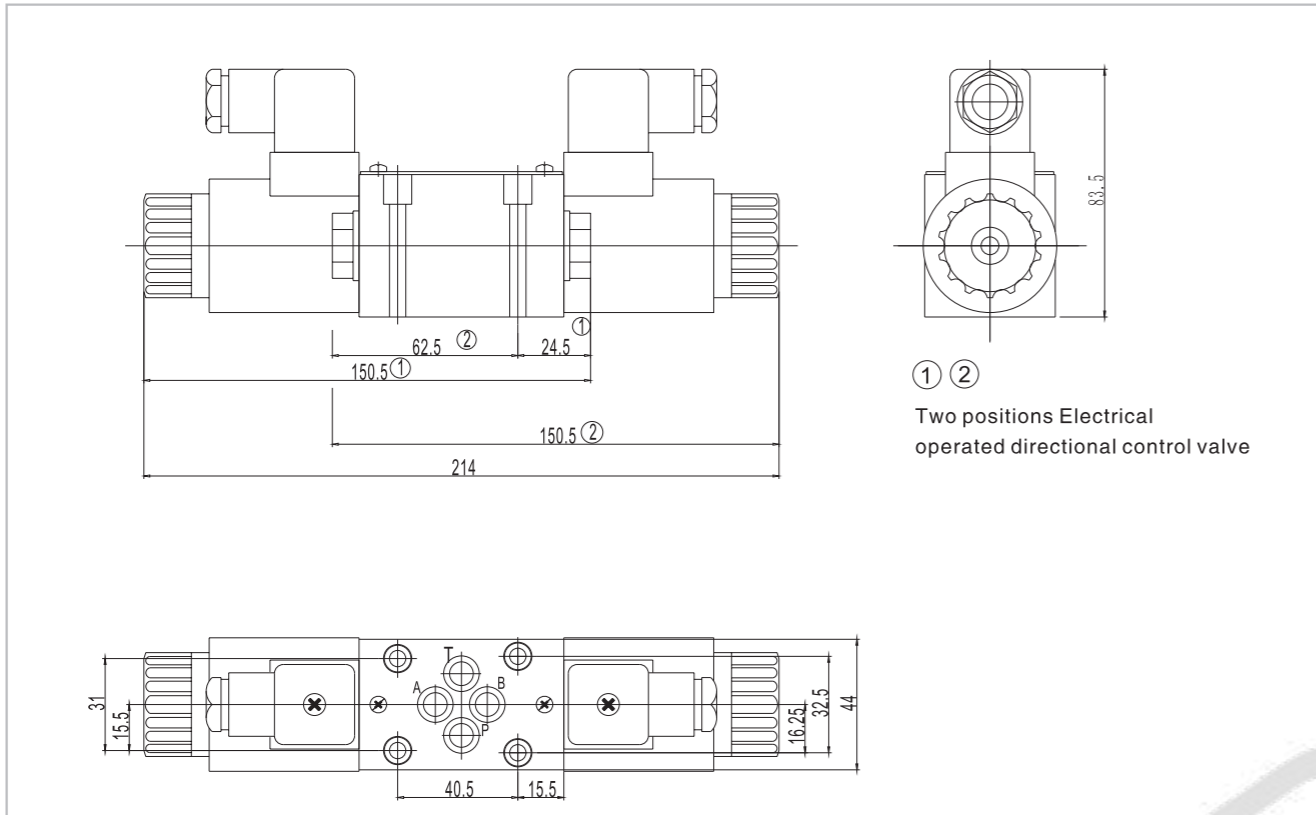

Electrical Operated Directional Control Valve

External dimensions (02 Alternating current plug type)

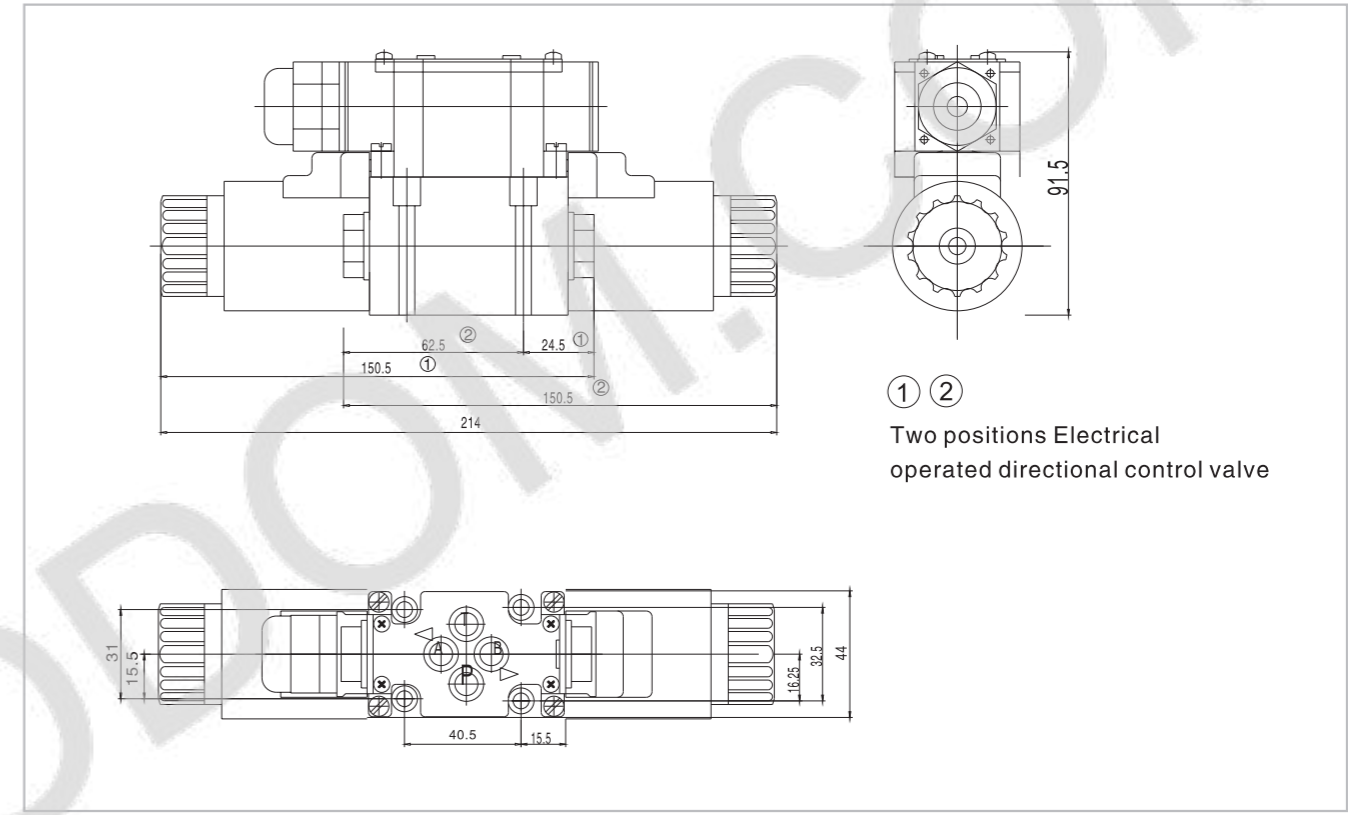

External dimensions (02 Direct current wire box type)

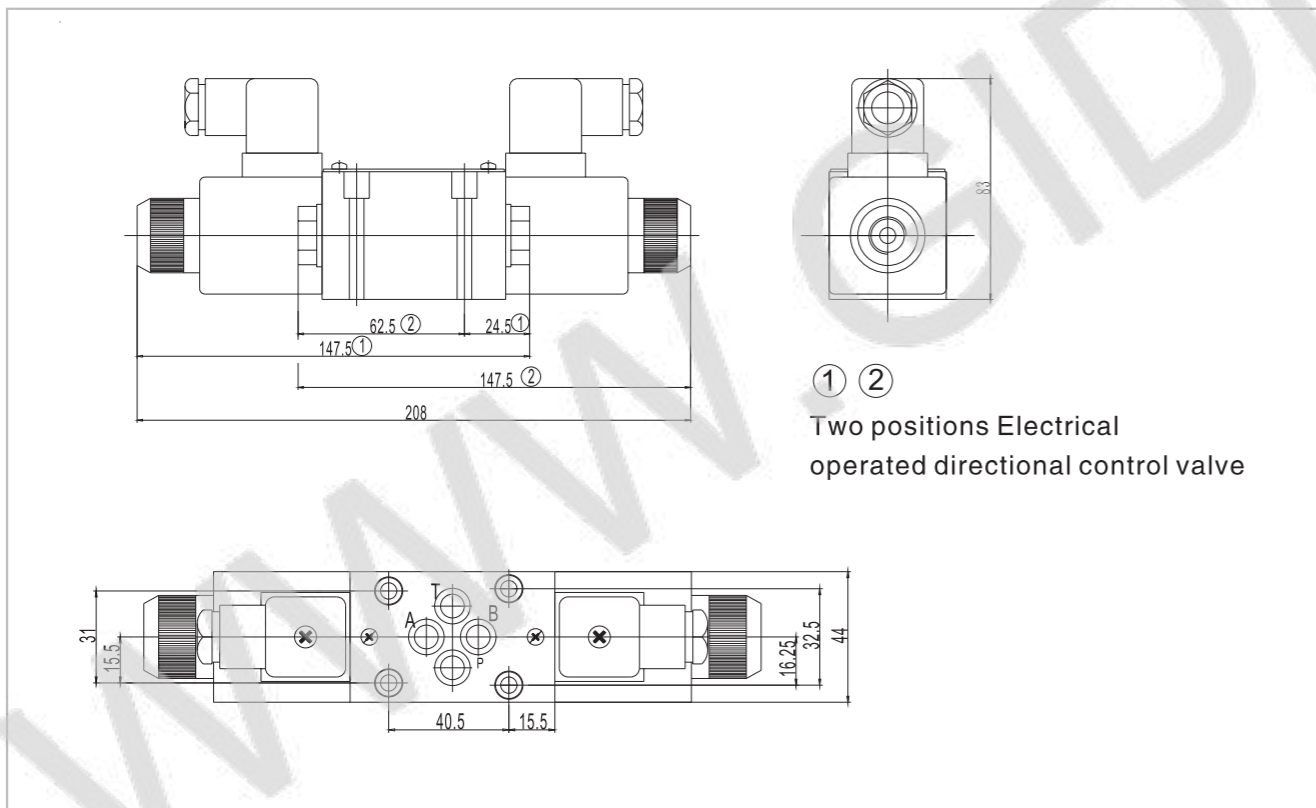

External dimensions (02 Alternating current wire box type)

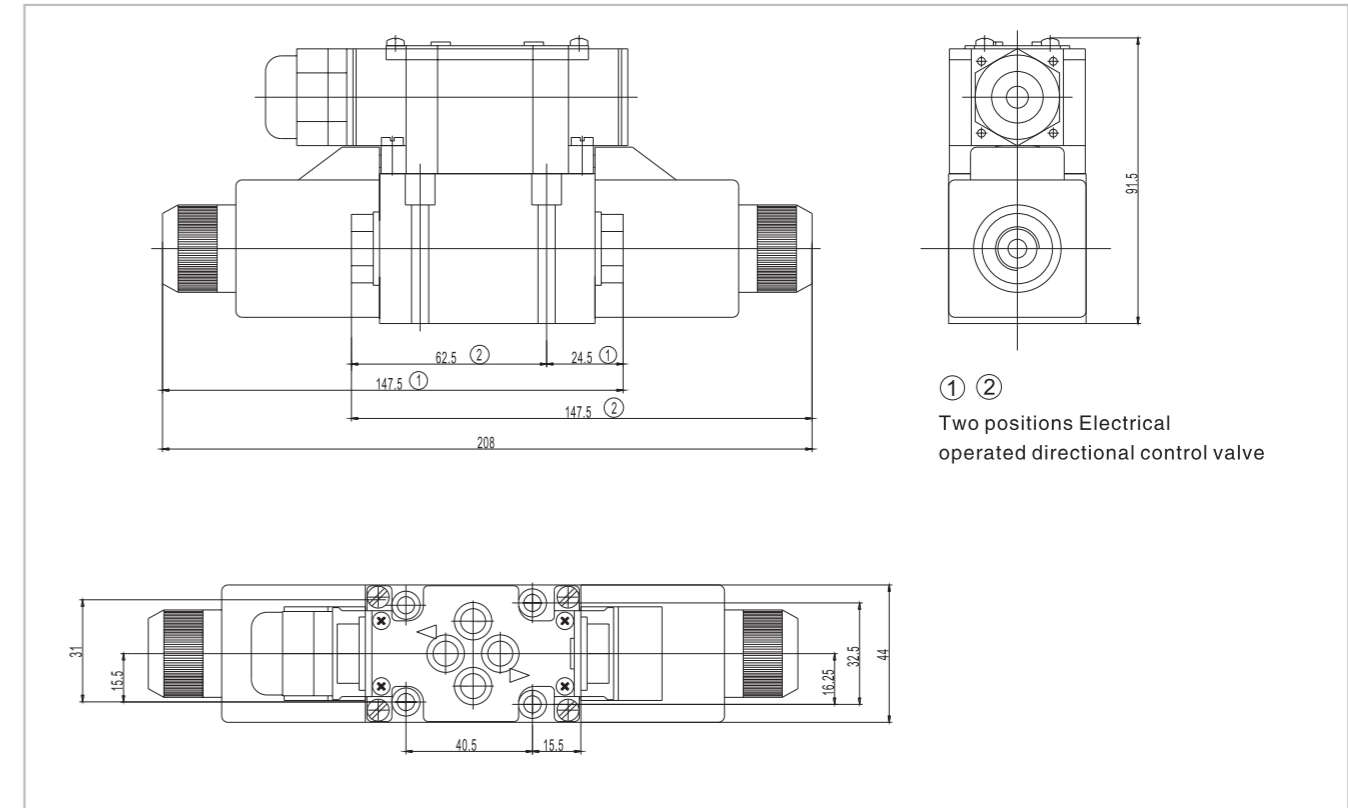

Electrical Operated Directional Control Valve

02 Size of subplate oil port

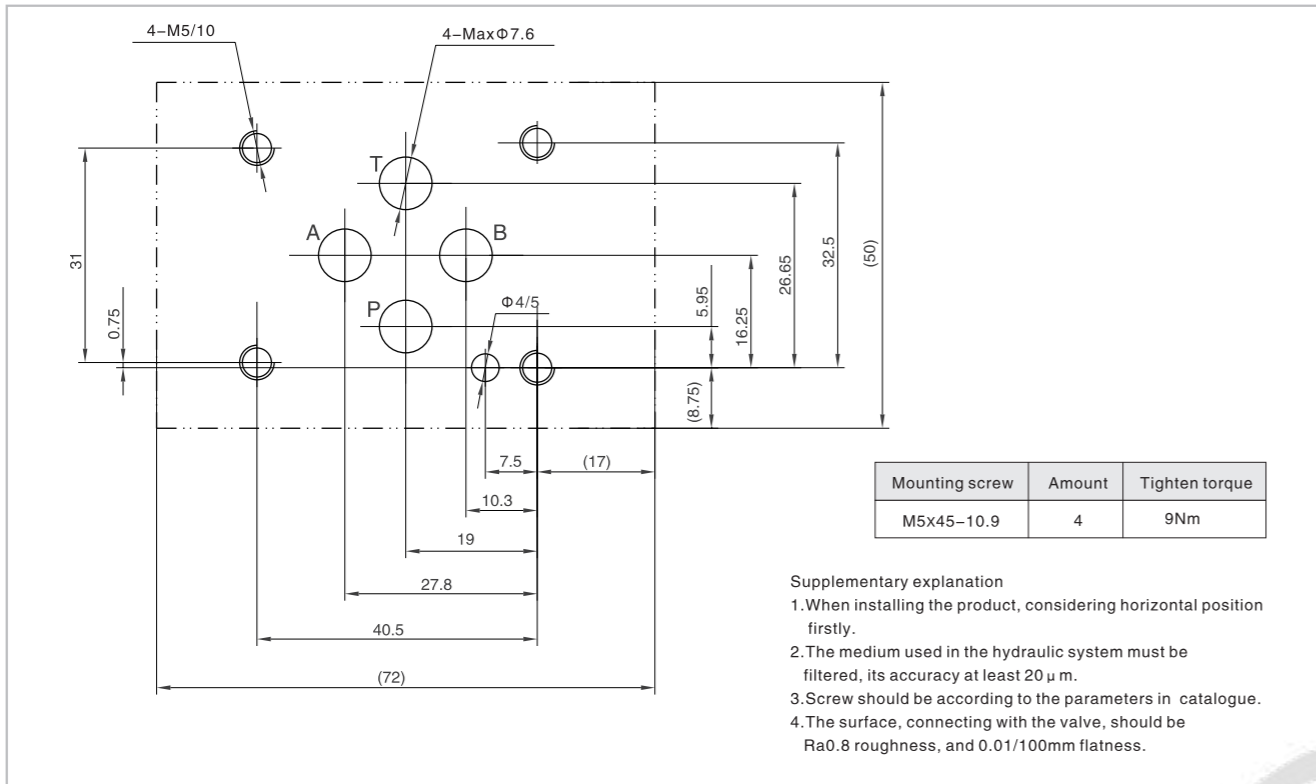

Electrical Operated Directional Control Valve

External dimensions (03 Alternating current plug type)

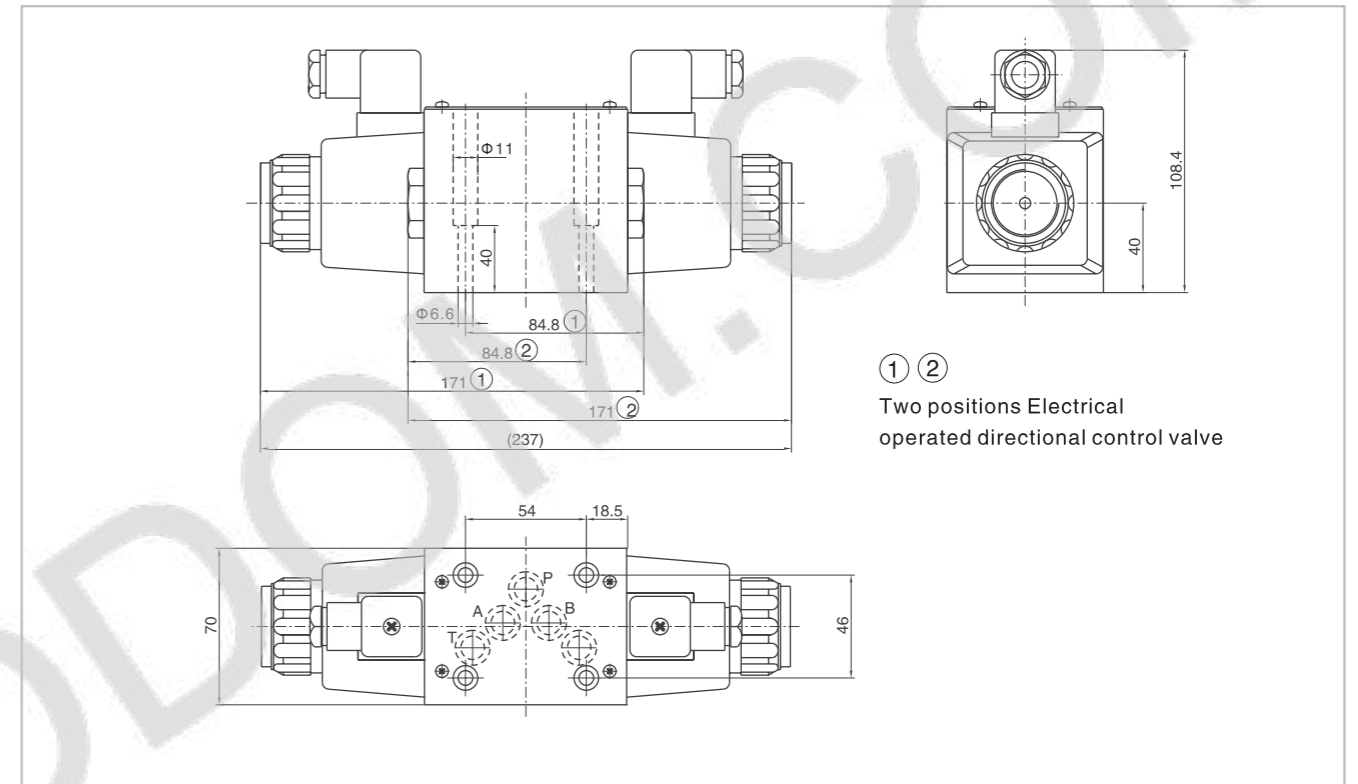

External dimensions (03 Direct current plug type)

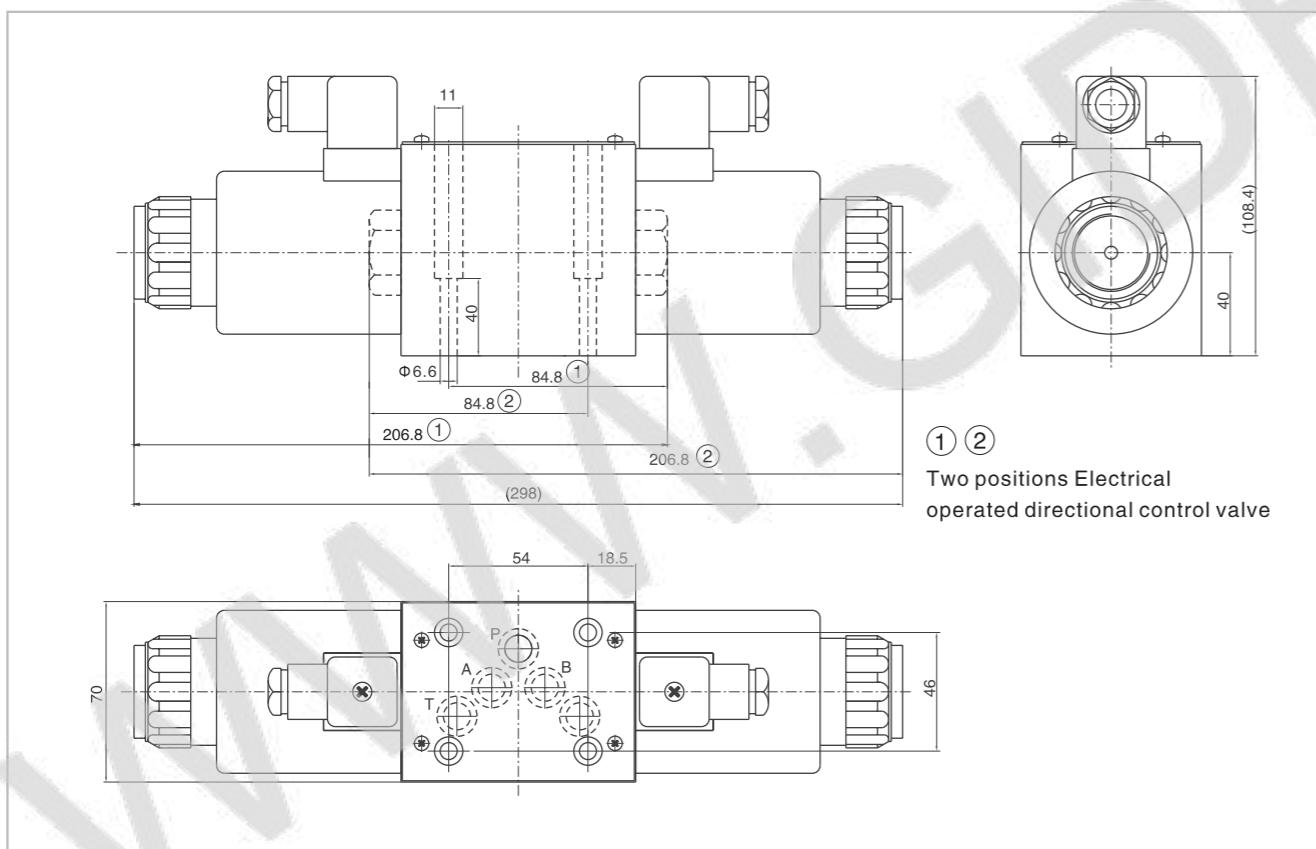

03 Size of subplate oil port

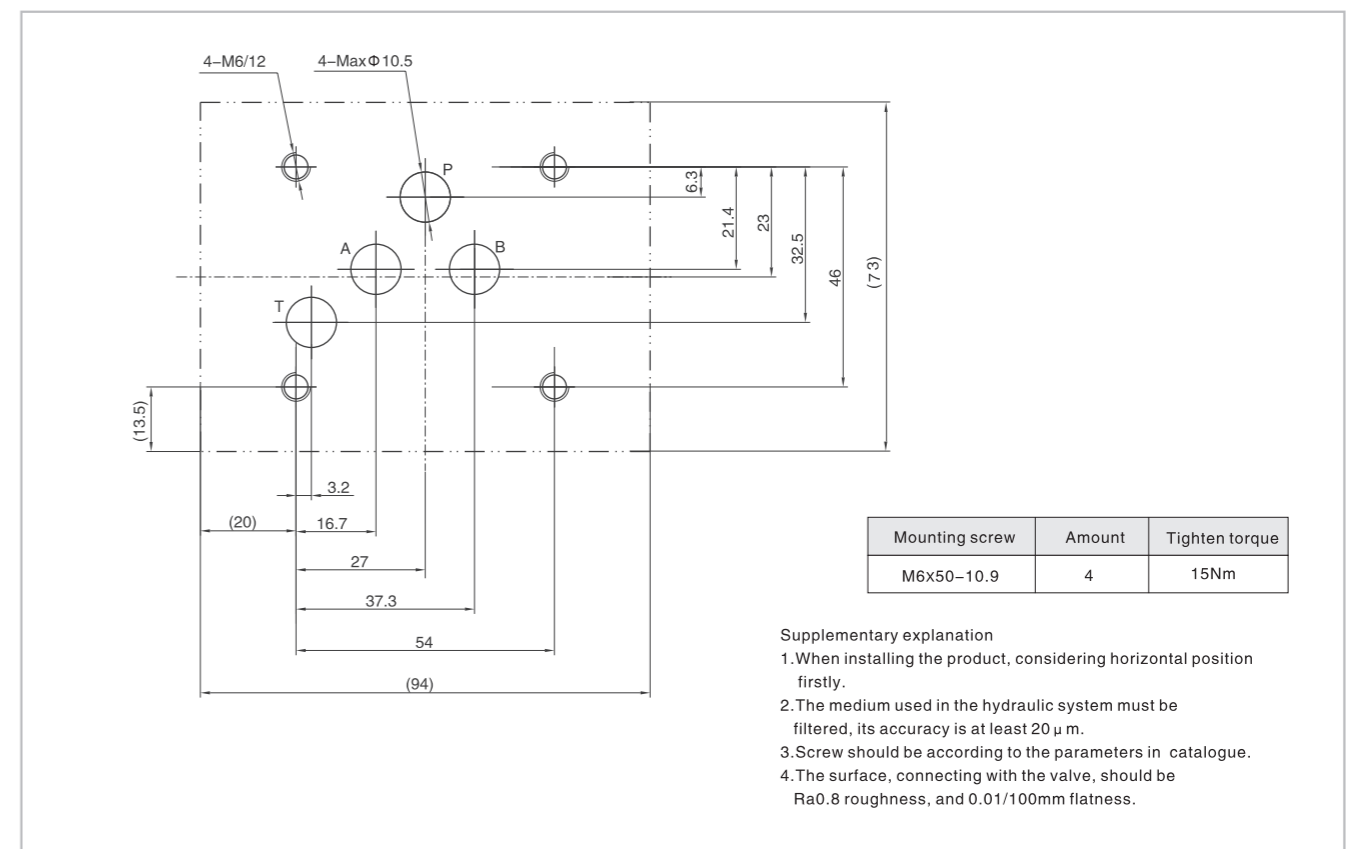

Electro-hydraulic Directional Control Valve

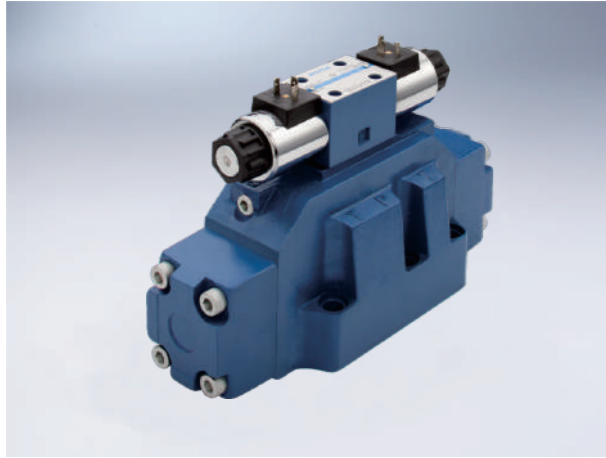

Electro-hydraulic directional control valve is a control valve which can use the pressure of the hydraulic circuit to pull the spool and change the hydraulic oil direction.

Electro-hydraulic directional control valve is the combination of the electrical operated directional control valve and the hydraulic operated directional control valve. It uses the electrical operated directional control valve to control the hydraulic operated directional control valve, and change the hydraulic oil direction.

Electro-hydraulic directional control valve and hydraulic operated directional control valve are used mostly in hydraulic systems when electrical operated directional control valve can not afford the flow. It may control the movement of the power elements, or control the direction of the flowing oil.

Technical specification

Specification		03		04		06		10	
Model		FWH-03	HFWH-03	FWH-04	HFWH-04	FWH-06	HFWH-06	FWH-16	HFWH-16
Max. Working pressure (MPa)	P, A, B Port	28	35	28	35	28	35	28	35
	T port (internal leakage of control oil)	10		10		10		10	
	Y port (external leakage of control oil)	10		10		10		10	
Minimum control pressure (MPa)		1.0 Spring-Return 4/3 valve 4/2 valve		1.2 Spring-Return 4/3 valve 4/2 valve		1.3 Spring-Return 4/3 valve 4/2 valve		0.8 Spring-Return 4/3 valve 4/2 valve	
Maximum control pressure (MPa)		to 25							
Max. Flow (L/min)		160		300		650		1100	
Working fluid		Mineral oil; phosphate-ester							
Fluid temp. (°C)		-20~70							
Viscosity (mm ² /s)		2.8~380							
Cleanliness	The maximum allowable cleanliness of the oil should be according to 9th degree of Standard NAS1638. It is suggested that the minimum filter rating should be β 10 ≥ 75.								

Electro-hydraulic Directional Control Valve

Model description

* FWH/FH - * * - * - * * * * / * * * * * * * 5X *

Working pressure Omit 28MPa H 35MPa	Remarks
FWH Electro-hydraulic directional control valve FH Hydraulic operated directional control valve	Serial number
Specification 03 DN10 04 DN16 06 DN25 10 DN32	Seal material Omit NBR Seals V FPM Seals
Main valve return type Omit Spring return H Hydraulic centration	²¹ Omit No reducing valve D3 With reducing valve
Function code Details as following symbol table	¹ Omit Without pre-load valve P4.5 With pre-load valve
Working voltage D12 DC12V D24 DC24V A110 AC110V A220 AC220V B110 AC110V Rectified B220 AC220V Rectified	Omit without stroke adjusting device A Head A of main valve with stroke adjustment B Head B of main valve with stroke adjustment W Both heads with stroke adjustment
Z5L Square connector with light Z6 Wire box type	Omit without shifting time adjustment S With shifting time adjustment: Inlet flow control S1 shifting time adjustment: Outlet flow control
Omit without hand emergency N9 with concealed hand emergency	Omit without damping 08 Φ0.8 Damping 10 Φ1.0 Damping 12 Φ1.2 Damping
	Omit Intl cntrl intl disch XY Extl cntrl extl disch X Extl cntrl intl disch Y Intl cntrl extl disch

Explanation

- For neutral unloaded directional control valve it must be ordered separately. There is no model (FWH-03) Electro-hydraulic directional control valve NS10.
- Only applied when the controlling pressure is higher than 25MPa

Electro-hydraulic Directional Control Valve

Code symbol

Spring return

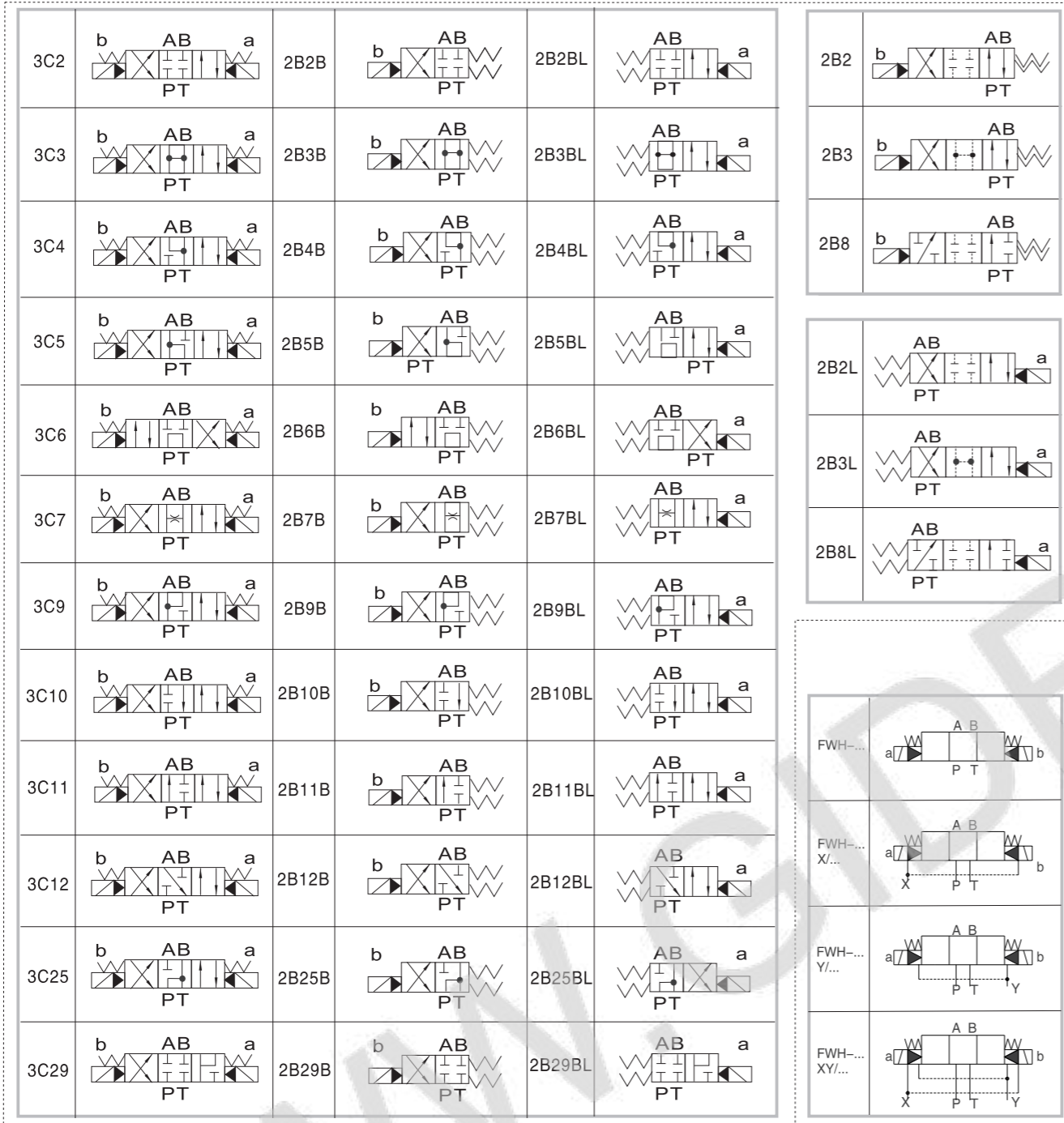

Electro-hydraulic Directional Control Valve

Name of solenoid

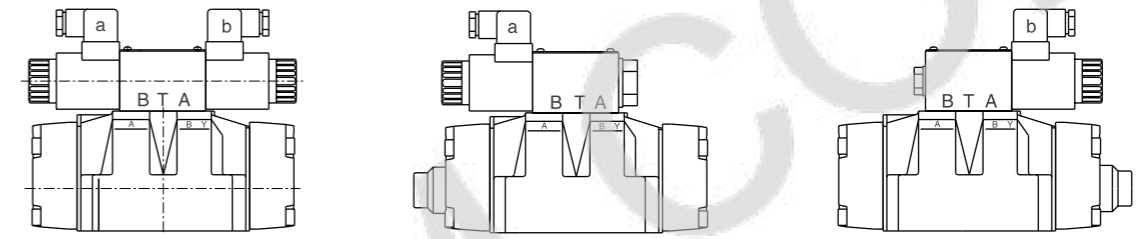

1. a When movement a, P→A B→T
2. b When movement b, P→B A→T
3. 3C6 Oil flow in the opposite direction with the above-mentioned movement.
Four 3C29, when solenoid "a" works, P→A,B

03 Specification Performance curve (Measured at $v=41\text{mm}^2/\text{s}$ and $t=50^\circ\text{C}$)

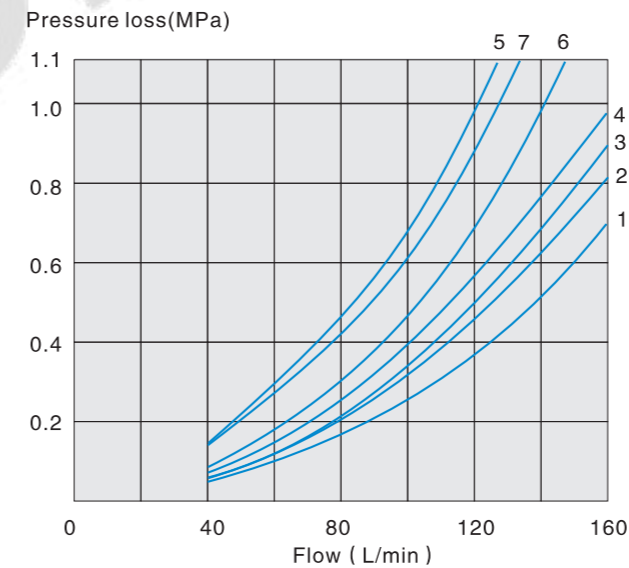

Function	Switching position			
	P→A	P→B	A→T	B→T
Symbol				
3C2	1	2	4	5
3C5	1	4	1	1
3C6	4	2	2	6
3C3	4	4	1	4
3C4	1	2	1	3
3C12	2	3	1	4
3C9	4	4	3	4
3C25	4	1	3	4
3C29	2	3	3	5
3C10	3	3	3	4
3C7	2	2	3	5

Function	Neutral		
	A→T	B→T	P→T
3C5	3	-	6
3C6	-	-	7
3C3	1	3	5
3C25	-	7	5

Function	Neutral		
	A→T	B→T	P→T
3C12	3	-	-
3C10	-	4	-

Electro-hydraulic Directional Control Valve

04 Specification Performance curve (Measured at $v=41\text{mm}^2/\text{s}$ and $t=50^\circ\text{C}$)

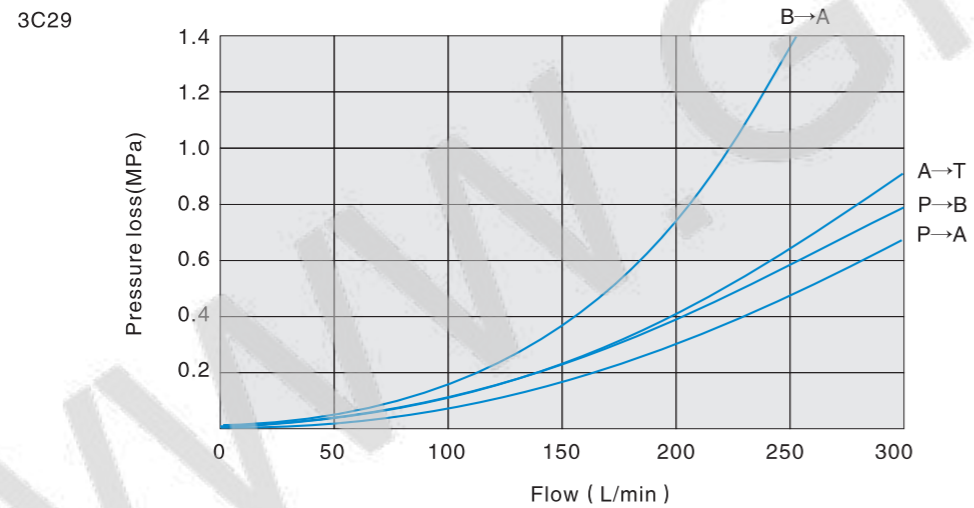
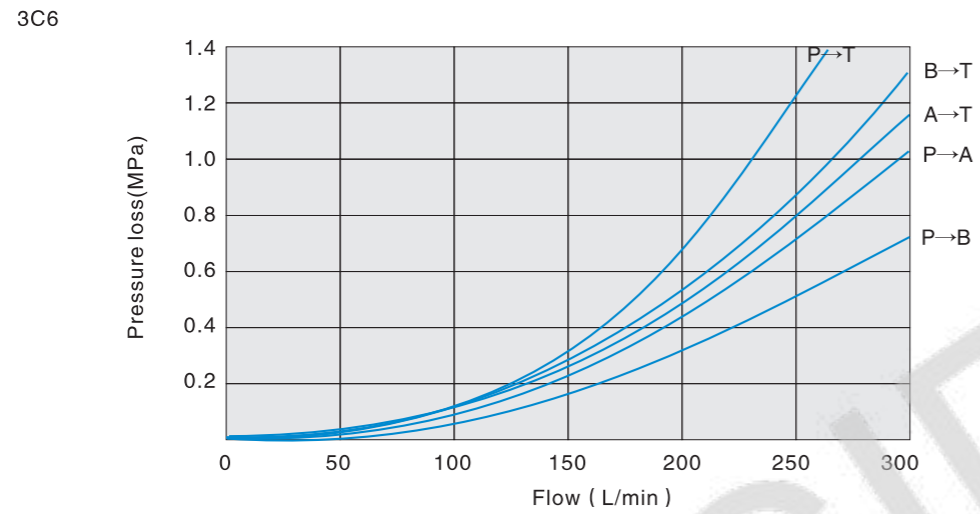
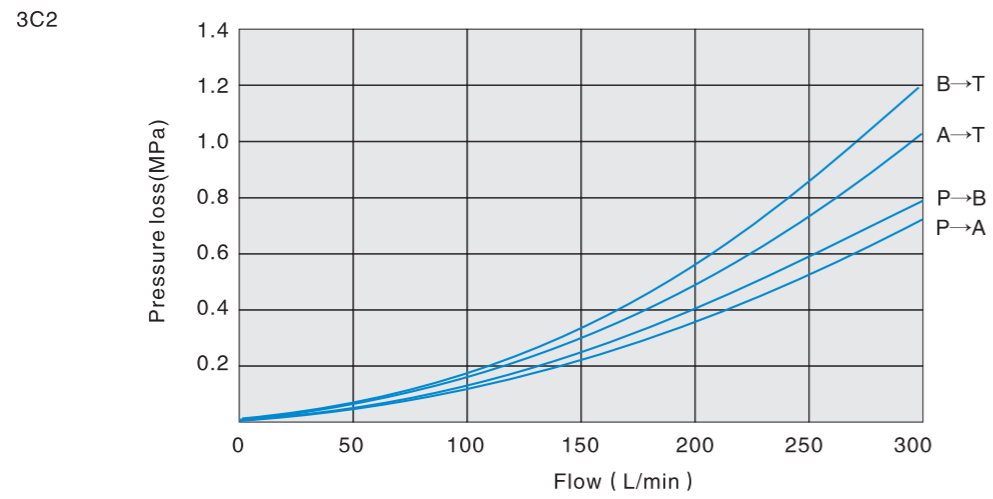

Electro-hydraulic Directional Control Valve

06 Specification Performance curve (Measured at $v=41\text{mm}^2/\text{s}$ and $t=50^\circ\text{C}$)

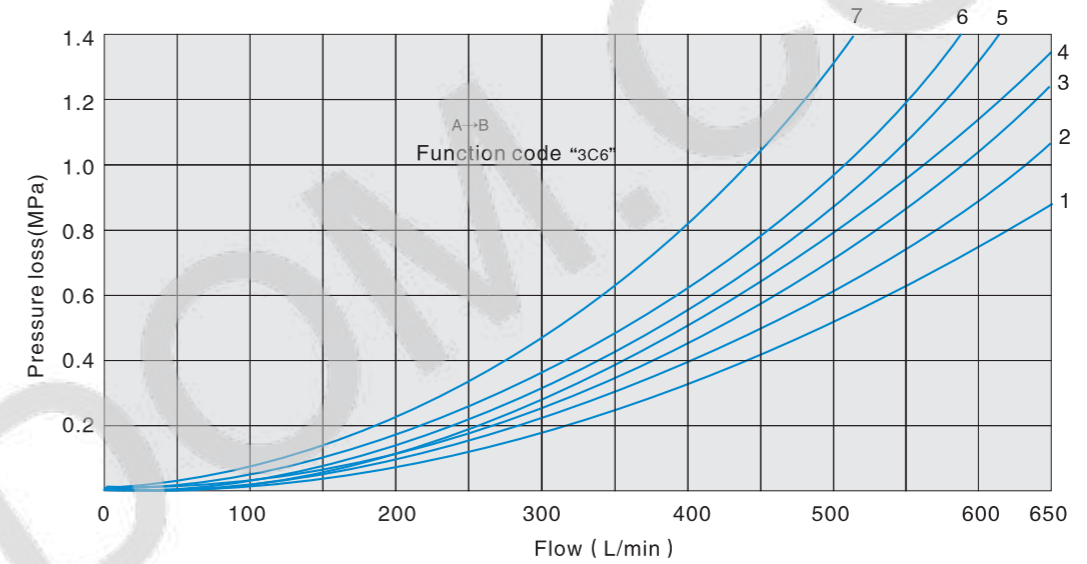

Function	Switching position			
	P→A	P→B	A→T	B→T
3C2	1	1	1	3
3C5	1	4	3	3
3C6	3	1	2	4
3C3	4	4	3	4
3C4	2	2	3	5
3C12	2	2	3	3
3C9	4	4	1	4
3C25	4	1	1	5
3C29	2	1	1	-
3C10	2	1	1	6
3C7	4	4	3	6

7.Function code "3C6" type, neutral position P→T
8.Function code "3C29" type, control position A→B

Electro-hydraulic Directional Control Valve

10 Specification Performance curve (Measured at $v=41\text{mm}^2/\text{s}$ and $t=50^\circ\text{C}$)

3C2, 3C4, 3C29

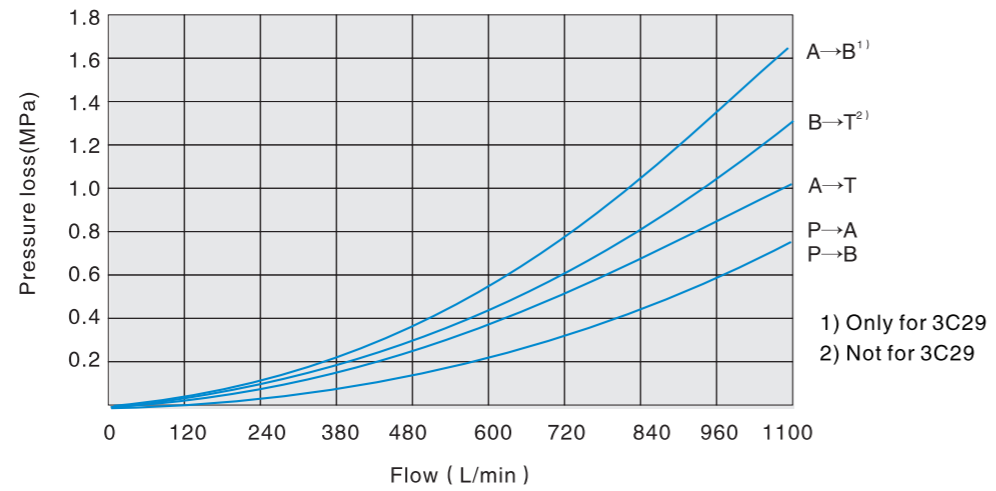

3C6

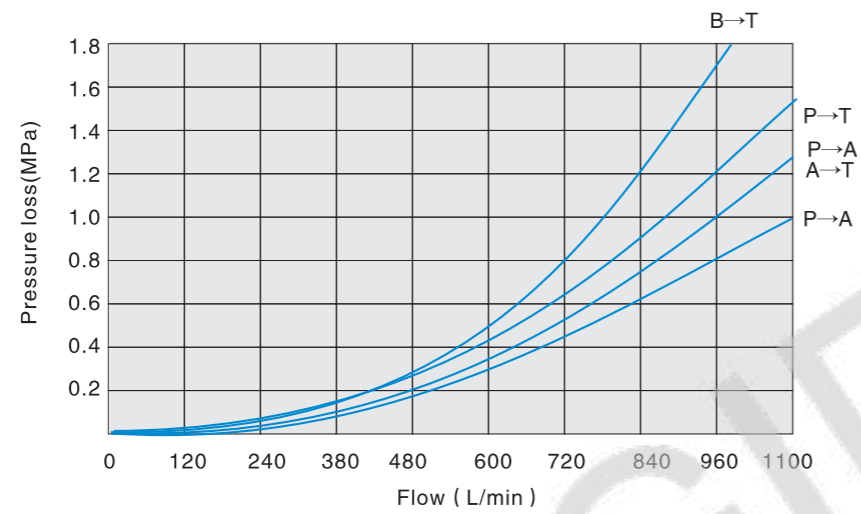

Other spool types

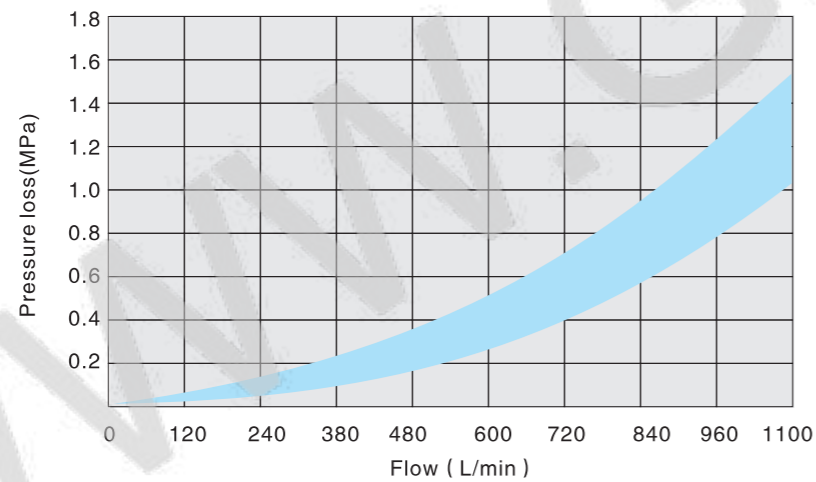

Electro-hydraulic Directional Control Valve

External dimensions (03 Direct current plug type)

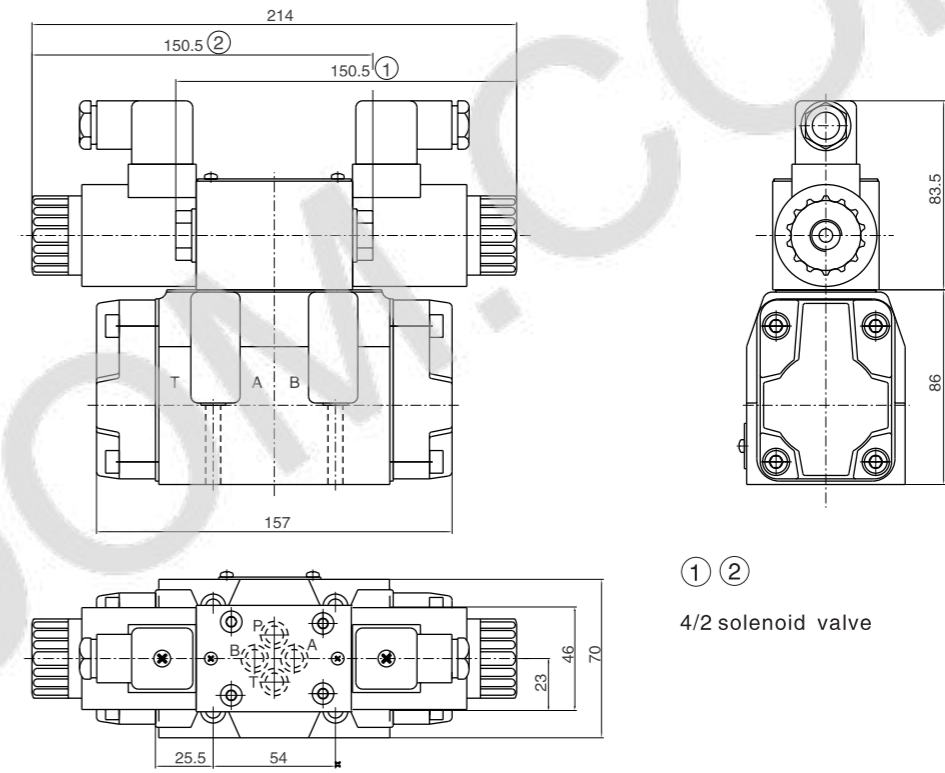

External dimensions (03 Direct current wire box type)

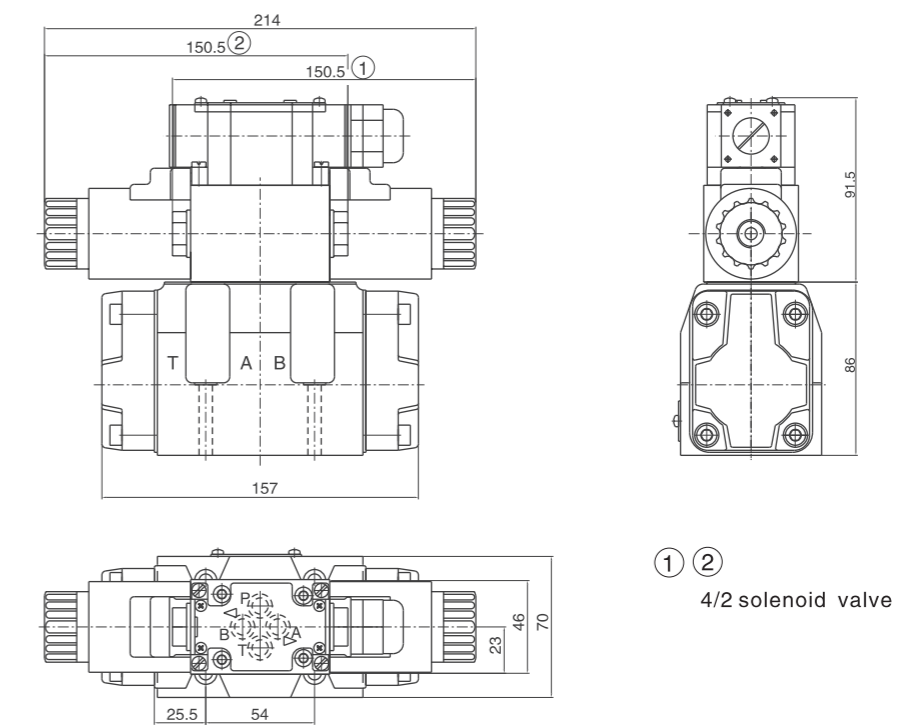

Electro-hydraulic Directional Control Valve

External dimensions (03 Alternating current plug type)

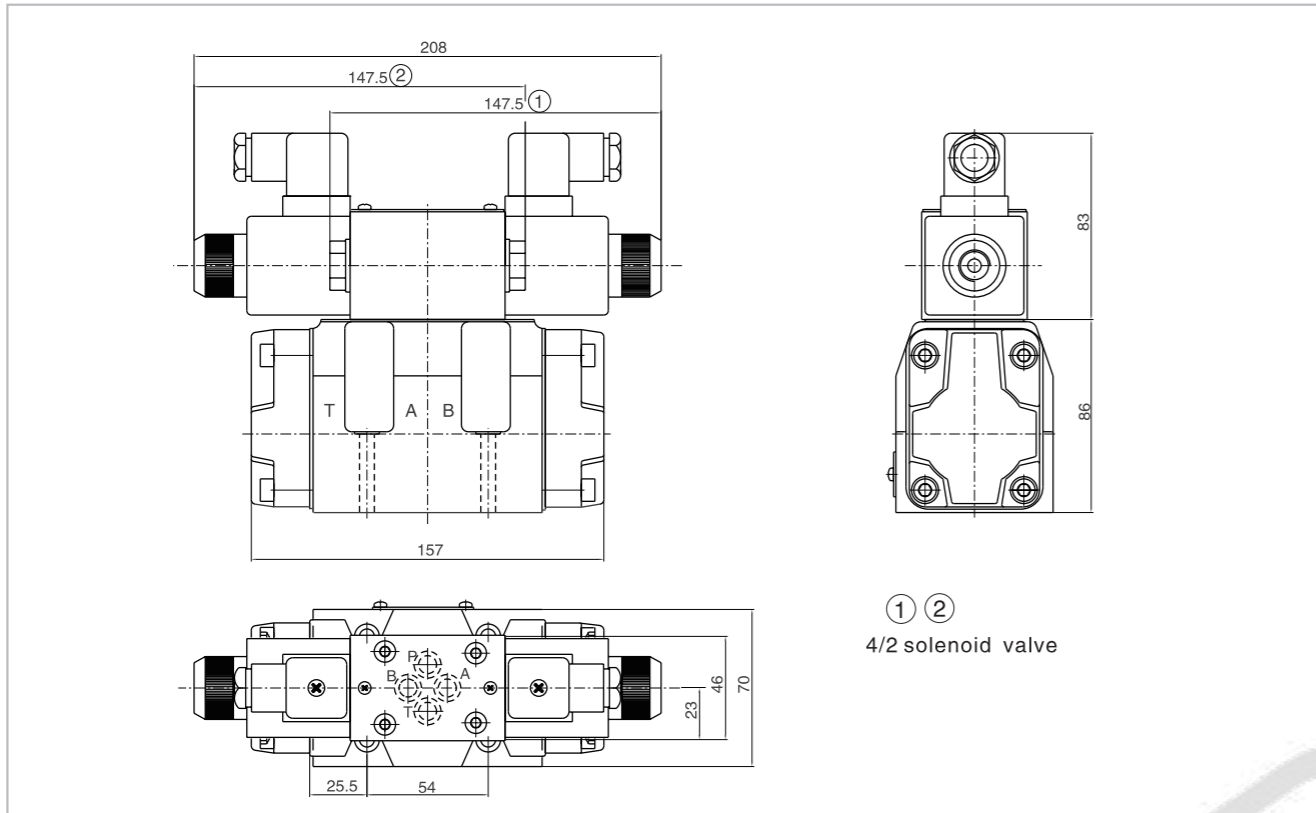

Electro-hydraulic Directional Control Valve

03 Size of subplate oil port

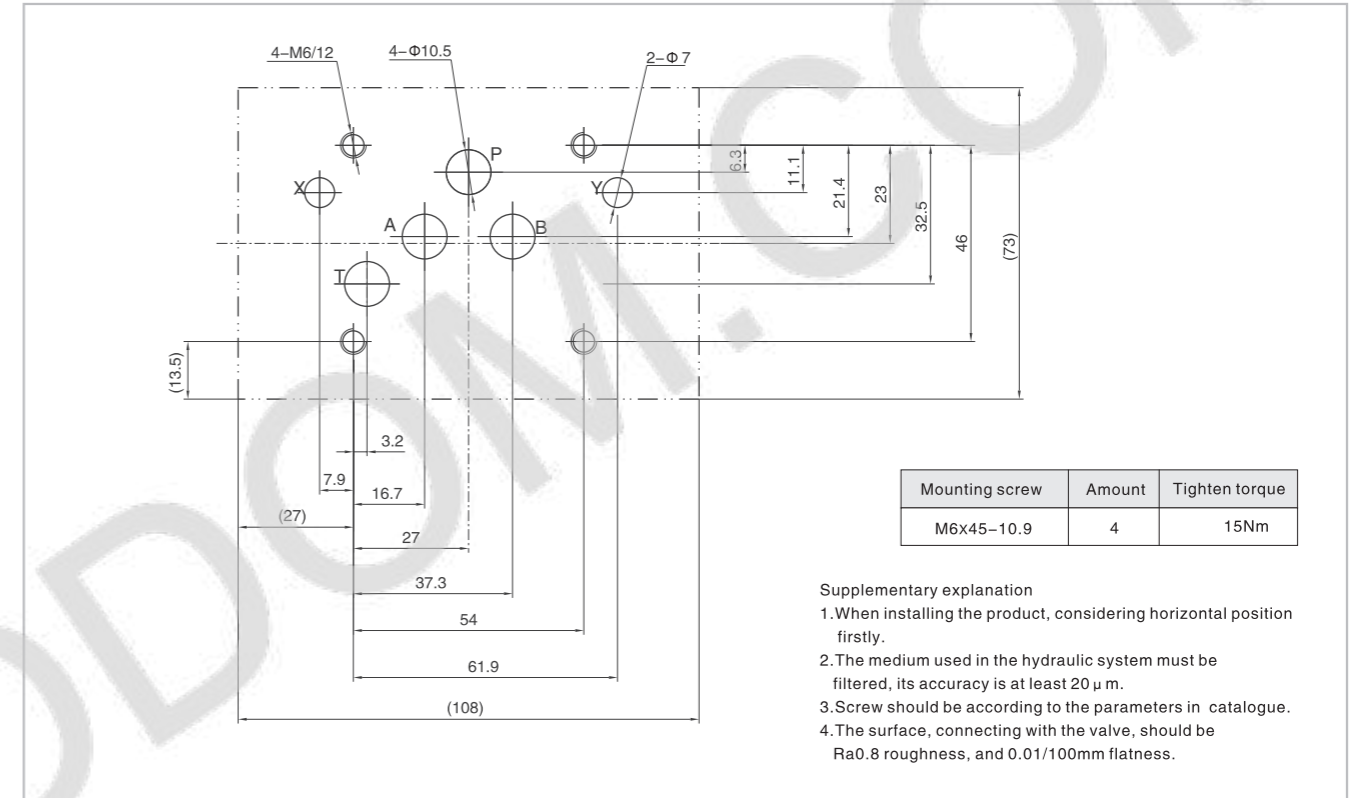

External dimensions (03 Alternating current wire box type)

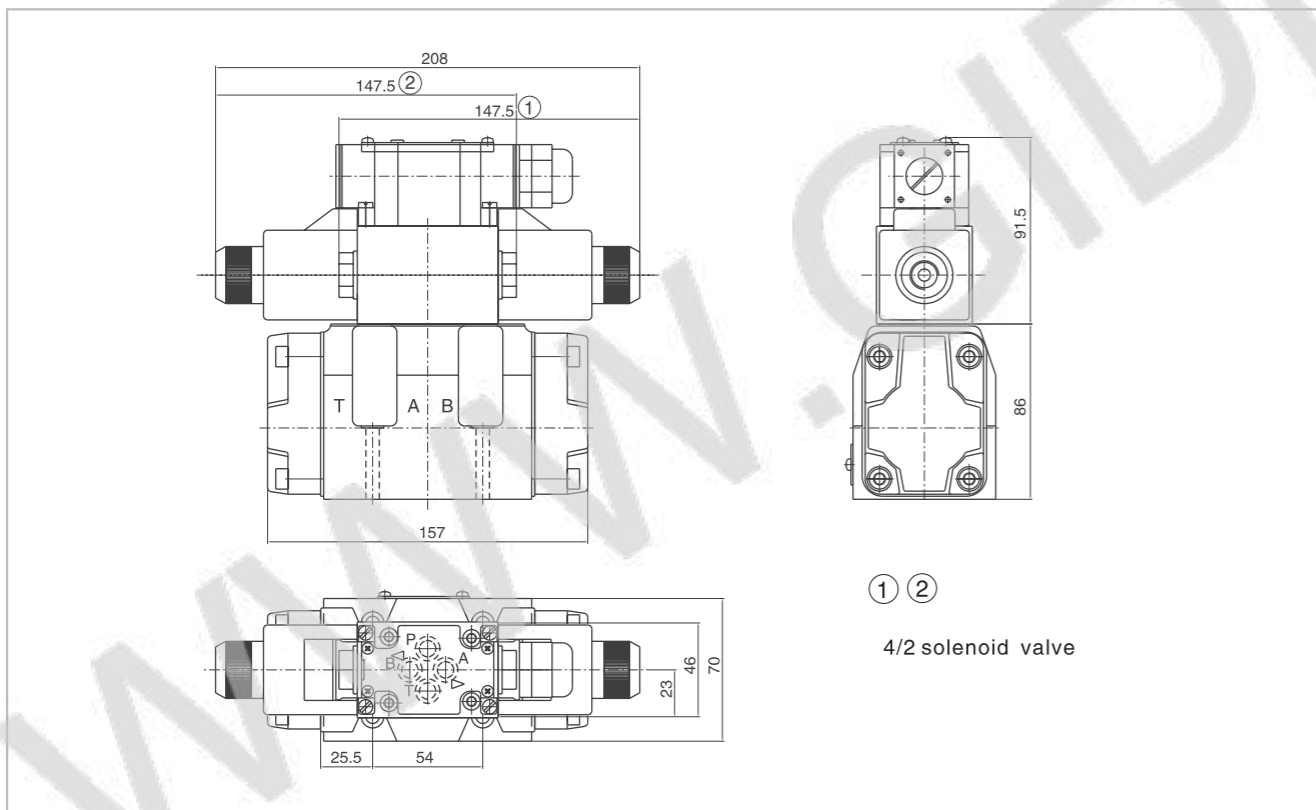

External dimensions (04 Direct current plug type)

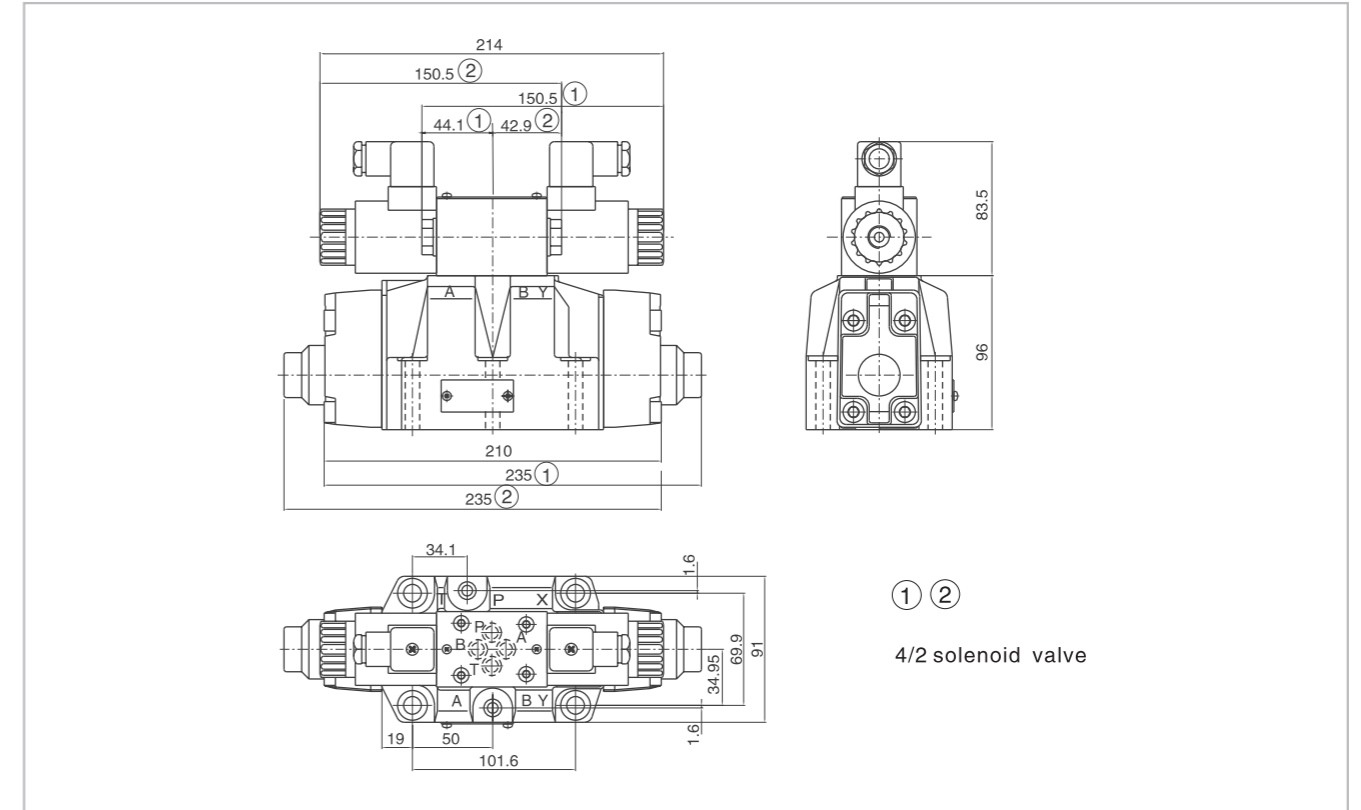

Electro-hydraulic Directional Control Valve

External dimensions (04 Direct current wire box type)

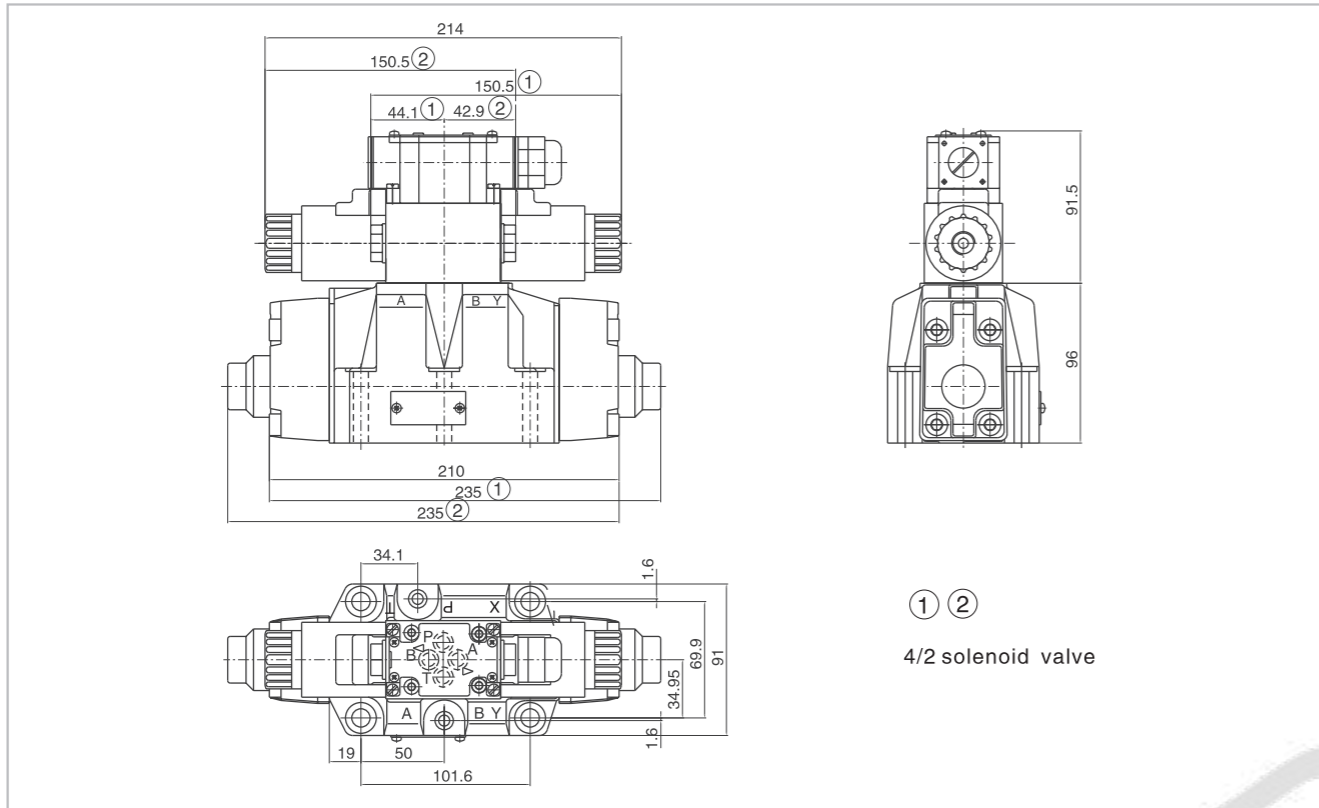

Electro-hydraulic Directional Control Valve

External dimensions (04 Alternating current wire box type)

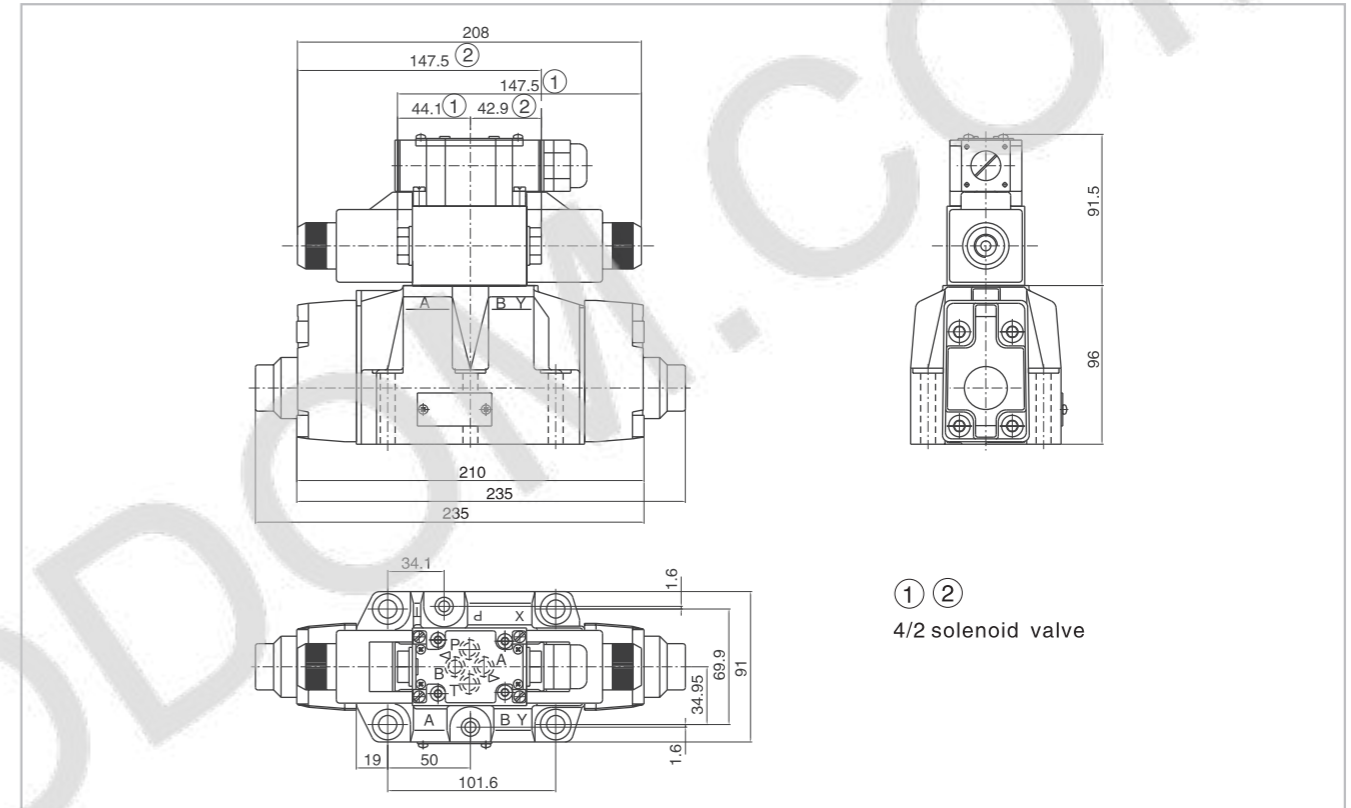

External dimensions (04 Alternating current plug type)

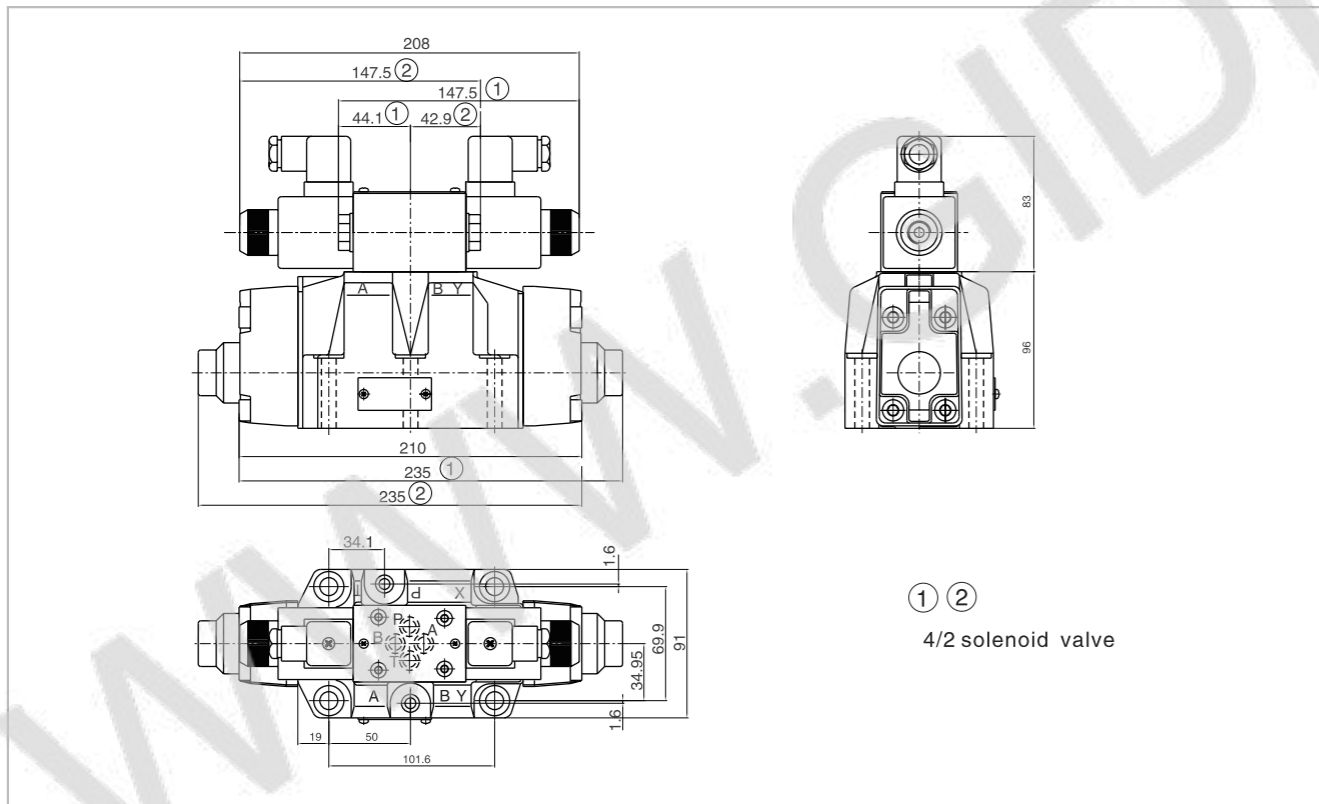

04 Size of subplate oil port

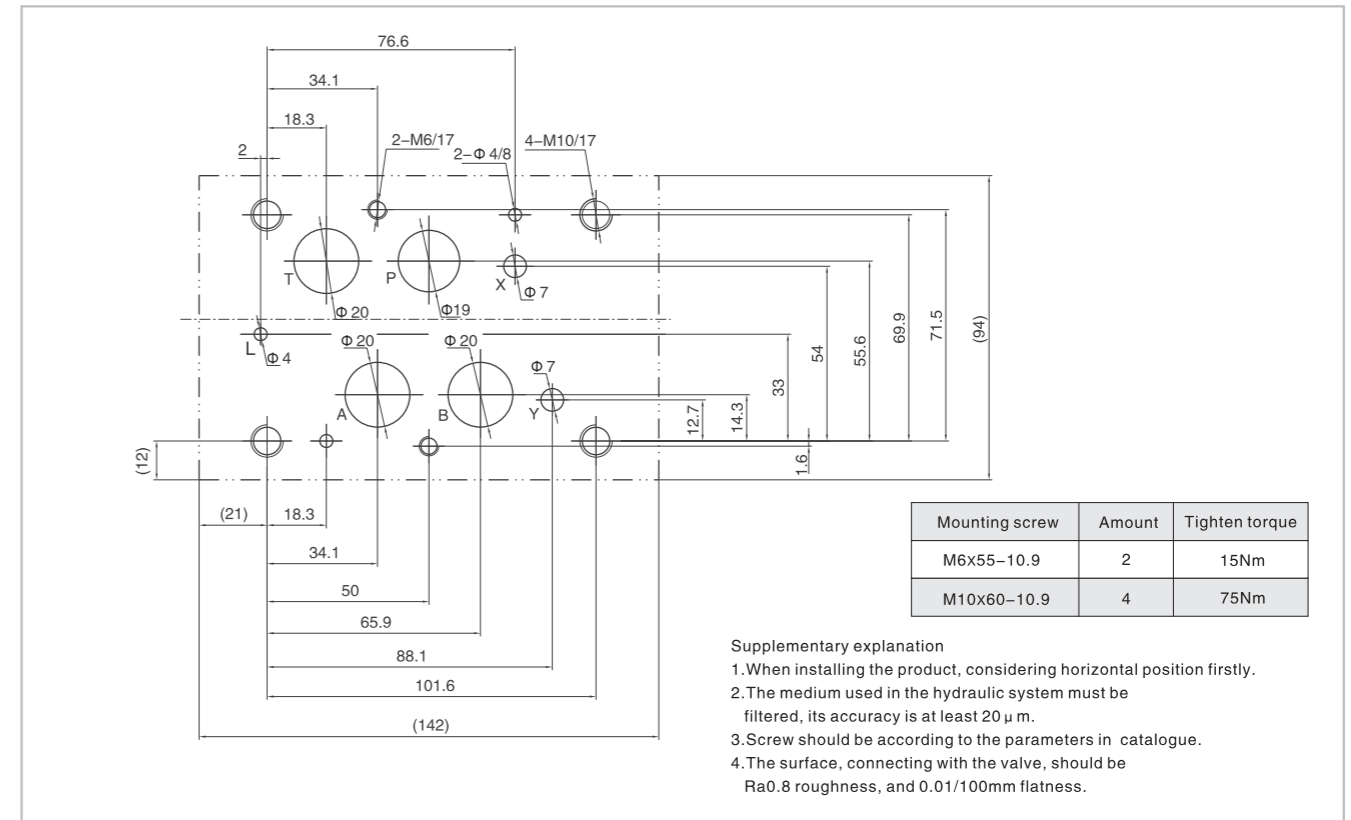

Electro-hydraulic Directional Control Valve

External dimensions (06 Direct current plug type)

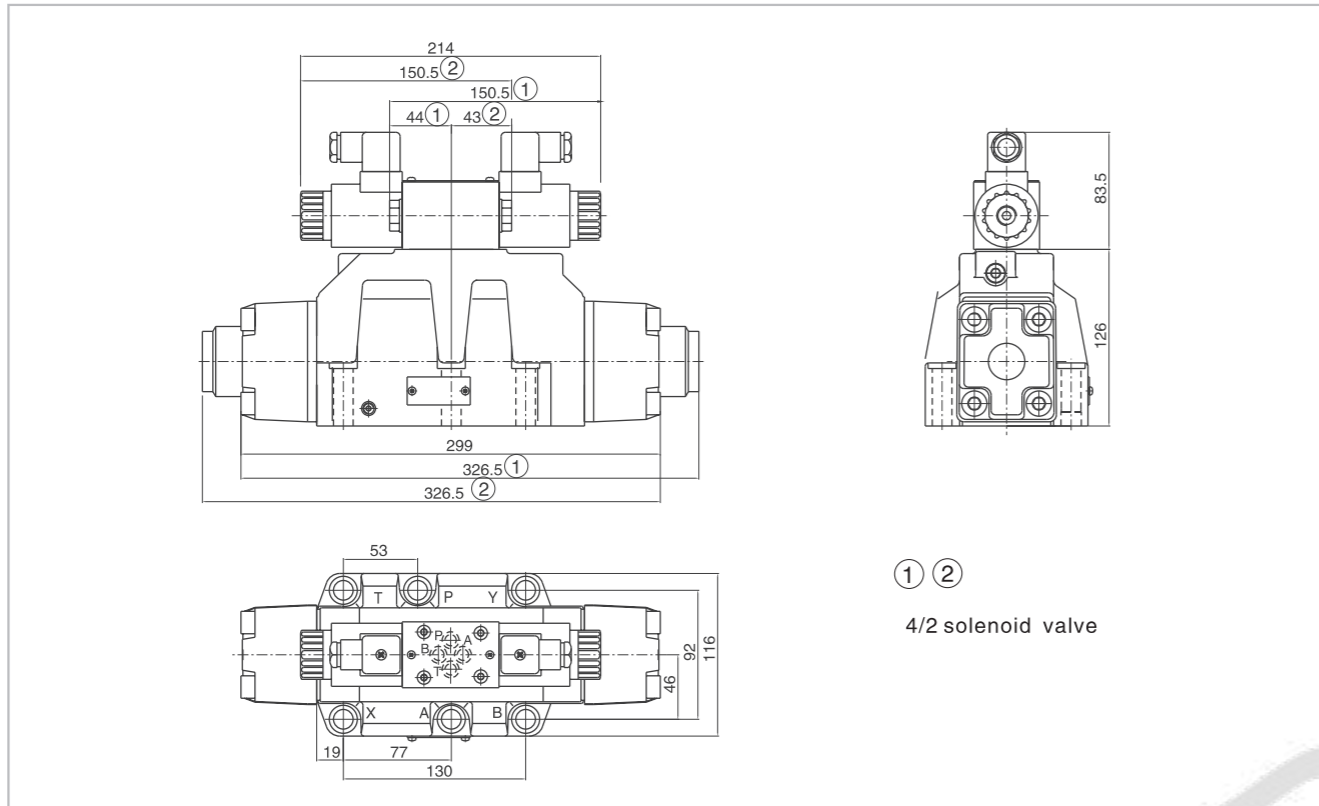

D.6.13

Electro-hydraulic Directional Control Valve

External dimensions (06 Alternating current plug type)

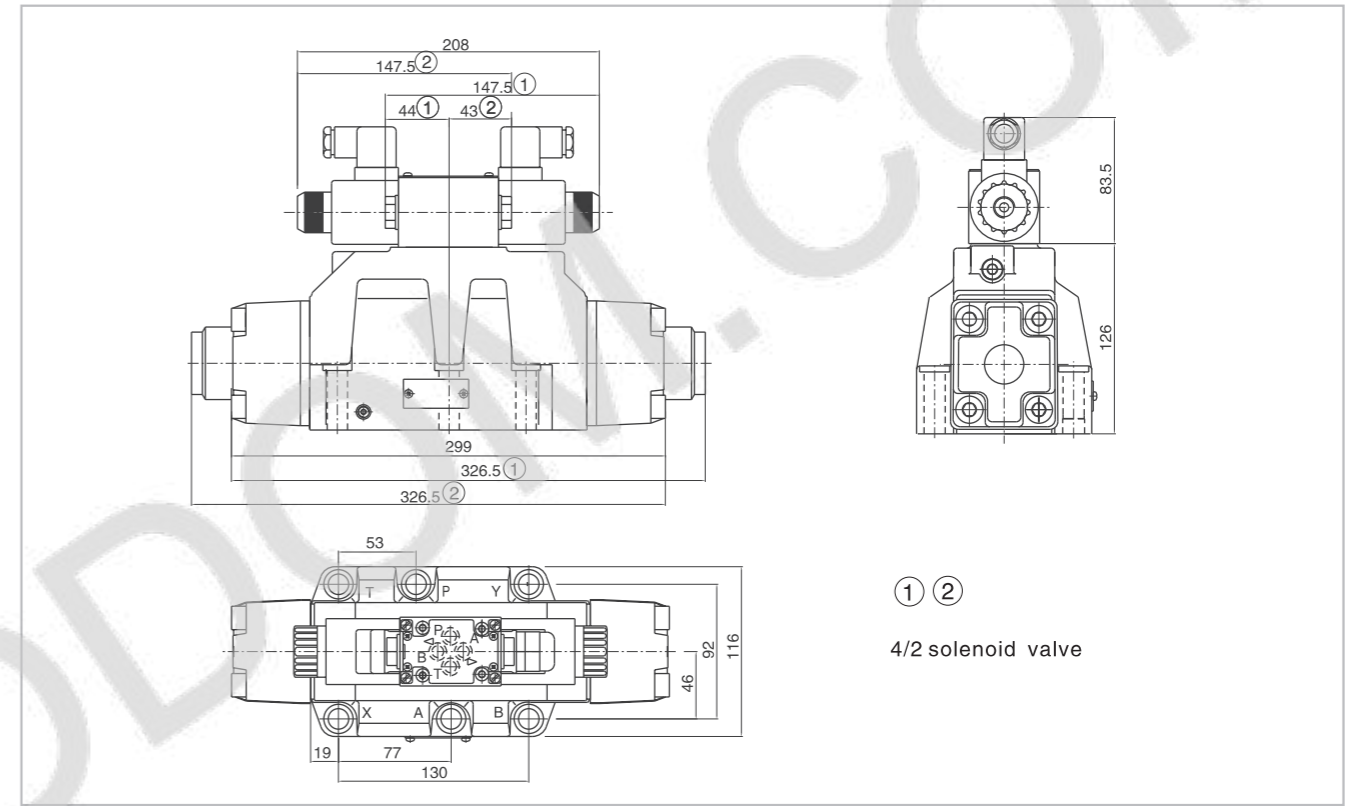

D.6.14

External dimensions (06 Direct current wire box type)

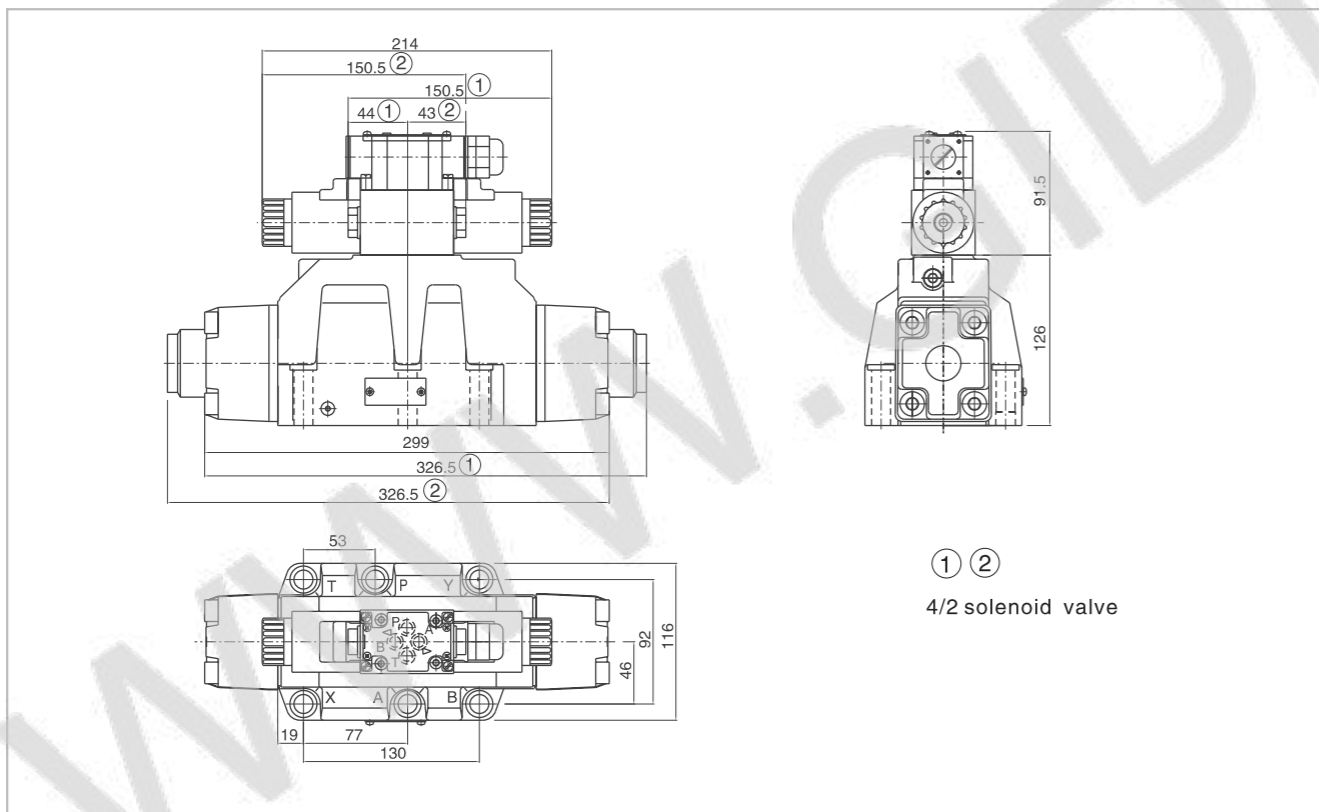

External dimensions (06 Alternating current wire box type)

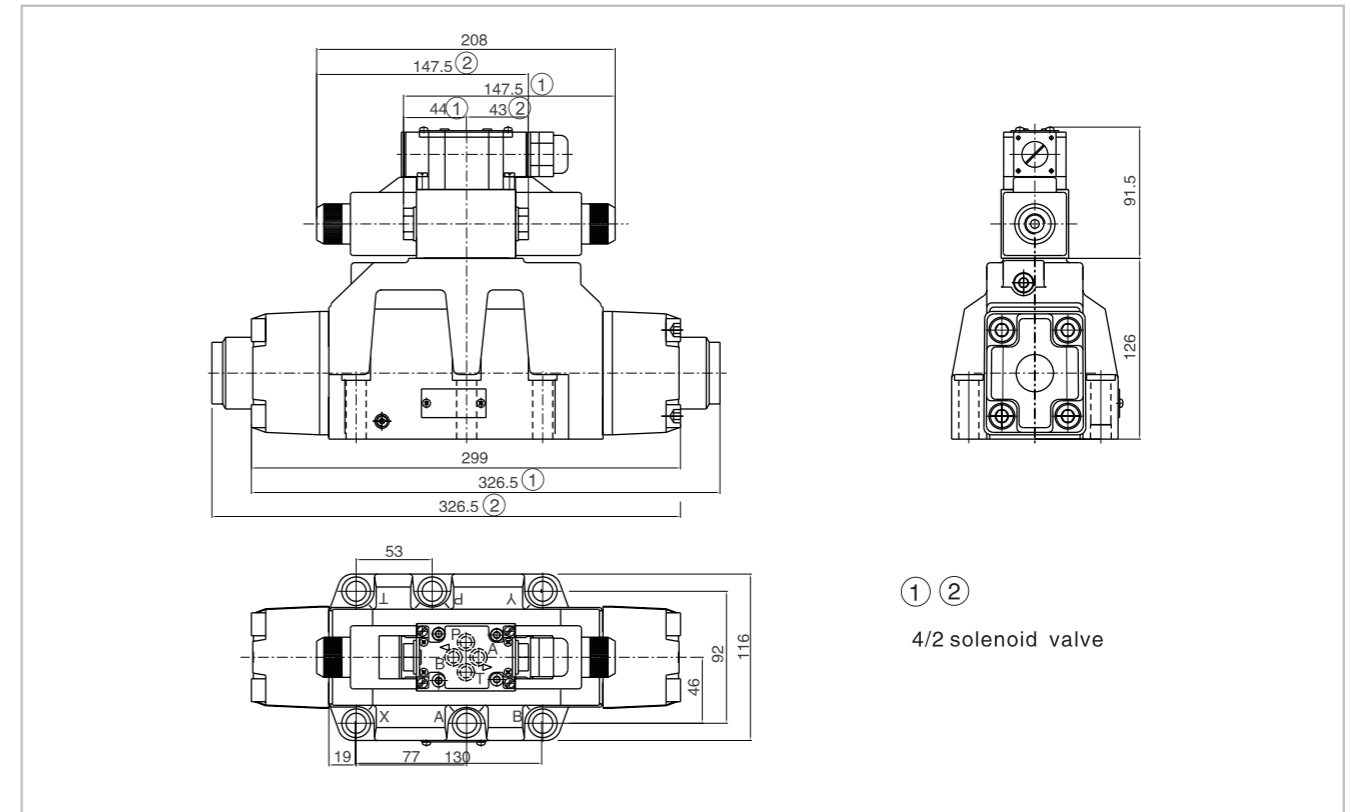

Electro-hydraulic Directional Control Valve

06 Size of subplate oil port

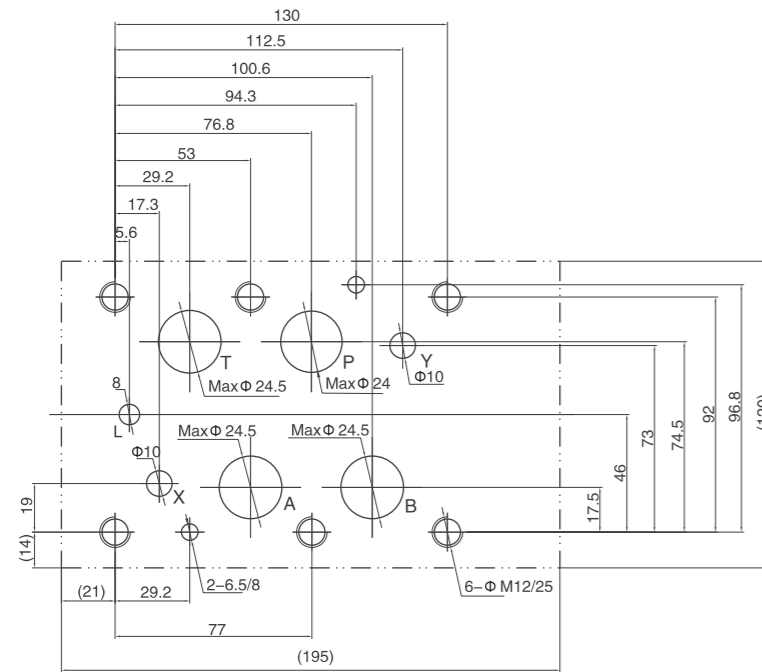

Mounting screw	Amount	Tighten torque
M12x60-10.9	6	130Nm

- Supplementary explanation
1. When installing the product, considering horizontal position firstly.
 2. The medium used in the hydraulic system must be filtered, its accuracy is at least 20 μm.
 3. Screw should be according to the parameters in catalogue.
 4. The surface, connecting with the valve, should be Ra0.8 roughness, and 0.01/100mm flatness.

Electro-hydraulic Directional Control Valve

External dimensions (10 Direct current wire box type)

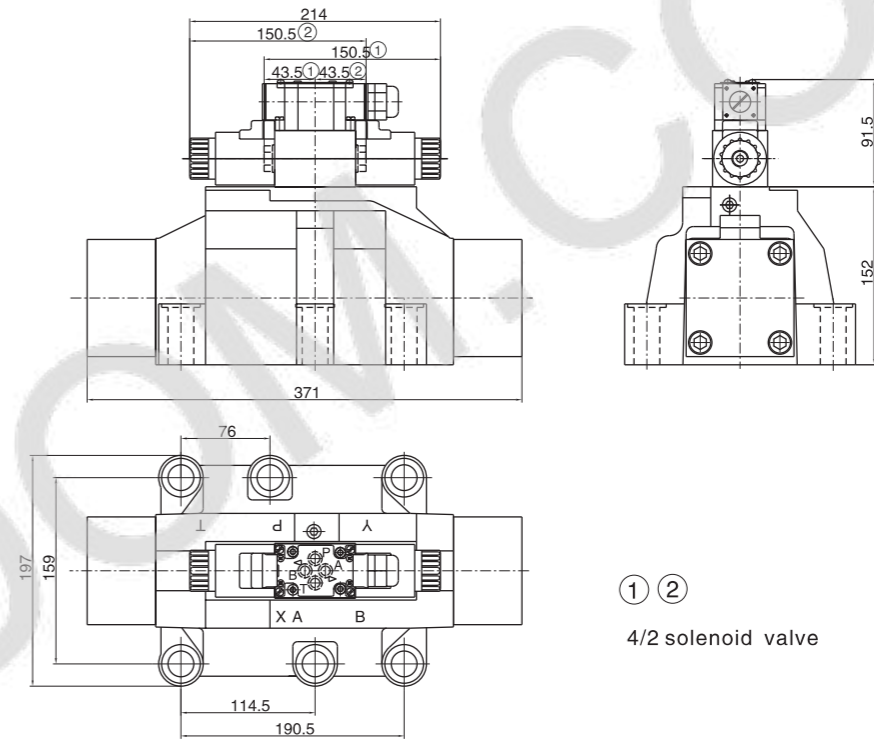

External dimensions (10 Direct current plug type)

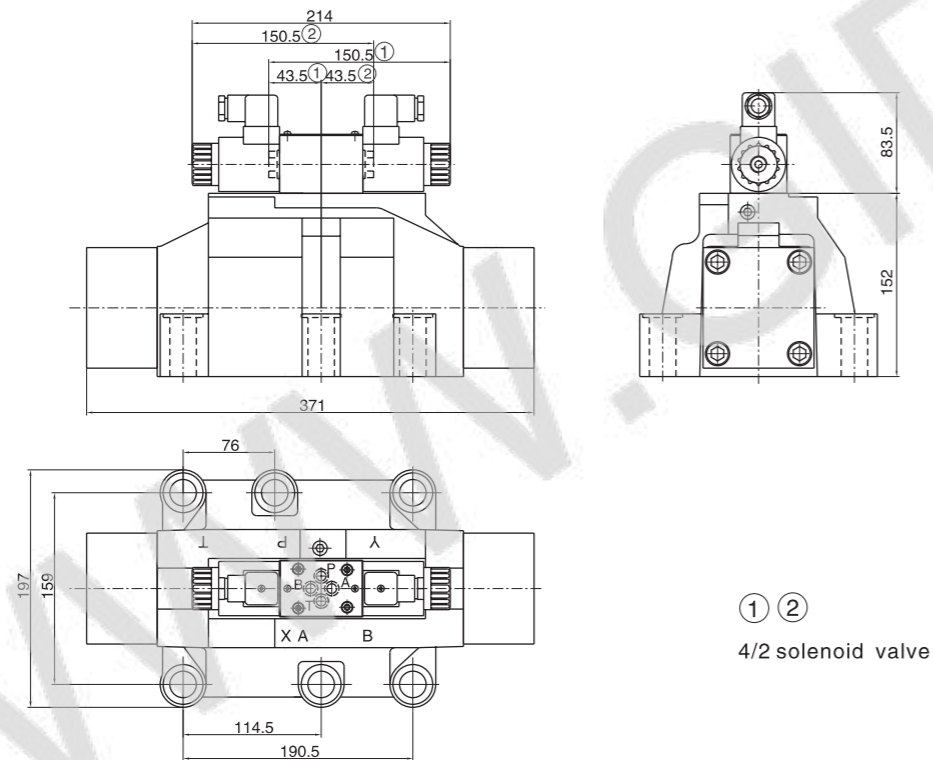

External dimensions (10 Alternating current plug type)

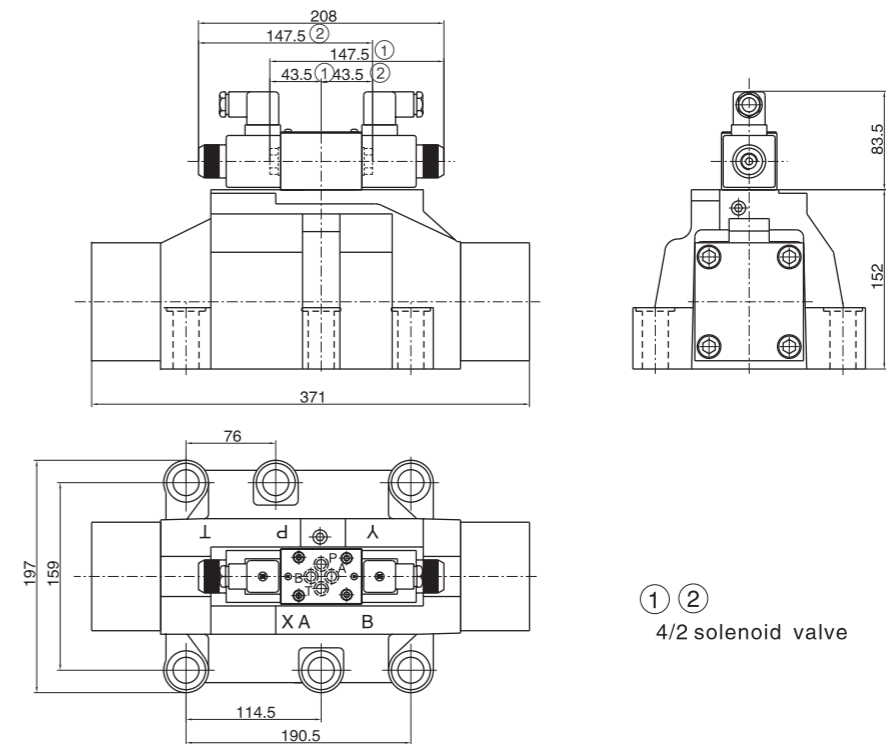

Electro-hydraulic Directional Control Valve

External dimensions (10 Alternating current wire box type)

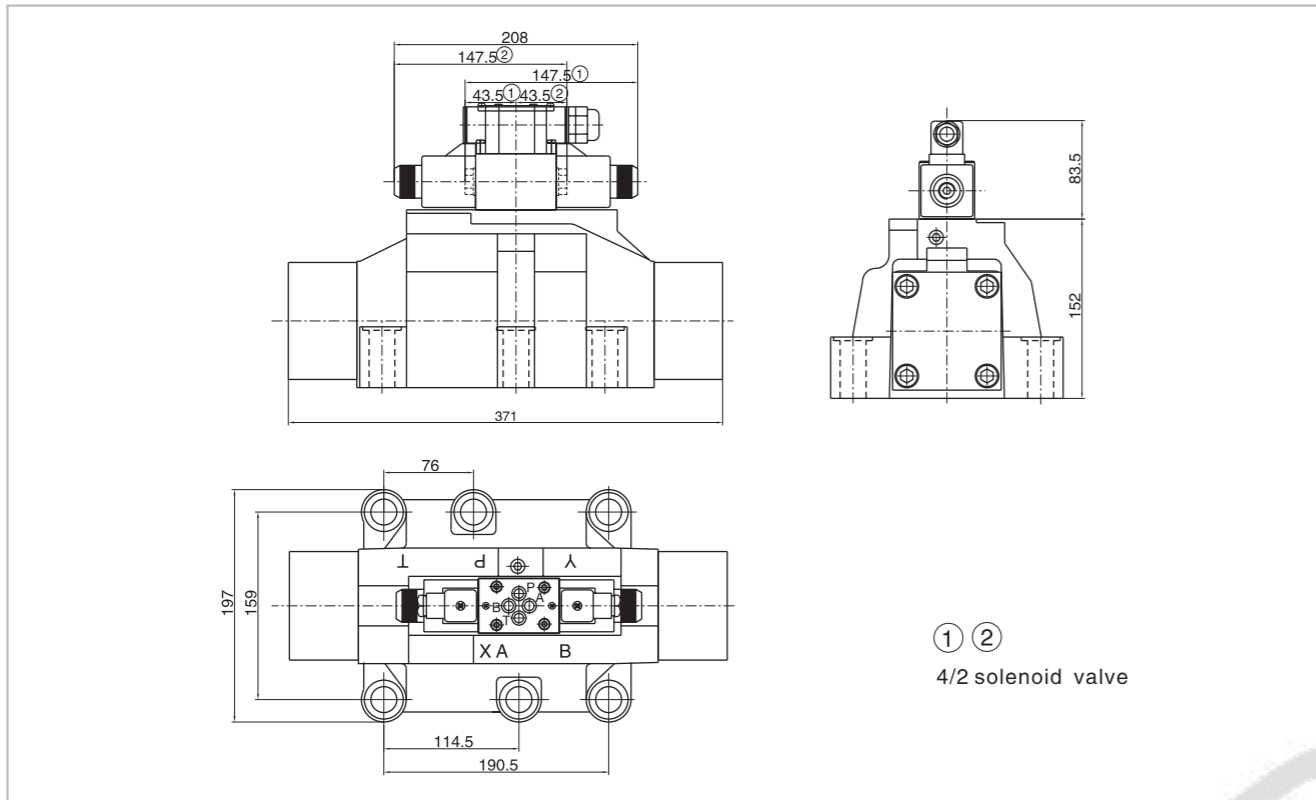

10 Size of subplate oil port

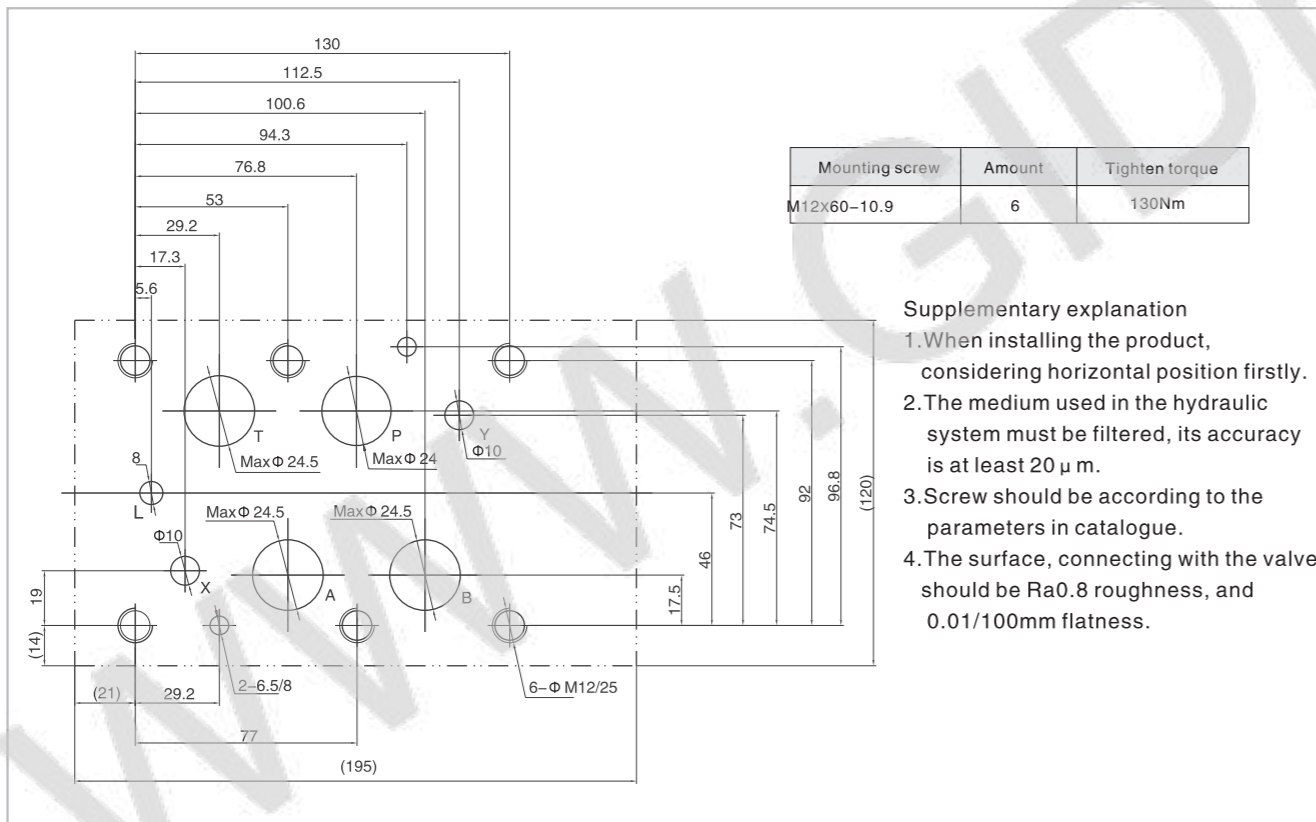

Manual operated Directional Control Valve

Technical specification



Specification	02	03	04	06
Working pressure (MPa)	Port P, A, B	31.5		
	Port T	10		
Max. Flow (L/min)	60	100	300	450
Working fluid	Mineral oil;phosphate-ester			
Fluid temp. (°C)	-20~70			
Viscosity (mm ² /s)	2.8~380			
Weight (kg)	About 1.4	About 3.3	About 8	About 17
	Cleanliness			
	The maximum allowable cleanliness of the oil should be according to 9th degree of Standard NAS1638. It is suggested that the minimum filter rating should be β 10≥75.			

Manual operated directional control valve is a directional control valve, by operating the handle, the spool moves in the axial direction to achieve oil loop switching.

Manual operated directional control valve and electrical operated directional control valve are played the same role in the hydraulic system. Easy operation, reliable work, and without the need for electricity.

Model description

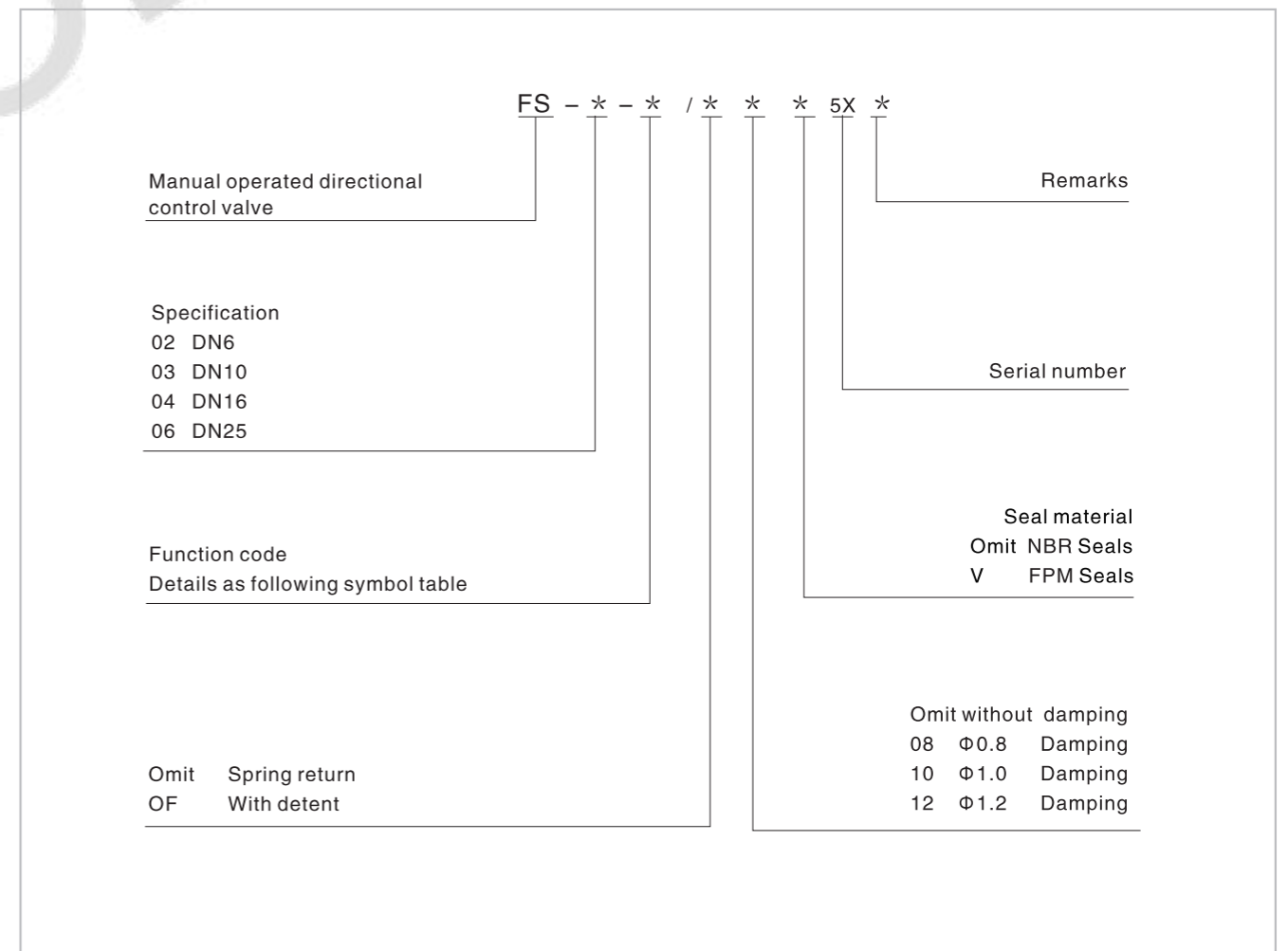

Manual Operated Directional Control Valve

Code symbol

Spring return			
With detent			

Manual Operated Directional Control Valve

The relationship between the location of the handle and the direction of the oil flow

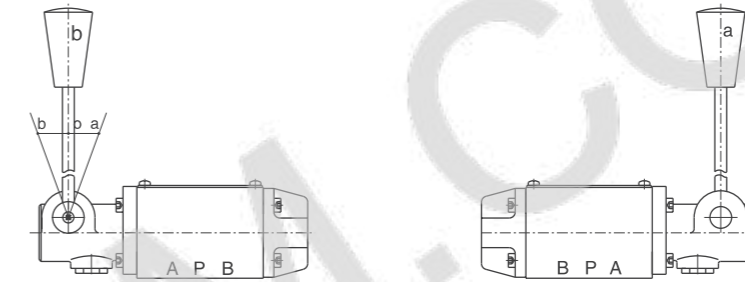

1. The name of the handle as shown in the picture
2. When the handle is on position b P→B A→T
3. When the handle is on position a P→A B→T
4. Oil flow in the opposite direction with the above-mentioned movement for 02/03:3C5,3C6.
Oil flow in the opposite direction with the above-mentioned movement for 04/06:3C6.
5. For specification 03 spool type 2B2L,2B3L, 2B8L, the handle is at the side of port B, details refer to the external dimension

02 Specification Performance curve (Measured at $\nu=41\text{mm}^2/\text{s}$ and $t=50^\circ\text{C}$)

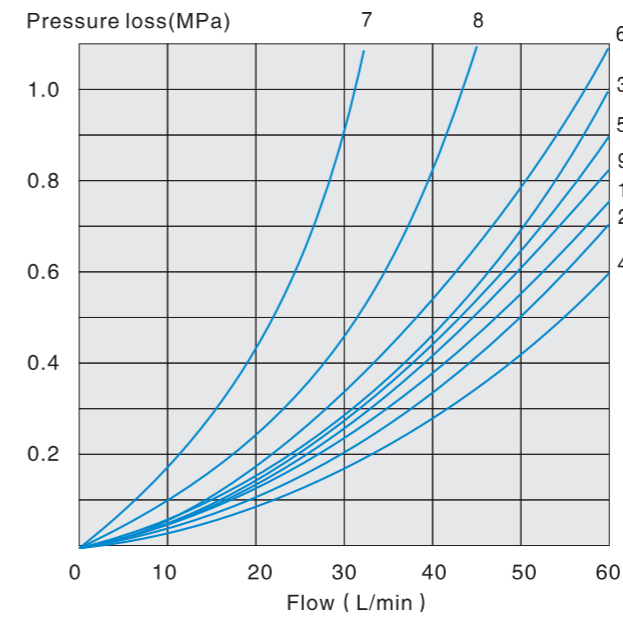

Function code	Direction			
	P→A	P→B	A→T	B→T
2B8 2B8L	3	3	-	-
2B3	1	1	3	1
2B2 2B2L	5	5	3	3
3C2	3	3	1	1
3C5	1	3	1	1
3C6	6	6	9	9
3C3	2	4	2	2
3C4	1	1	2	1
3C10,3C12	3	3	4	9
3C9	2	3	3	3
3C25	3	1	1	1
3C29	5	5	4	-
3C7	1	2	1	1

7. Spool type "3C29" located in the control position A→B
8. Spool symbol 3C6 in the neutral position P→T

Manual Operated Directional Control Valve

02 Specification Working limits (The working limits for directional valve have determined by using solenoids at their operating temperature, 10% under voltage and with no pre-loading of the tank.)

As the plug, the switch function of the valve is determined by the filter. In order to reach the largest flow as shown, we suggest to use full-flow filter 20 μm. Every force on the valve can also affect the flow. With regard to the four-way valve, the normal flow data as shown is get from the regular use of two directions of the flow (e.g.P to A, and simultaneous return flow from B to T). See tables. If only one flow direction is needed, for example: When a four port valve which is closed up port A or port B, used as a three-way valve, the Maximum flow may be very small in the serious condition.

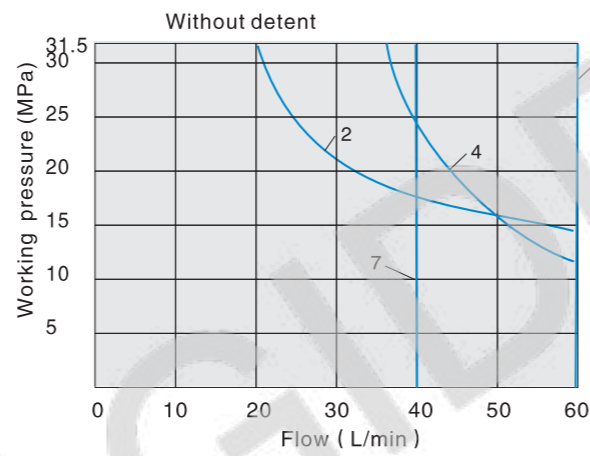
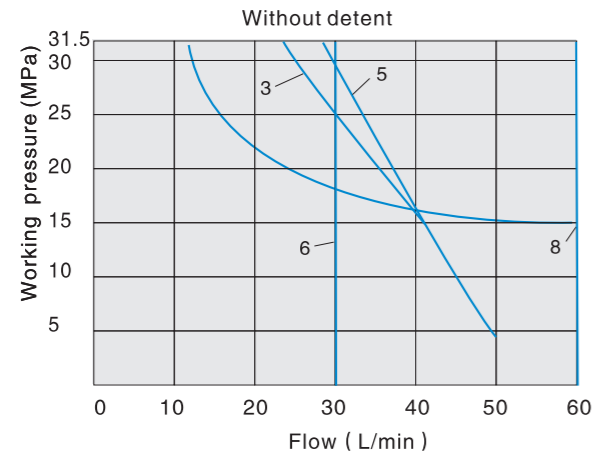
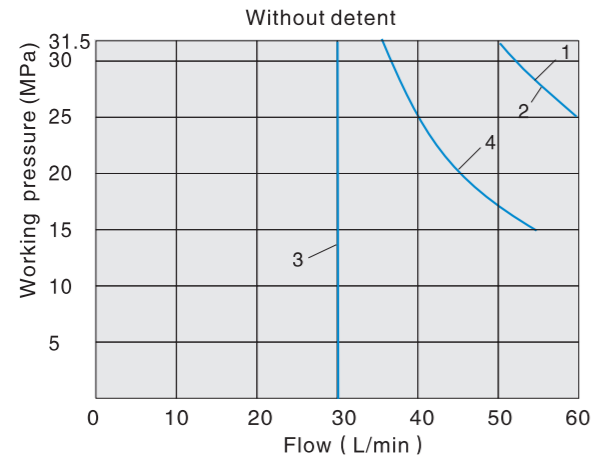

4. Spool symbol "3C6" in the median position P to T
7. Spool symbol "3C29" in the control position A to B

Performance curve	Function code	Performance curve	Function code
Without detent	1	With detent	1
	2		2
	3		3
	4		4
	3C2 3C3 2B3 2B2 3C9 3C10 3C6 3C4 3C12 3C29 2B2L		5
	2B8 2B8L		6
	3C7		7
	3C5 3C25		8
			3C9 3C3 2B3 2B2 2B2L 3C2 3C4 3C12 3C10 2B8 2B8L 3C6 3C5 3C7 3C25 3C29

Manual Operated Directional Control Valve

03 Specification Performance curve (Measured at $v=41\text{mm}^2/\text{s}$ and $t=50^\circ\text{C}$)

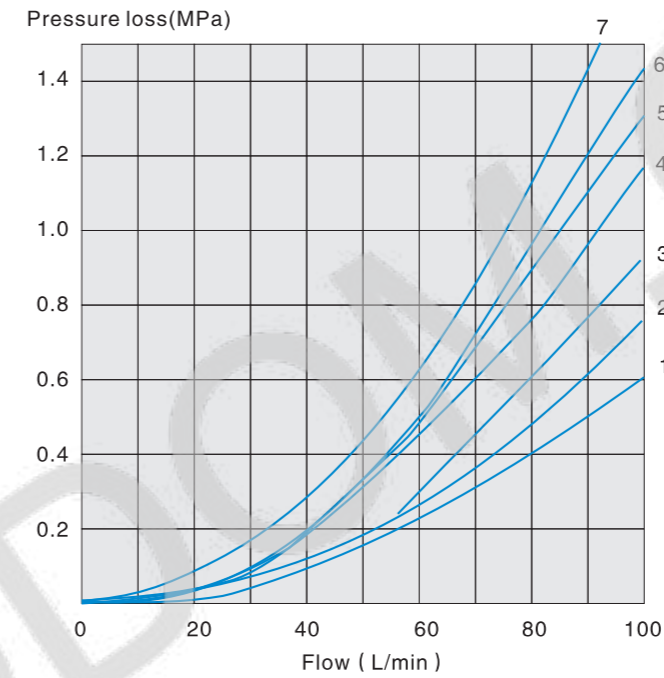

	P→A	P→B	A→T	B→T
2B8	2	2	-	-
2B8L	2	2	-	-
2B3	2	2	3	3
2B2	2	2	3	3
3C2	2	2	4	4
3C5	2	3	3	5
3C6	3	3	4	6
3C3	1	1	4	5
3C4	2	2	3	3
3C12	2	2	3	5
3C9	1	1	5	5
3C25	3	2	5	3
3C29	2	4	3	-
3C10	2	2	3	5
3C7	2	2	4	4
2B2L	2	2	5	3

4. Spool symbol "3C6" in the neutral position P → T
7. Spool type "3C29" located in the control position A → B

Working limits (The working limits for directional valves have determined by using solenoids at their operating temperature, 10% under voltage and with no pre-loading of the tank.)

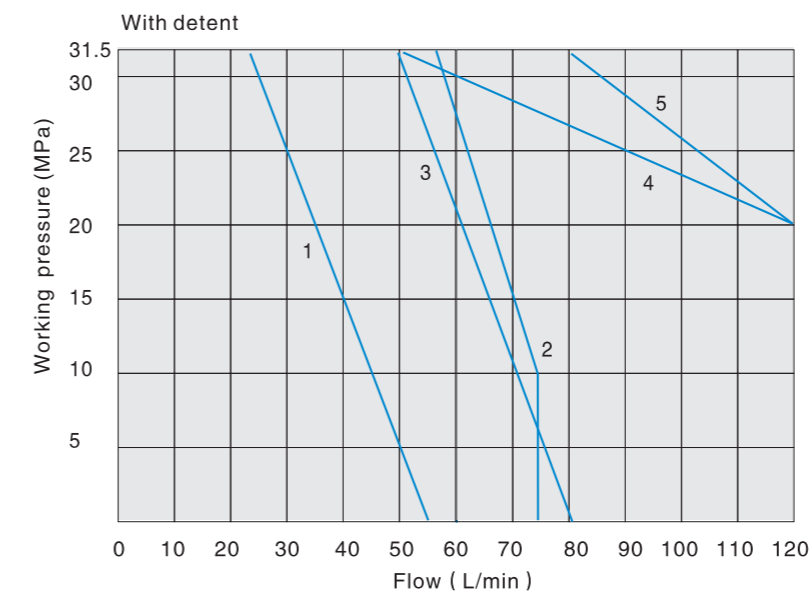

1	2B8 2B8L
2	3C3
3	3C5 3C6 3C25 3C29
4	3C4 3C12 3C10
5	2B2 2B3 3C2 3C9 3C7 2B2L

Manual Operated Directional Control Valve

04 Specification Performance curve (Measured at $v=41\text{mm}^2/\text{s}$ and $t=50^\circ\text{C}$)

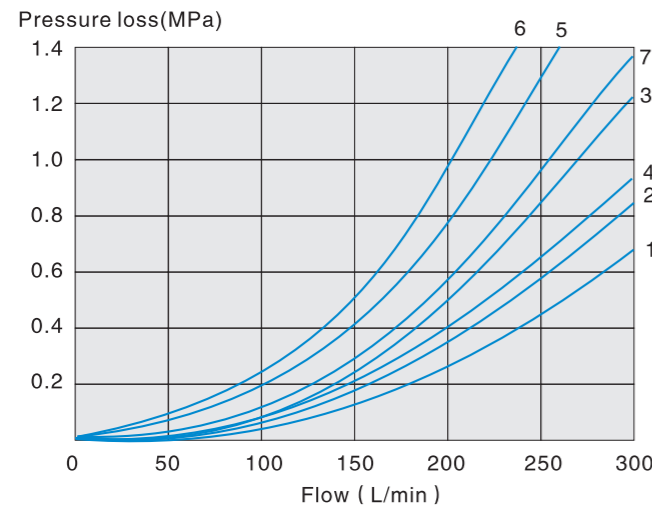

Function code	Direction			
	P→A	P→B	A→T	B→T
3C2 2B2 2B2L	1	1	1	3
3C5	2	2	3	3
3C6	5	1	3	7
3C3 2B3	2	2	3	3
3C7	2	2	3	3
3C4 3C12	1	1	3	3
3C29	2	2	4	-
3C10	2	2	4	-
3C	1	1	4	7

6. Spool symbol 3C6 in the neutral position P → T

Manual Operated Directional Control Valve

06 Specification Performance curve (Measured at $v=41\text{mm}^2/\text{s}$ and $t=50^\circ\text{C}$)

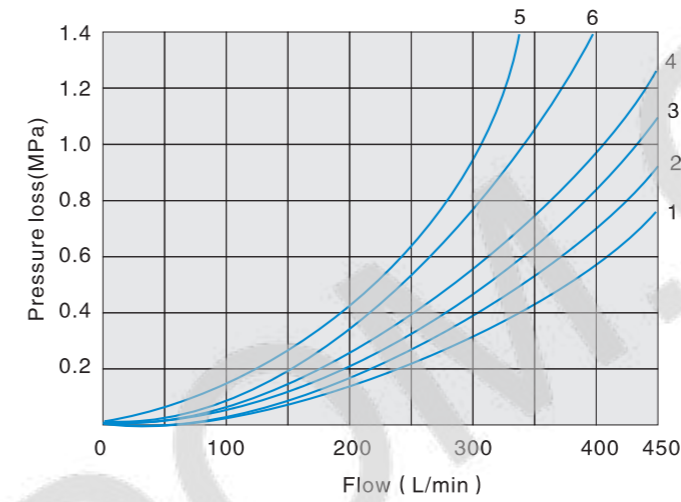

Function code	Direction			
	P→A	P→B	A→T	B→T
3C2	2	2	1	4
3C5	1	2	1	2
3C6	2	2	2	4
3C3	2	2	1	3
3C4	2	2	1	3
3C12	2	2	1	2
3C9	2	2	1	4
3C25	2	2	1	4
3C29	1	2	1	-
3C10	2	2	1	4
3C7	2	2	1	4

4. Spool symbol "3C12" in the neutral position A → T
6. Spool symbol "3C10" in the neutral position B → T

04 Specification Working limits (The working limits for directional valves have determined by using solenoids at their operating temperature, 10% under voltage and with no pre-loading of the tank.)

4/2 valve Without detent					
Function code	Working pressure (MPa)				
	7	14	21	28	35
Flow (L/min)					
2B3	300	300	300	260	220
2B2	300	300	210	190	160

4/2 valve With detent					
Function code	Working pressure (MPa)				
	7	14	21	28	35
Flow (L/min)					
2B2 2B3	300	300	300	260	220

4/3 valve Without detent					
Function code	Working pressure (MPa)				
	7	14	21	28	35
Flow (L/min)					
3C2 3C3 3C4 3C12 3C9 3C29 3C10	300	300	300	300	300
3C5 3C25	300	300	210	190	170
3C6	300	300	220	210	180
3C7	300	260	200	180	170

4/3 valve With detent					
Function code	Working pressure (MPa)				
	7	14	21	28	35
Flow (L/min)					
3C2 3C3 3C4 3C12 3C9 3C29 3C10	300	300	300	300	300
3C5 3C25	300	300	280	230	230
3C6	300	300	230	230	230
3C7	300	300	250	230	230

06 Specification Working limits (The working limits for directional valve have determined using solenoids at their operating temperature, 10% under voltage and with no pre-loading of the tank.)

4/2 valve Without detent					
Function code	Working pressure (MPa)				
	7	14	21	28	35
Flow (L/min)					
2B3	450	300	250	200	180
2B2	350	300	275	250	200

4/2 valve With detent					
Function code	Working pressure (MPa)				
	7	14	21	28	35
Flow (L/min)					
2B3 2B2	450	450	450	450	450

4/3 valve Without detent					
Function code	Working pressure (MPa)				
	7	14	21	28	35
Flow (L/min)					
3C2 3C3 3C4 3C12 3C9 3C29 3C10	450	450	450	450	450
3C5	450	250	200	135	110
3C6	450	330	290	230	180
3C3	450	450	400	400	350
3C25	450	310	240	215	150
3C7	450	310	280	270	200

4/3 valve With detent					
Function code	Working pressure (MPa)				
	7	14	21	28	35
Flow (L/min)					
3C2 3C5 3C6 3C3 3C4 3C10 3C9 3C25 3C29 3C12	450	450	450	450	450
3C7	450	450	400	350	300

Manual Operated Directional Control Valve

10 Specification Performance curve (Measured at $v=41\text{mm}^2/\text{s}$ and $t=50^\circ\text{C}$)

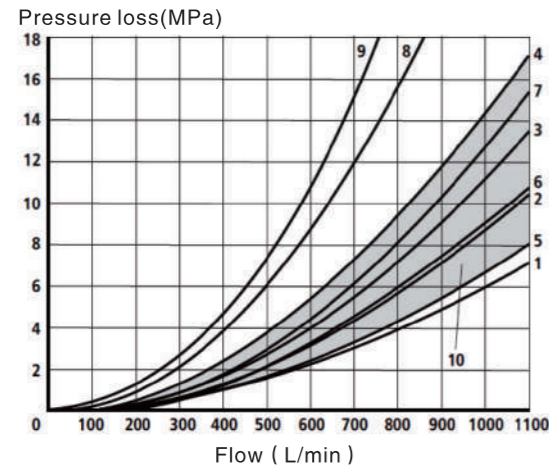

Function code	Direction				
	P→A	P→B	A→T	B→T	P→T
3C2	1	1	2	3	-
3C6	6	5	6	7	7
3C29	1	1	2	-	4

10 All other spool types

Manual Operated Directional Control Valve

02 External dimensions

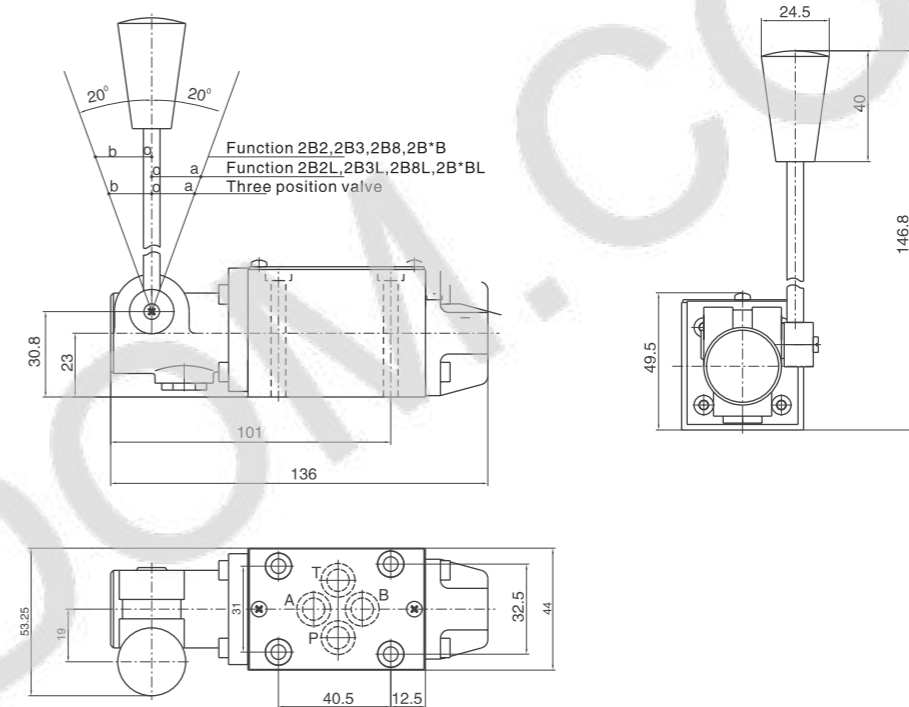

10 Specification Working limits (The working limits for directional valves have determined by using solenoids at their operating temperature, 10% under voltage and with no pre-loading of the tank.)

4/2 valve Without detent					
Function code	Working pressure (MPa)				
	7	14	21	28	35
Flow (L/min)					
2B3	1100	1040	860	800	700
2B2	1100	1040	540	480	420

4/2 valve With detent					
Function code	Working pressure (MPa)				
	7	14	21	28	35
Flow (L/min)					
2B3 2B2	1100	1040	860	750	680

4/3 valve Without detent					
Function code	Working pressure (MPa)				
	7	14	21	28	35
Flow (L/min)					
3C2 3C3 3C4 3C12 3C9 3C29 3C10	1100	1040	860	750	680
3C5	900	900	800	650	450
3C6	900	900	800	650	450
3C3	900	900	800	650	450
3C25	900	900	800	650	450
3C7	1100	1100	680	500	450

4/3 valve With detent					
Function code	Working pressure (MPa)				
	7	14	21	28	35
Flow (L/min)					
3C2 3C5 3C6 3C3 3C4 3C10 3C9 3C25 3C12	1100	1040	860	750	680
3C7	1100	1040	860	750	680

02 Size of subplate oil port

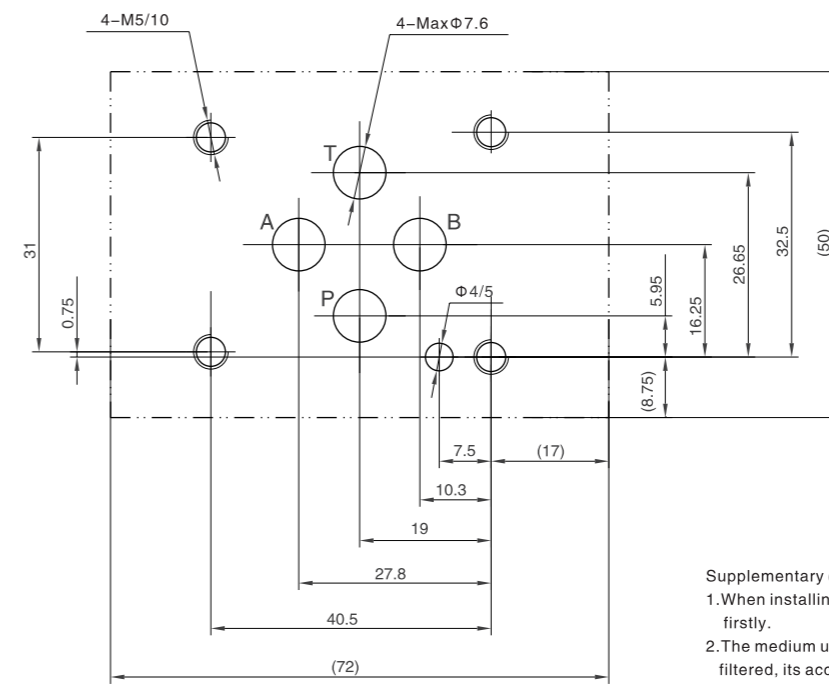

Mounting screw	Amount	Tighten torque
M5x50-10.9	4	9Nm

Supplementary explanation

- When installing the product, considering horizontal position firstly.
- The medium used in the hydraulic system must be filtered, its accuracy is at least $20\mu\text{m}$.
- Screw should be according to the parameters in catalogue.
- The surface, connecting with the valve, should be Ra0.8 roughness, and 0.01/100mm flatness.

Manual Operated Directional Control Valve

03 Spring type external dimensions

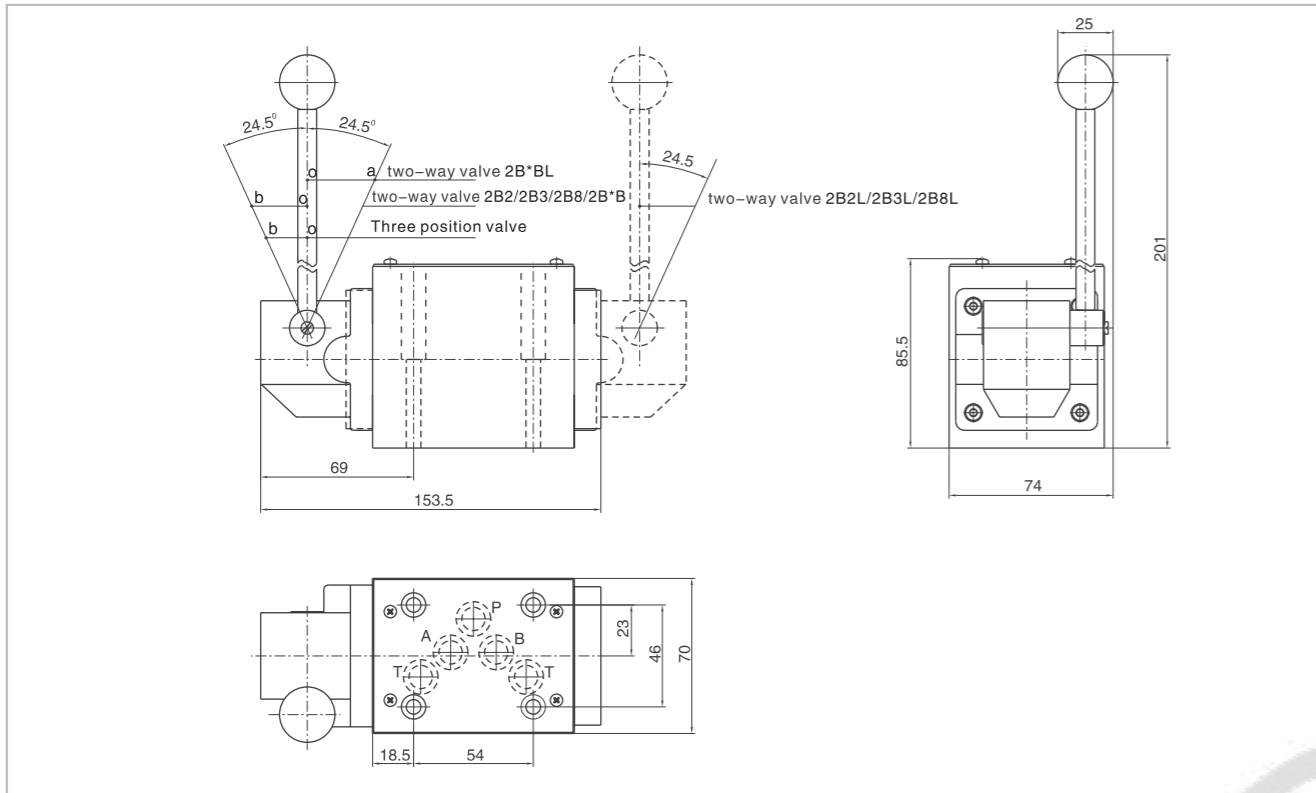

Manual Operated Directional Control Valve

03 With detent type external dimensions

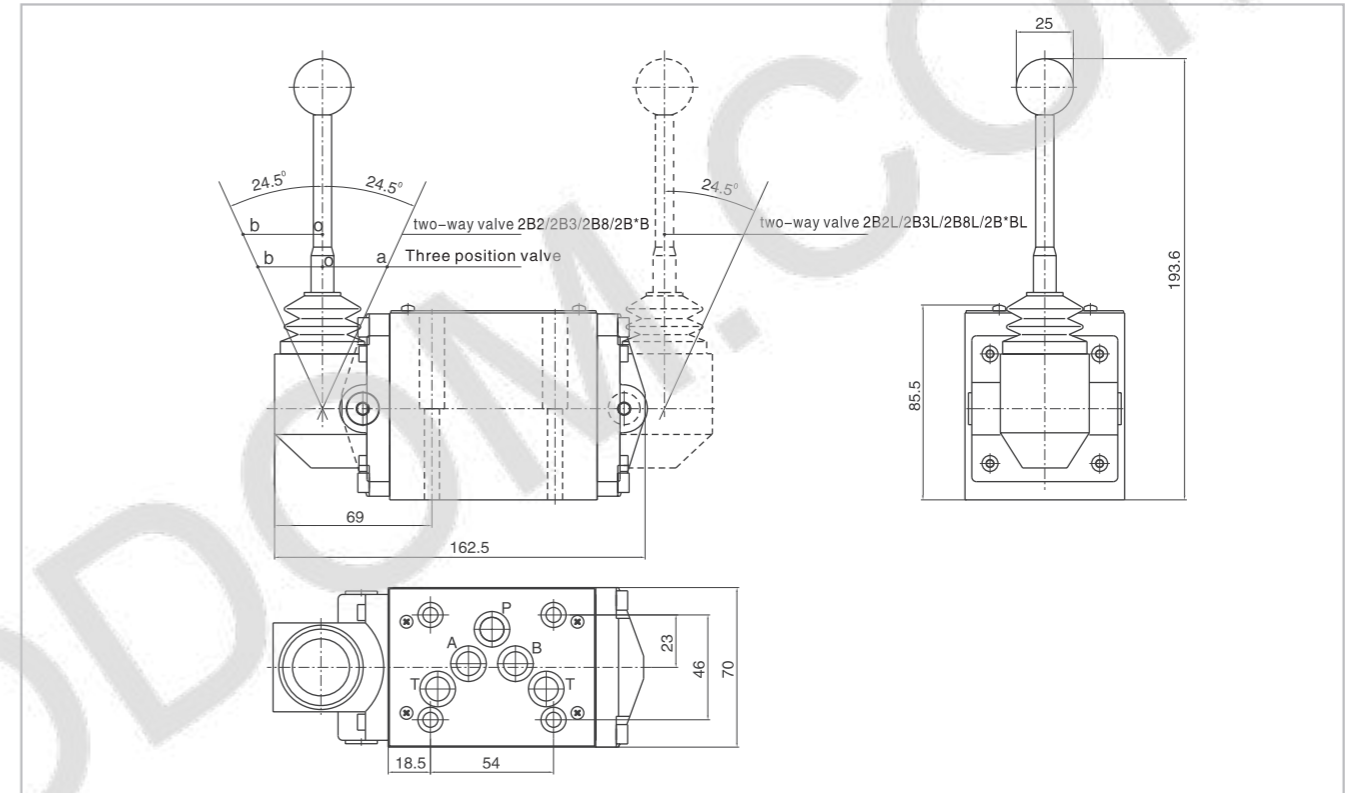

03 Spring type size of subplate oil port

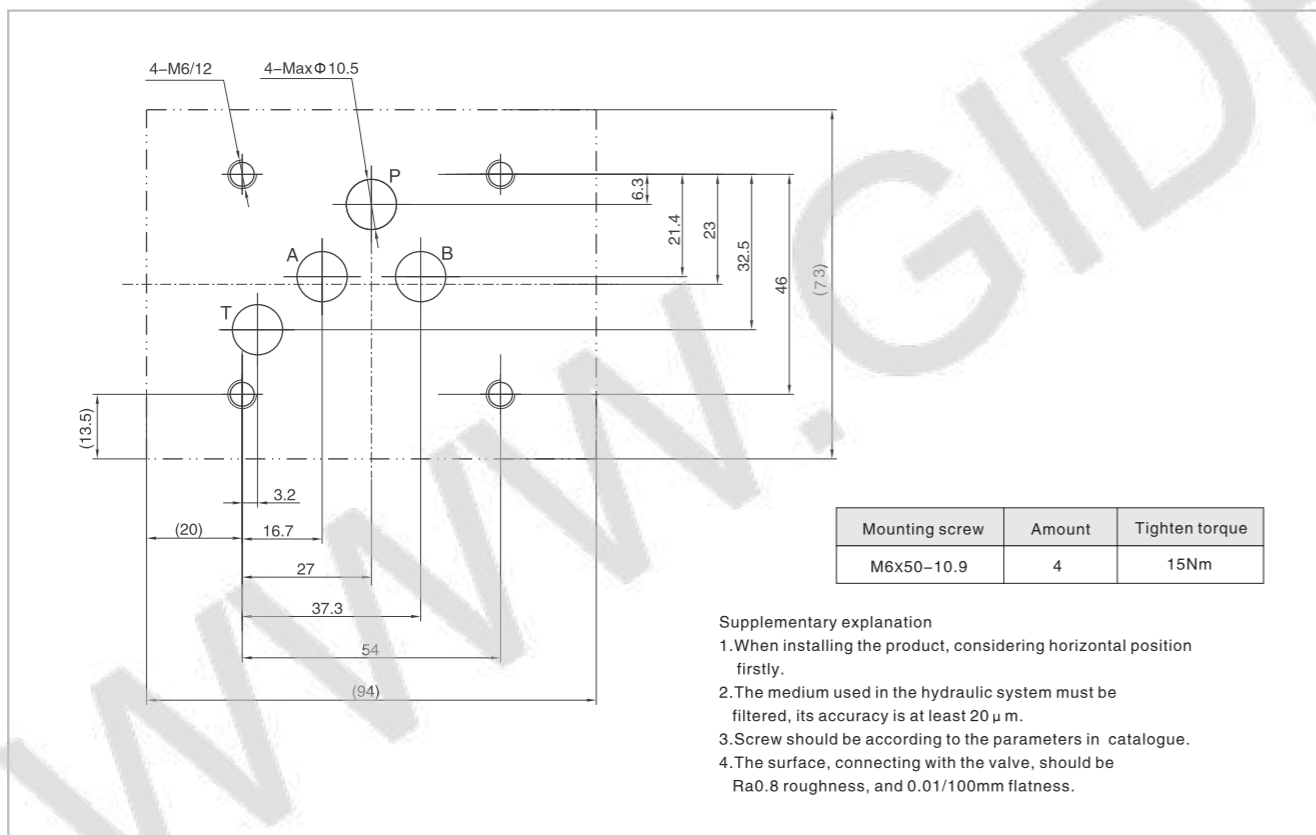

03 With detent type size of subplate oil port

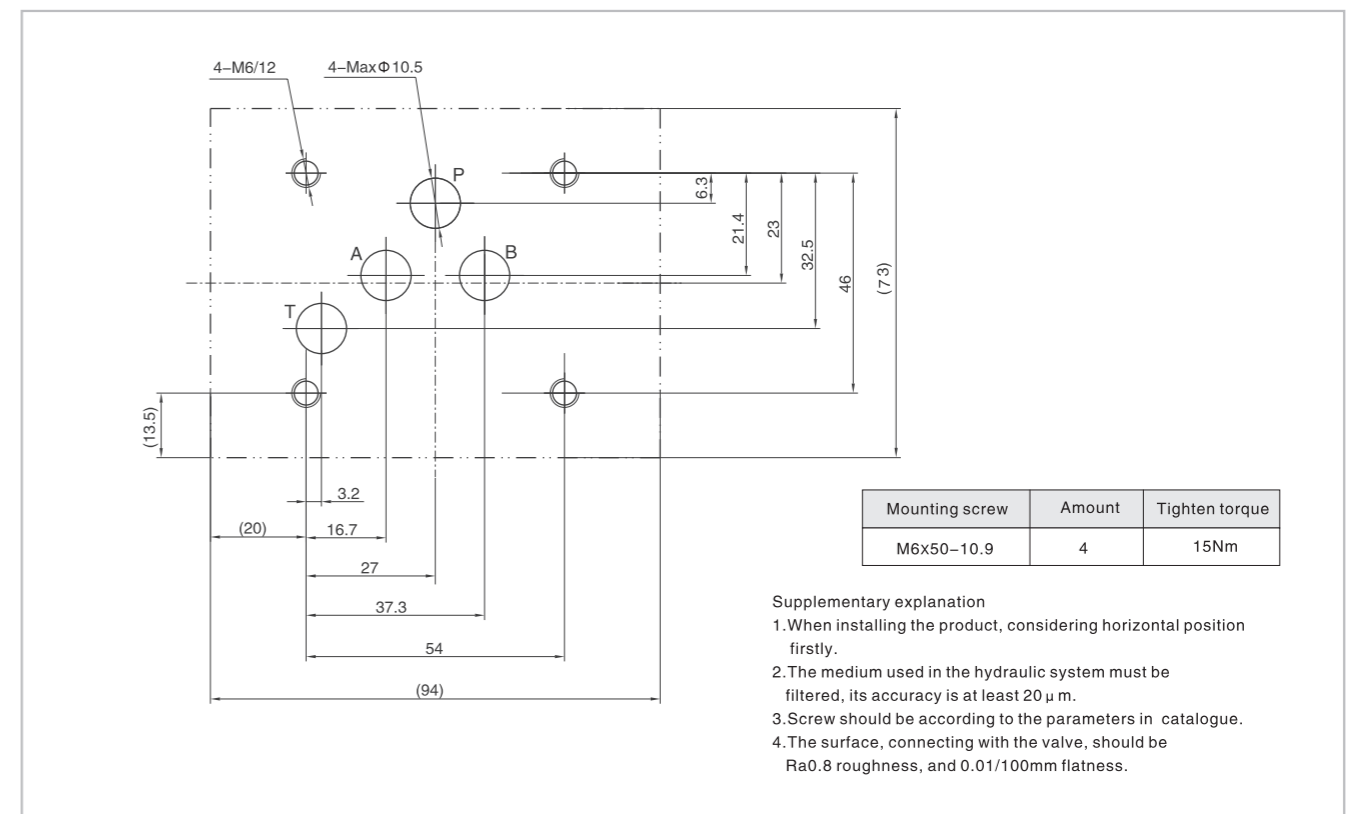

Manual Operated Directional Control Valve

04 External dimensions

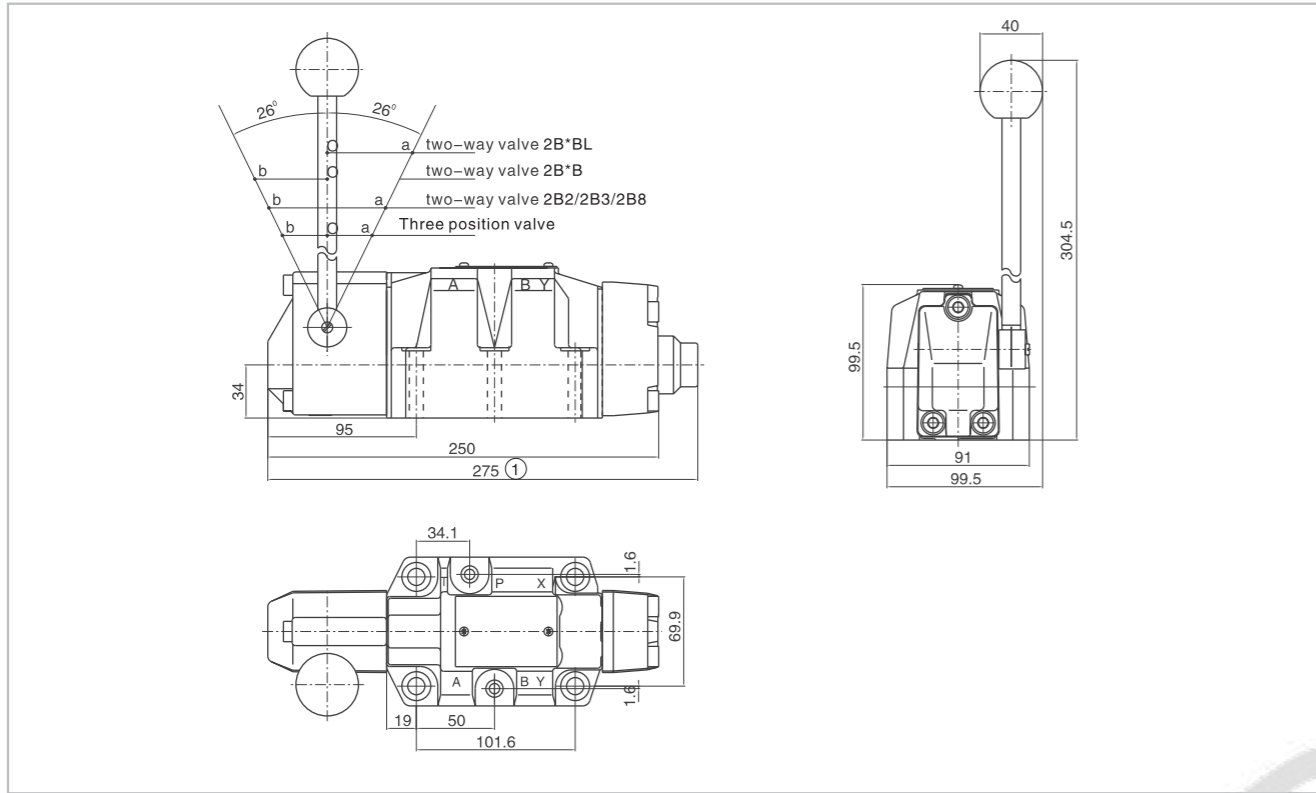

D.7.12

Manual Operated Directional Control Valve

06 External dimensions

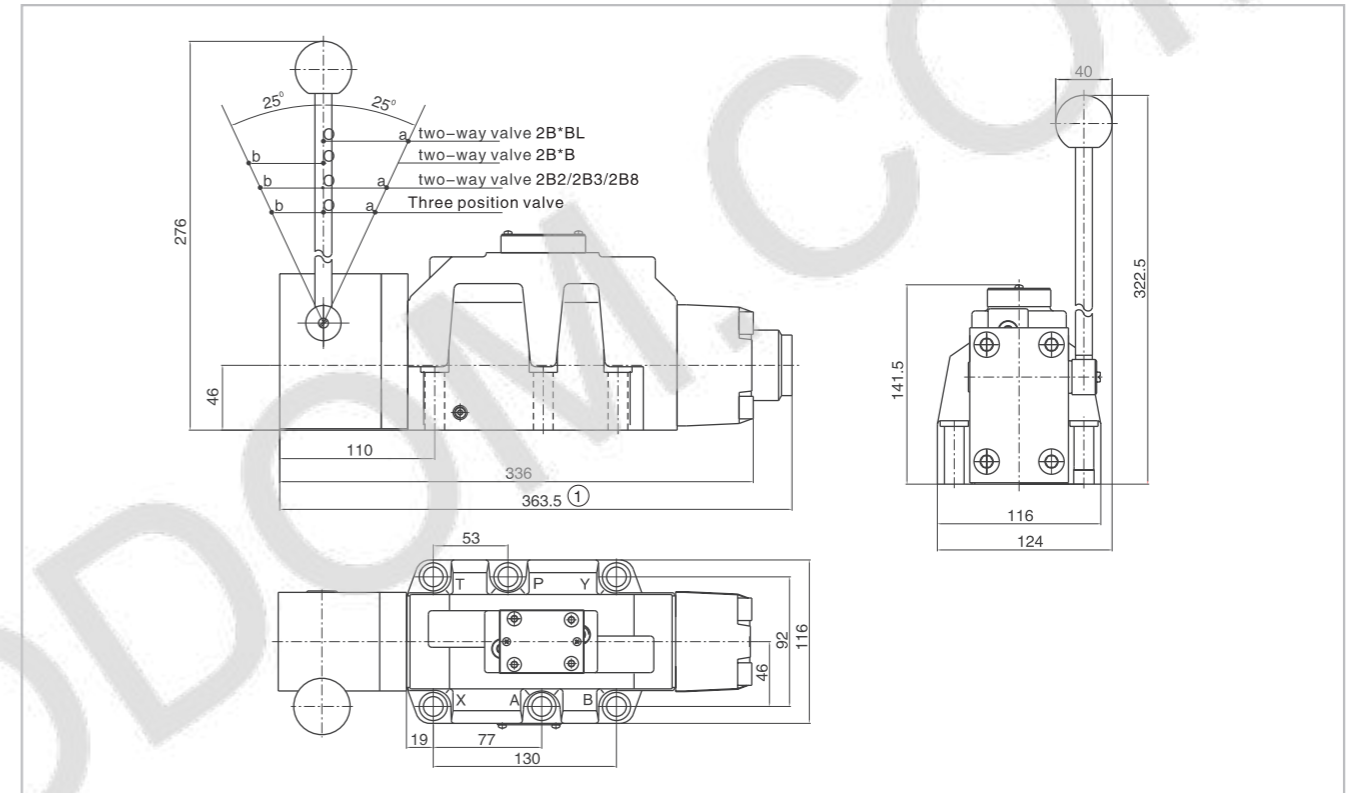

D.7.13

04 Size of subplate oil port

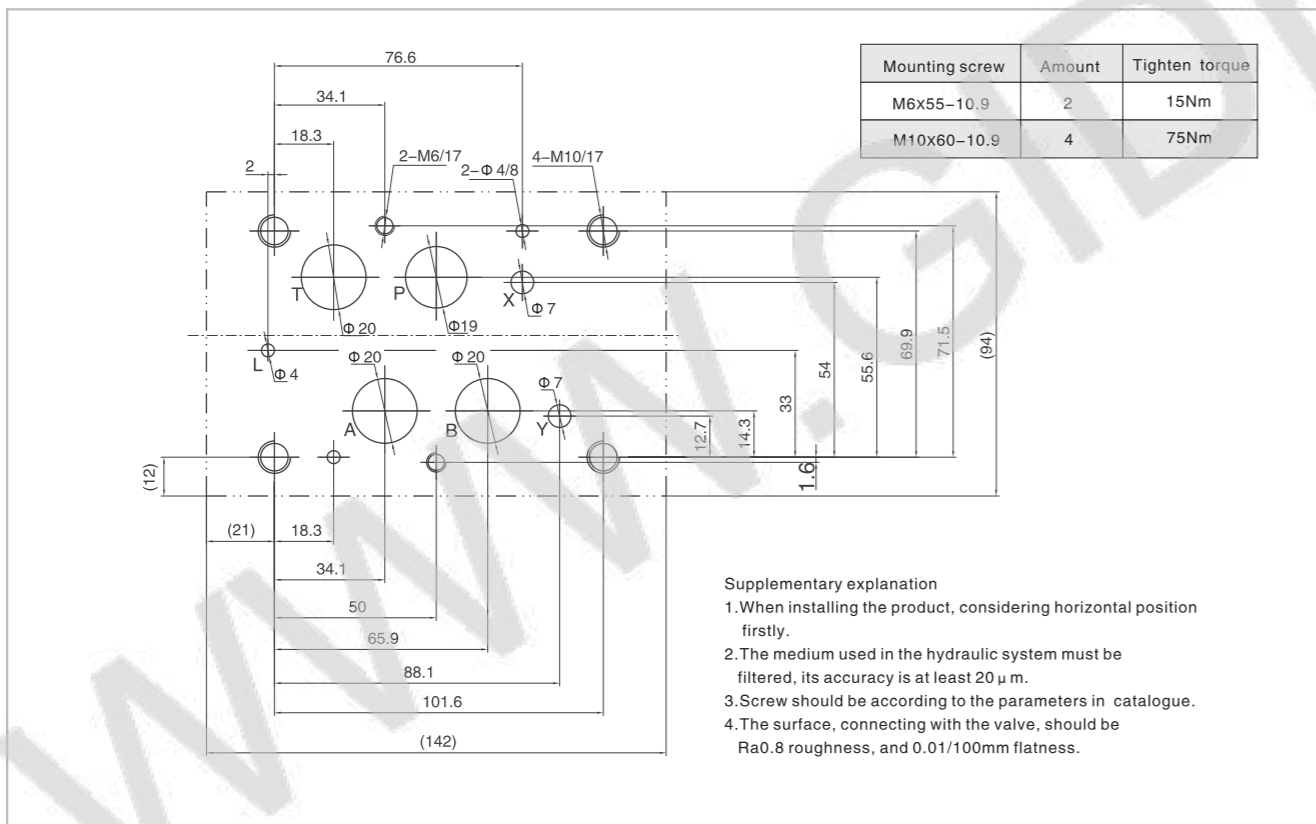

D.7.12

06 Size of subplate oil port

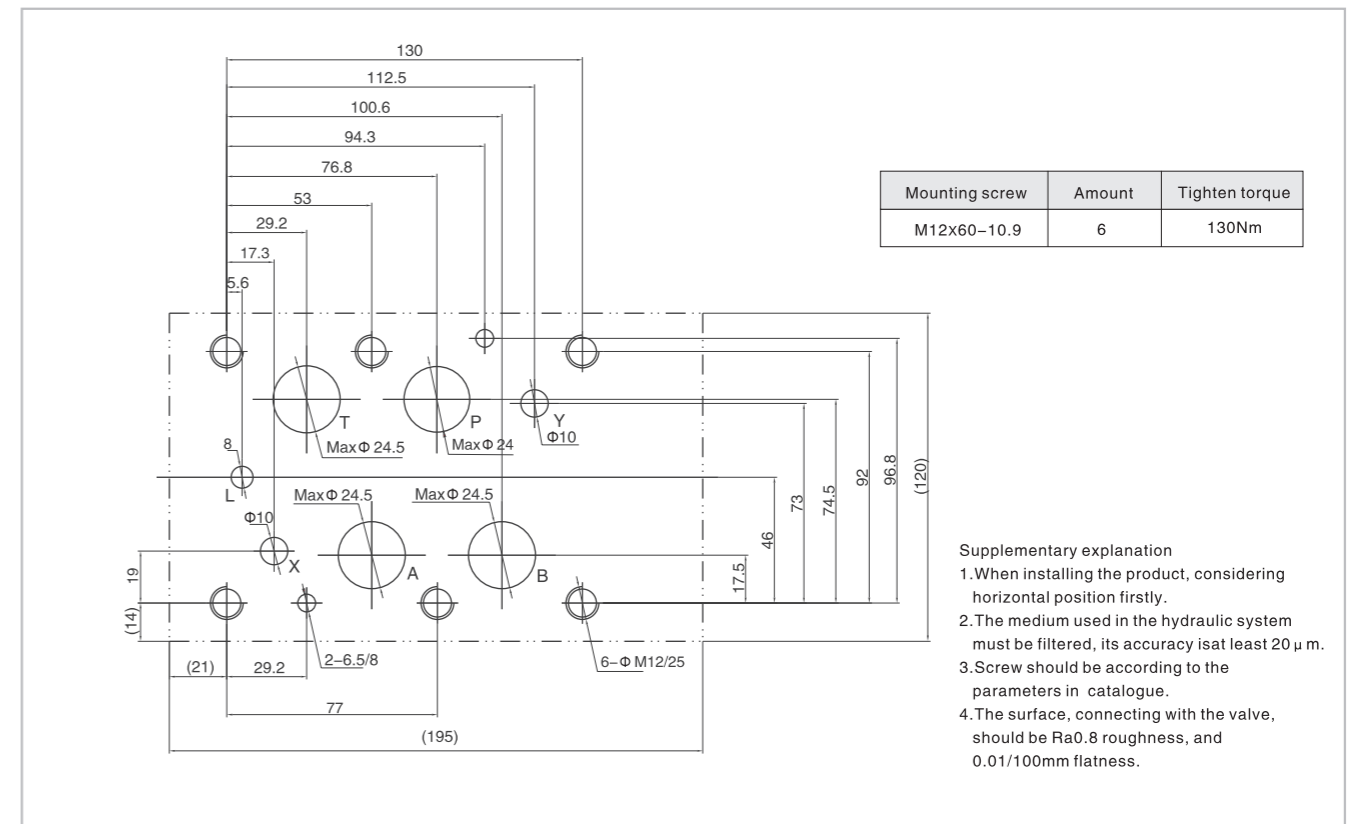

D.7.13

Manual Operated Directional Control Valve

10 External dimensions

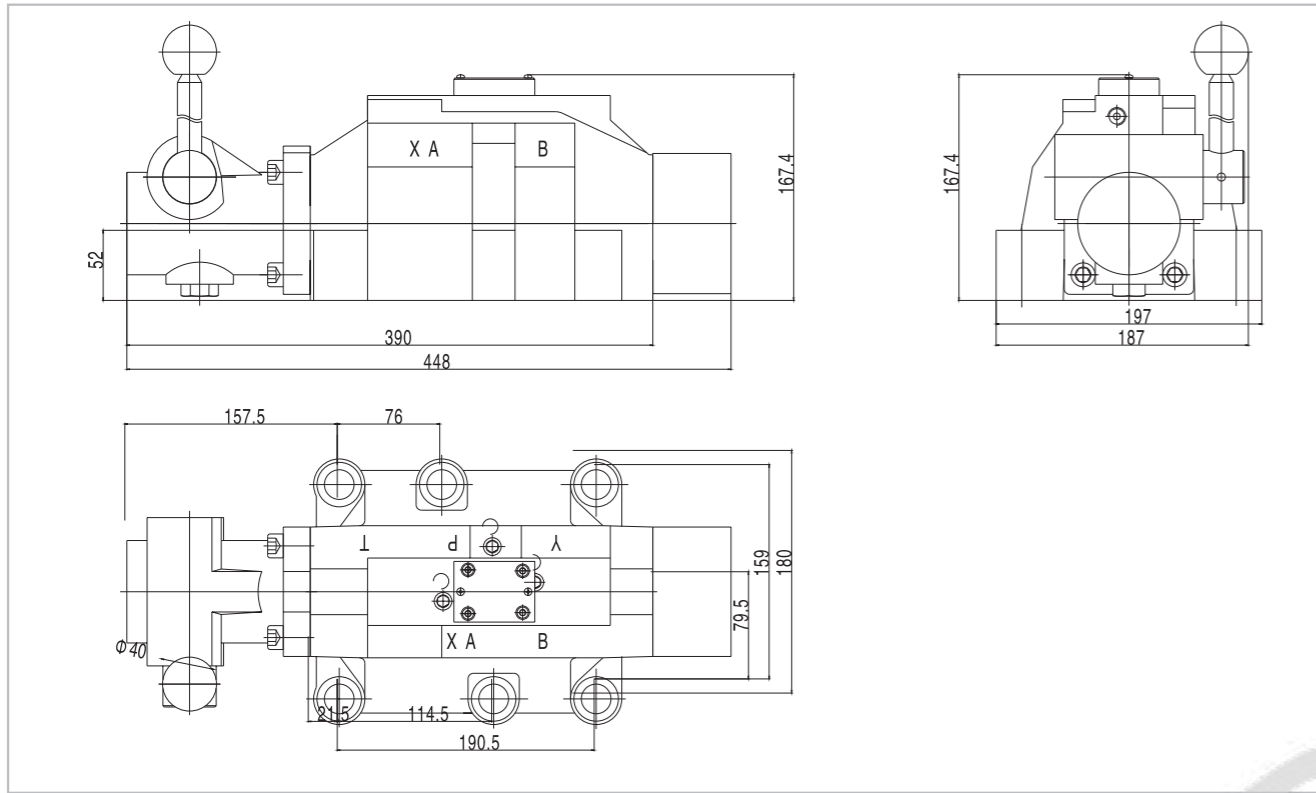

10 Size of subplate oil port

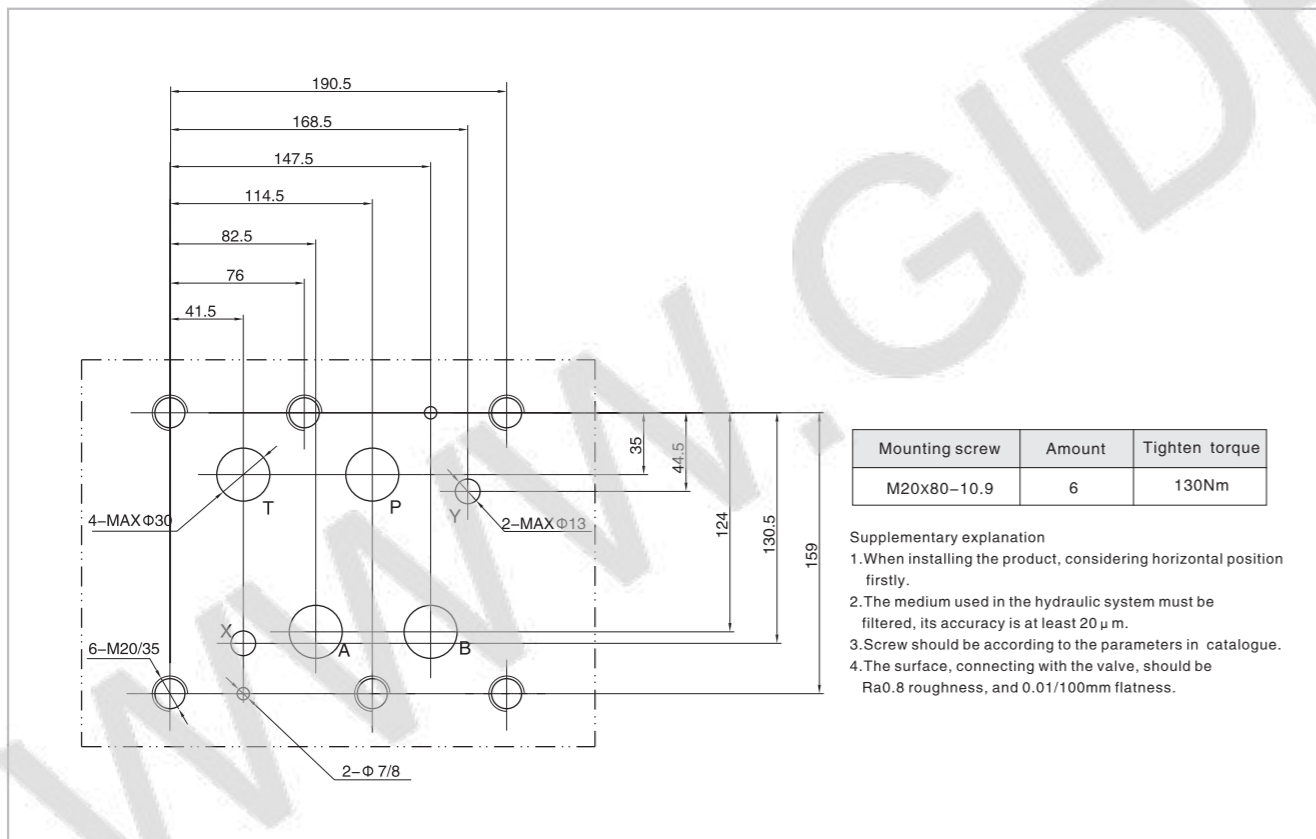

Hydraulic-operated Directional Control Valve

Parameter



Model		02
Working pressure (MPa)	Oil port P, A, B	31.5
	Oil port T	16
Max flow rate (L/min)		60
Working fluid	Mineral oil; Phosphate oil	
Fluid temp (°C)	-20~70	
Cleanliness	NAS1638 Class 9, recommended filtration precision Min β ₁₀ ≥ 75.	

(Please consult us if your application is over above data)

The spool inside the valve FH-02 is driven by hydraulic control oil, so that to change the fluid direction.

Ordering code

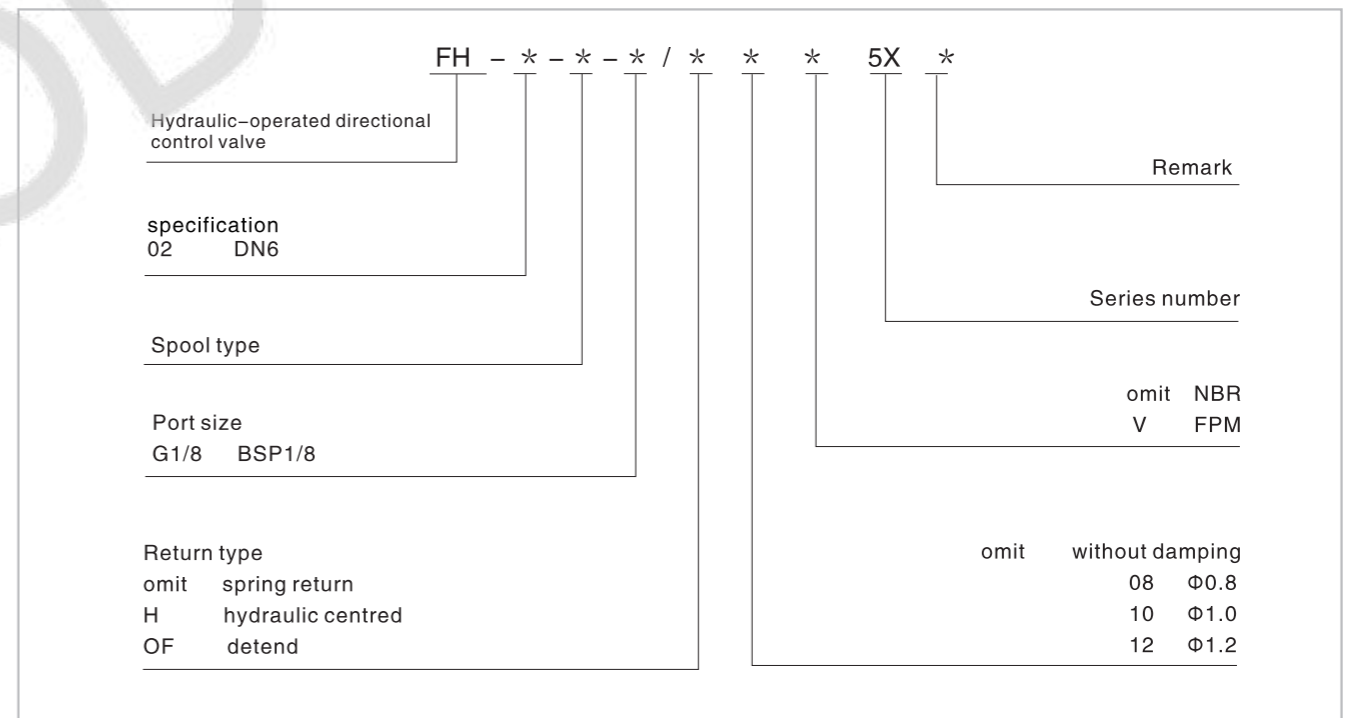

The name of control oil port

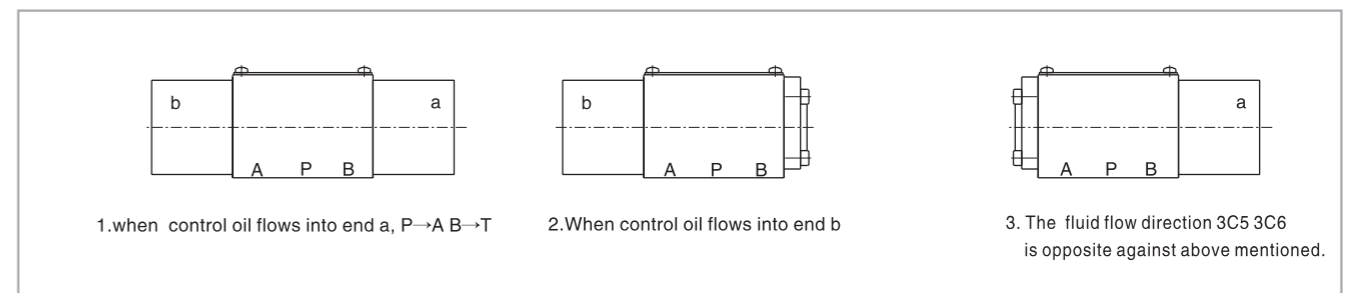

Hydraulic-operated Directional Control Valve

Spool type

Spring-return

3C2		2B2B		2B2BL	
3C3		2B3B		2B3BL	
3C4		2B4B		2B4BL	
3C5		2B5B		2B5BL	
3C6		2B6B		2B6BL	
3C7		2B7B		2B7BL	
3C9		2B9B		2B9BL	
3C10		2B10B		2B10BL	
3C11		2B11B		2B11BL	
3C12		2B12B		2B12BL	
3C25		2B25B		2B25BL	
3C29		2B29B		2B29BL	

Note: *D* (without spring-return without detent), the valve shall be mounted in horizontal direction.

2B2	
2B3	
2B8	

2B2L	
2B3L	
2B8L	

With detent

	2D2
	2D3
	2D8

Without spring-return without detent

	2N2
	2N3
	2N8

Hydraulic-operated Directional Control Valve

Dimension

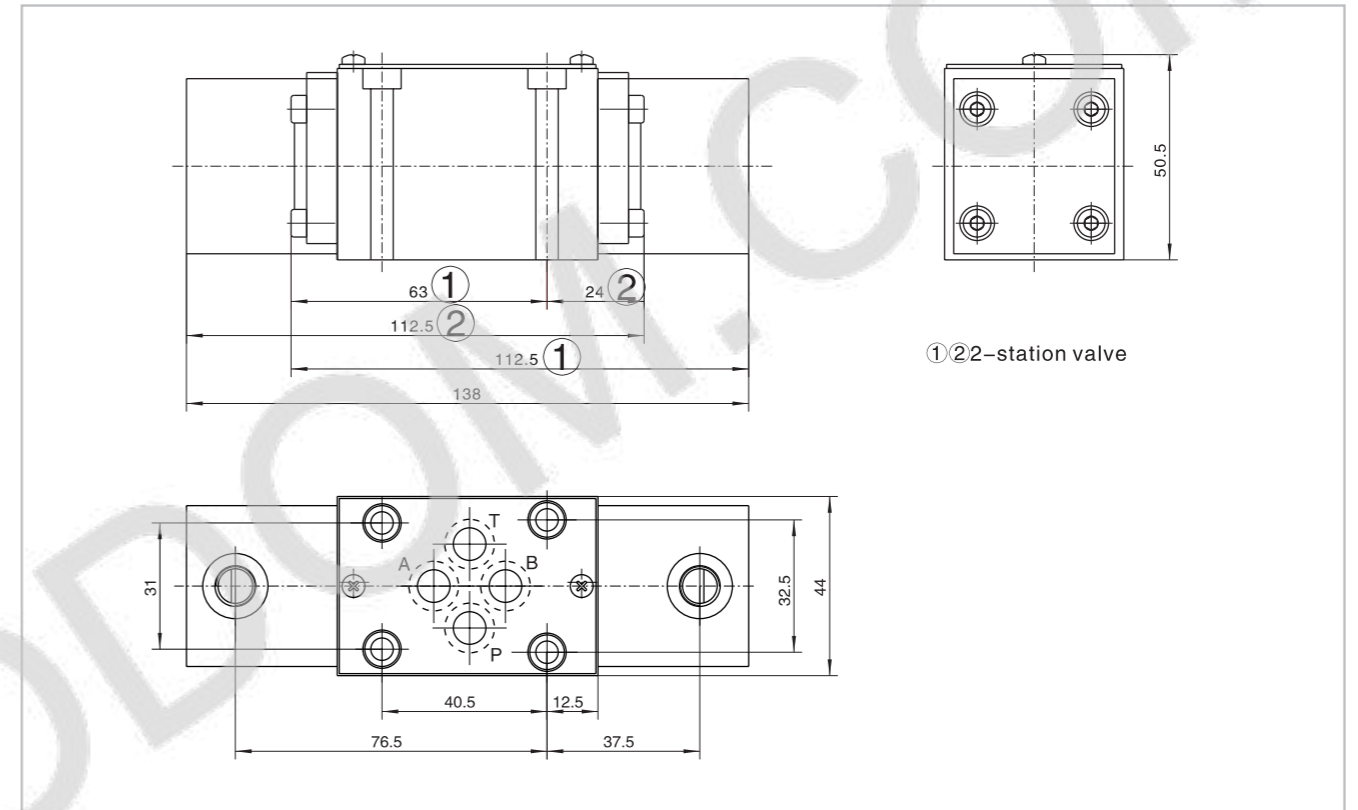

Subplate size

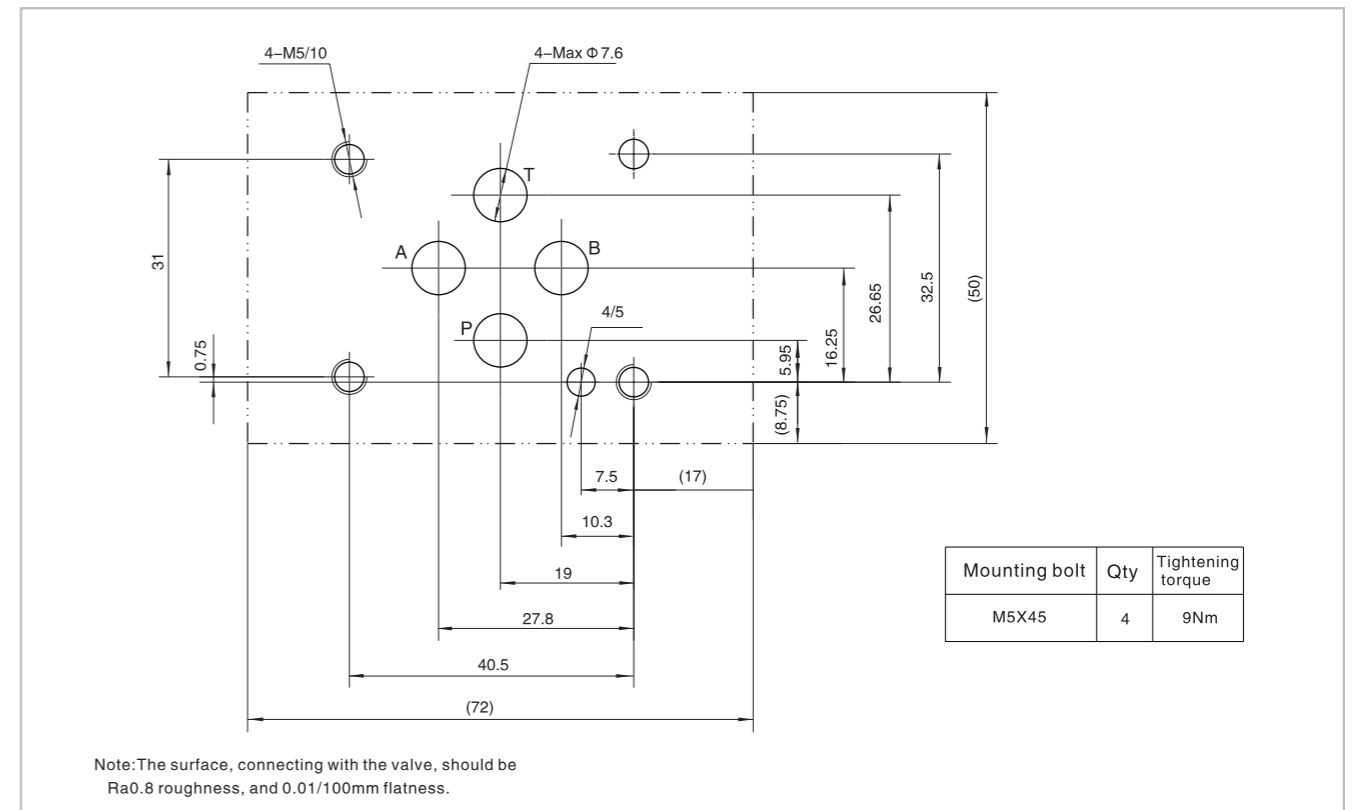

Note: The surface, connecting with the valve, should be Ra0.8 roughness, and 0.01/100mm flatness.

Water-proof Electrical Operated Directional Control Valve

Technical specification



Specification		02
Working pressure (MPa)	Oil ports P, A, B	31.5
	Oil port T	10
Max. Flow (L/min)		80
Working fluid	Mineral oil; phosphate-ester	
Fluid temp. (°C)	-20~70	
Viscosity (mm ² /s)	2.8~380	
Working voltage (V)	DC 12	24
Max. Switch frequency (T/h)	15000	
Insulation grade	Ip65	
Cleanliness	The maximum allowable cleanliness of the oil should be according to 9th degree of Standard NAS1638. It is suggested that the minimum filter rating should be $\beta_{10} \geq 75$.	

Water-proof electrical operated directional control valve uses solenoid to pull the spool and change the direction of the hydraulic oil.

Water-proof electrical operated directional control valve can directly control the start, stop and direction of a fluid flow. It also can be used as the pilot-operated valve, which could operate other valves.

Supplement: Water-proof electrical operated directional control valve is usually used at damp environment such as garbage trucks.

Model description

Water-proof electrical operated directional control valve	W P F W	-	*	-	*	-	*	/	*	*	5 X	*	Remarks
Specification	02 DN6												Serial number
	03 DN10												Seal material
Function code	Details as following symbol table												Omit NBR Seals
													V FPM Seals
Working voltage	D12 DC12V												Omit without damping
	D24 DC24V												08 Φ 0.8 Damping
													10 Φ 1.0 Damping
													12 Φ 1.2 Damping
													Omit without hand emergency
													N9 with concealed hand emergency

Water-proof Electrical Operated Directional Control Valve

Code symbol

Spring return

3C2		2B2B		2B2BL		2B2	
3C3		2B3B		2B3BL		2B3	
3C4		2B4B		2B4BL		2B4	
3C5		2B5B		2B5BL		2B5	
3C6		2B6B		2B6BL		2B6	
3C7		2B7B		2B7BL		2B7	
3C9		2B9B		2B9BL		2B9	
3C10		2B10B		2B10BL		2B10	
3C11		2B11B		2B11BL		2B11	
3C12		2B12B		2B12BL		2B12	
3C25		2B25B		2B25BL		2B25	
3C29		2B29B		2B29BL		2B29	

Water-proof Electrical Operated Directional Control Valve

Name of solenoid

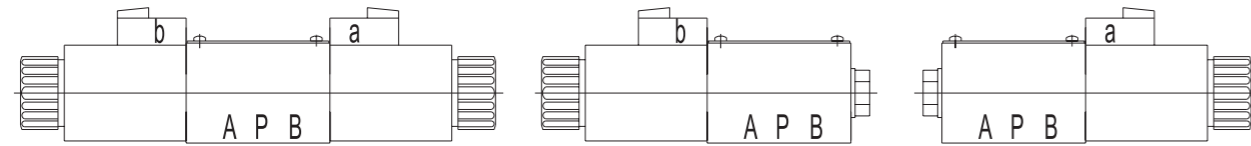

1. a When movement a, P→A B→T
2. b When movement b, P→B A→T
3. 3C5,3C6 Oil flow in the opposite direction with the above-mentioned movement.

Specification Performance curve (Measured at $v=41\text{mm}^2/\text{s}$ and $t=50^\circ\text{C}$)

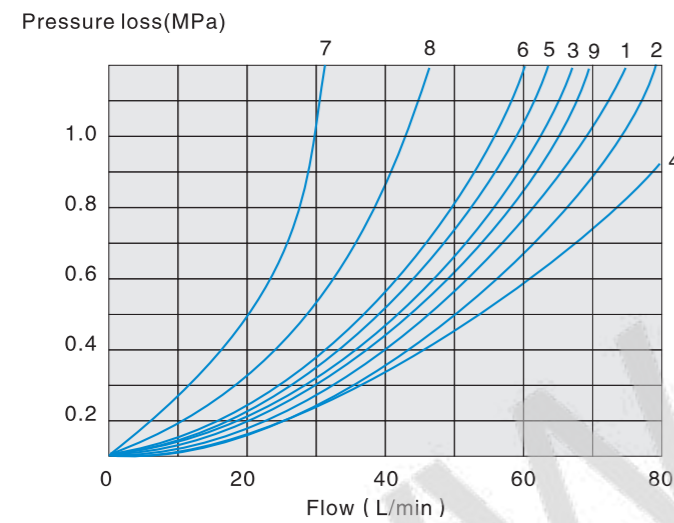

Function code	Direction			
	P→A	P→B	A→T	B→T
2B8 2B8L	3	3	-	-
2B3	1	1	3	1
2B2 2B2L	5	5	3	3
3C2	3	3	1	1
3C5	1	3	1	1
3C6	6	6	9	9
3C3	2	4	2	2
3C4	1	1	2	1
3C10 3C12	3	3	4	9
3C9	2	3	3	3
C25	3	1	1	1
3C29	5	5	4	-
3C7	1	2	1	1

7. Spool type "3C29" located in the control position A → B
8. Spool symbol 3C6 in the median position P → T

Water-proof Electrical Operated Directional Control Valve

Specification Working limits (The working limits for directional valve have determined by using solenoids at their operating temperature, 10% under voltage and with no pre-loading of the tank.)

With regard to the four-way valve, the normal flow data as shown is get from the regular use of two directions of the flow (e.g.P to A, and simultaneous return flow from B to T). See tables.
If only one flow direction is needed, for example: When a four port valve which is closed up port A or port B, used as a three-way valve, the Maximum flow may be very small in the serious condition.

DC solenoid operation DC D24, D1 2, B220, B110		AC solenoid operation AC A110, A220, 50HZ	
Curve	Symbol	Curve	Symbol
1	2B8 2B8L1)	11	2B8 2B8L1)
2	3C7	12	3C7
3	2B8 2B8L	13	2B8 2B8L
4	3C5 3C25	14	3C5 3C25
5	3C4	15	3C6
6	3C6 3C3	16	3C3
7	2N8 2D8 3C10 3C12	17	2N8 2D8 2N3 2D3
8	2B3 2B2 2B2L	18	2N2 2D2 3C2 3C4 3C10
9	3C9		3C9 3C29 3C12
10	3C2 3C29 2N3 2D3 2N2 2D2		2B3 2B2 2B2L

Working pressure(MPa)

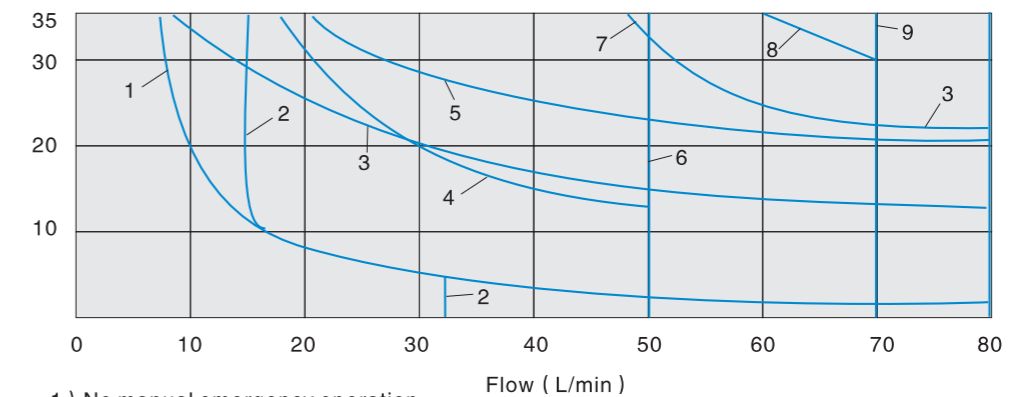

- 1) No manual emergency operation
- 2) Oil return from actuator to oil tank

Working pressure(MPa)

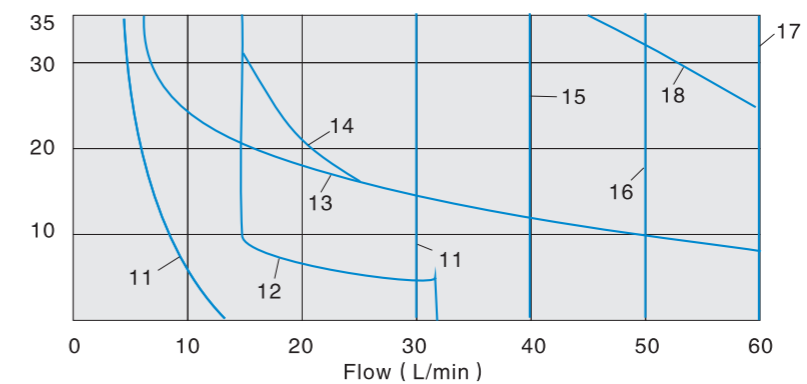

Water-proof Electrical Operated Directional Control Valve

External dimensions

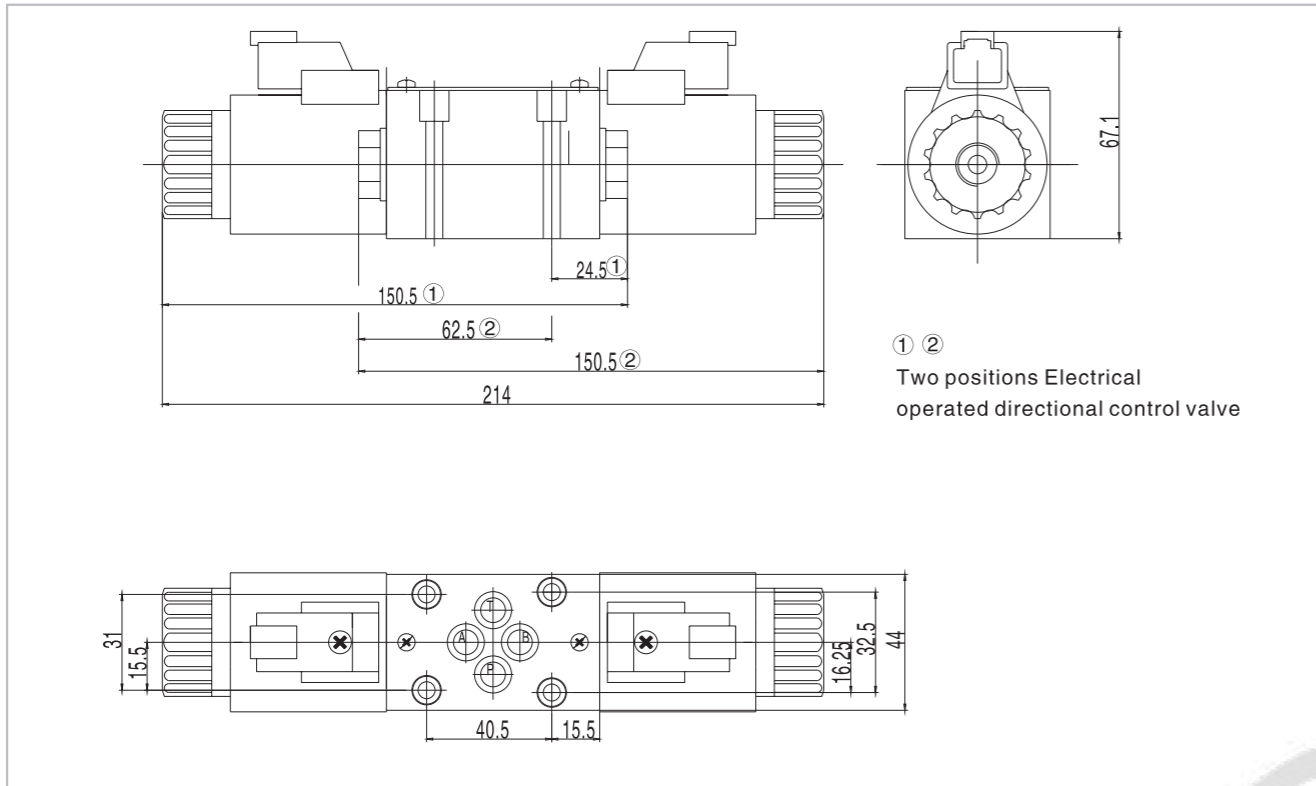

Size of subplate oil port

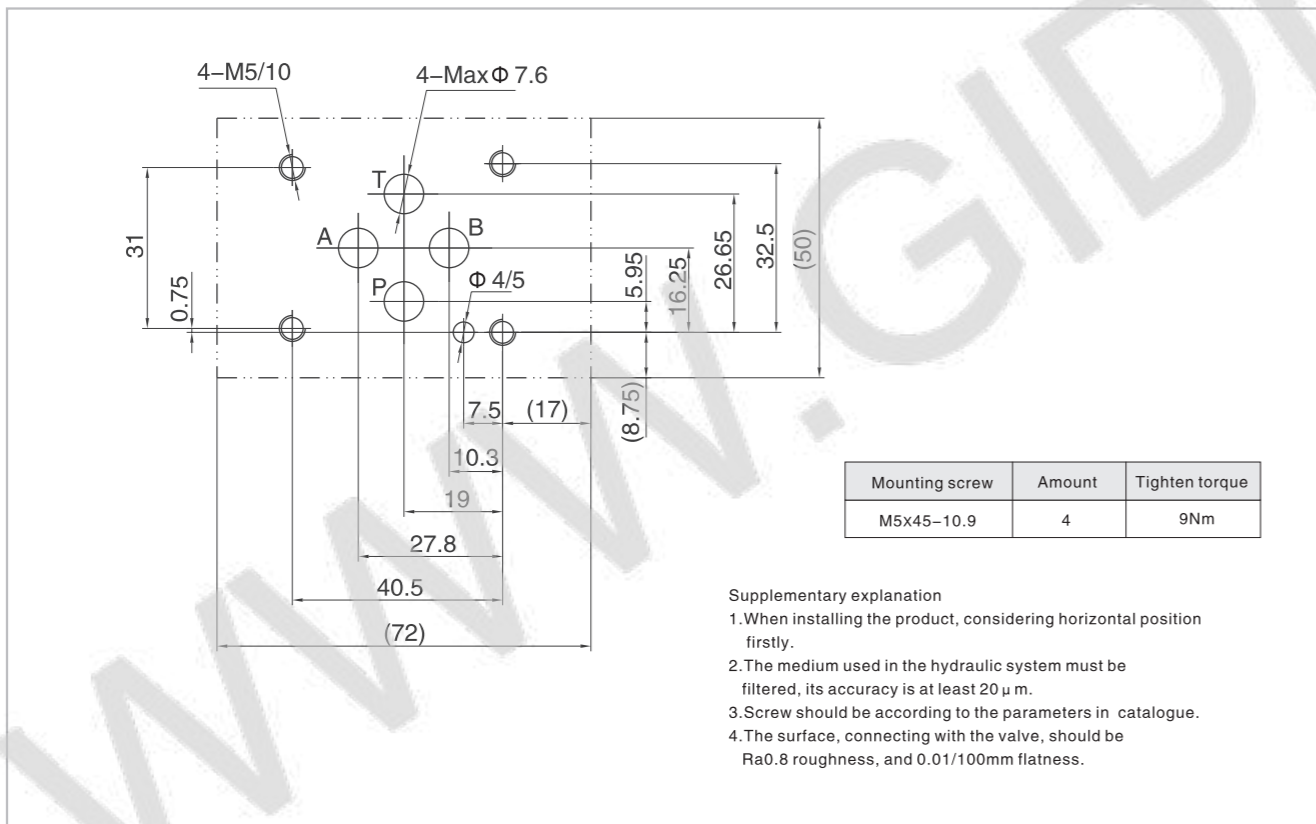

Water-proof Electrical Operated Directional Control Valve

External dimensions

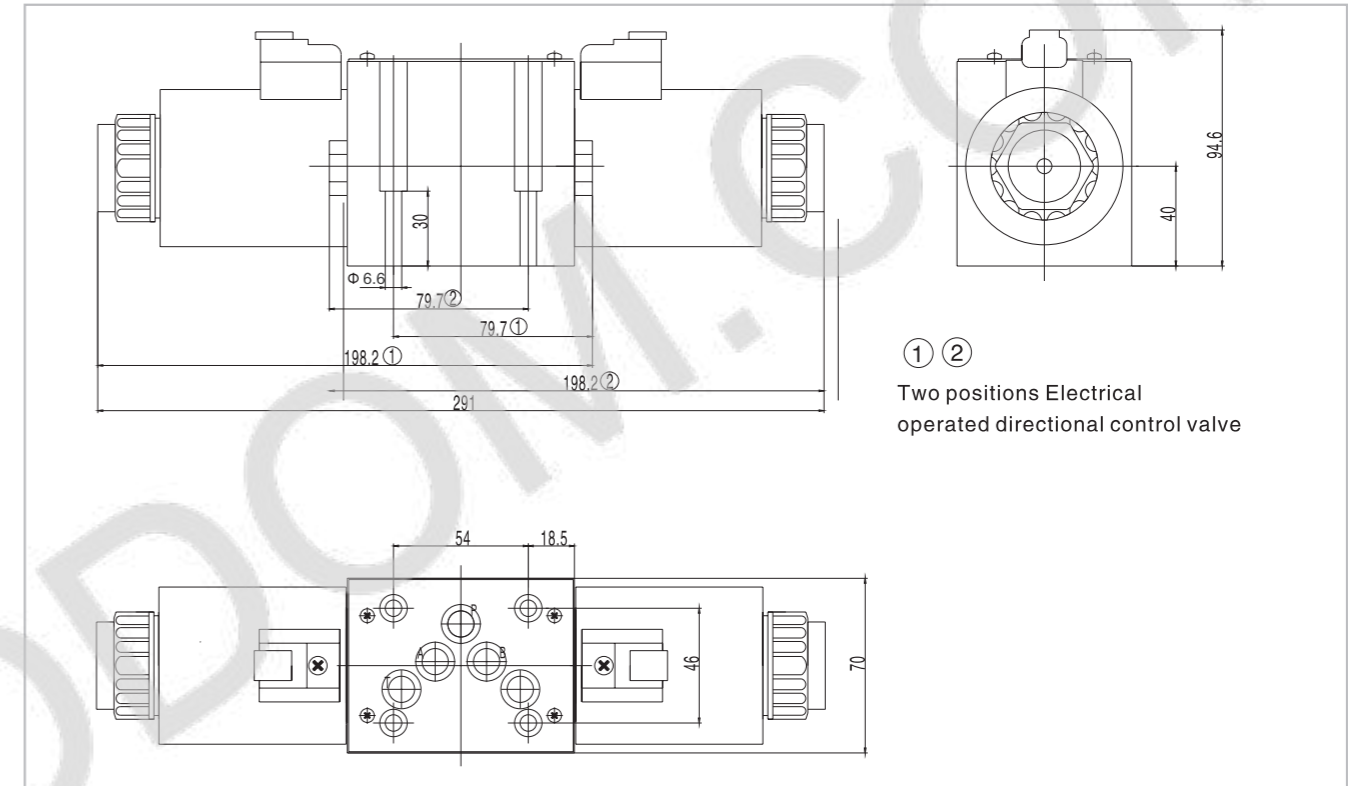

Size of subplate oil port

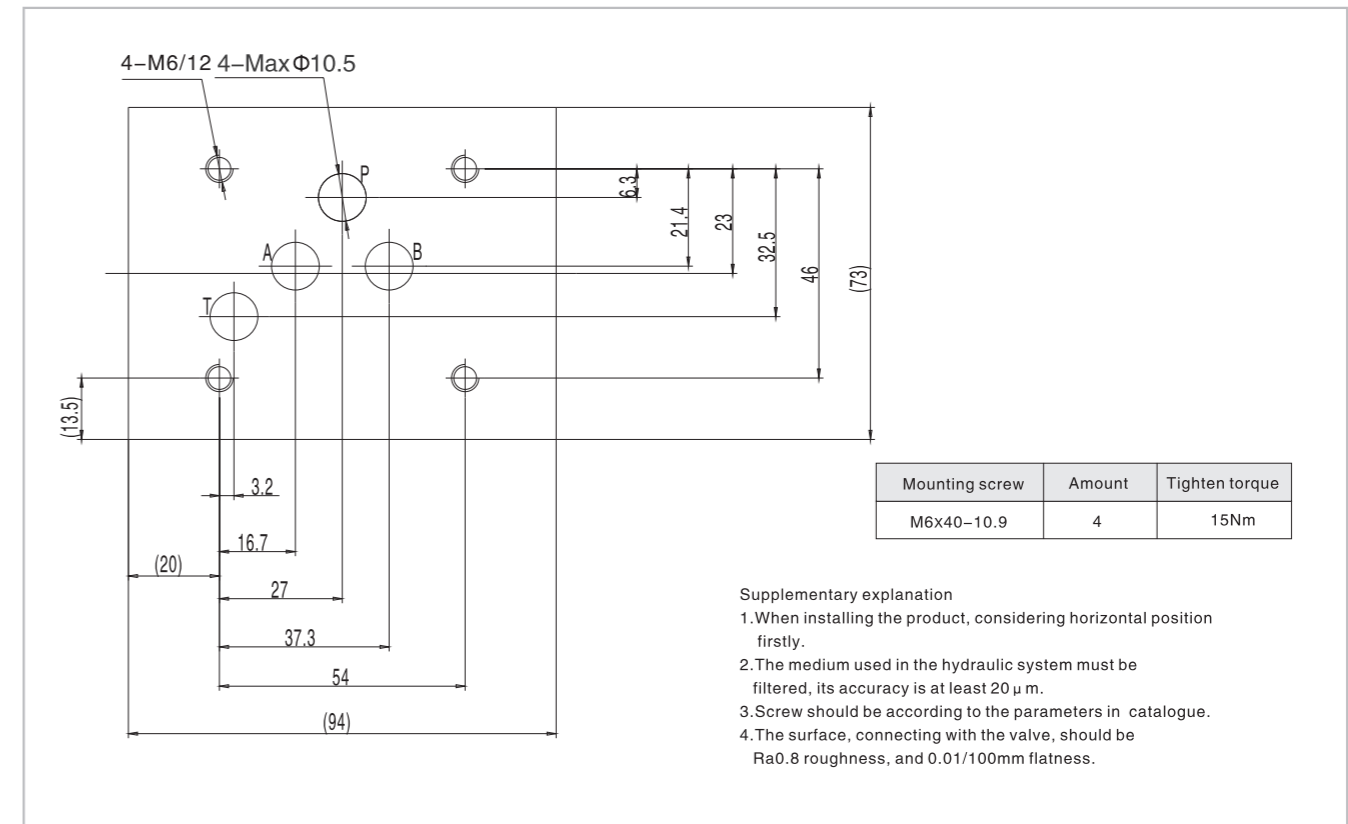

Solenoid Valve With Hand Control

Technical data



Model		02	03
Pressure range (MPa)	Oil port P, A, B	35	31.5
	Oil port T	10	
Max flow rate(L/min)		80	120
Installation	Any, recommended horizontal installation		
Working fluid	Mineral hydraulic oil; phosphate ester hydraulic oil		
Fluid temp (°C)	-20~70		
Fluid viscosity (mm ² /s)	2.8~100		
Working voltage (V)	DC	12	24
	AC	110/50Hz	220/50Hz
Protection grade	IP65		
Cleanliness	NAS1638 Class 9, recommended filtration precision Min β ₁₀ ≥ 75 ₀		

FWS can work as standard solenoid directional valve, also can control the spool movement with hand level on power-off condition.

Model description

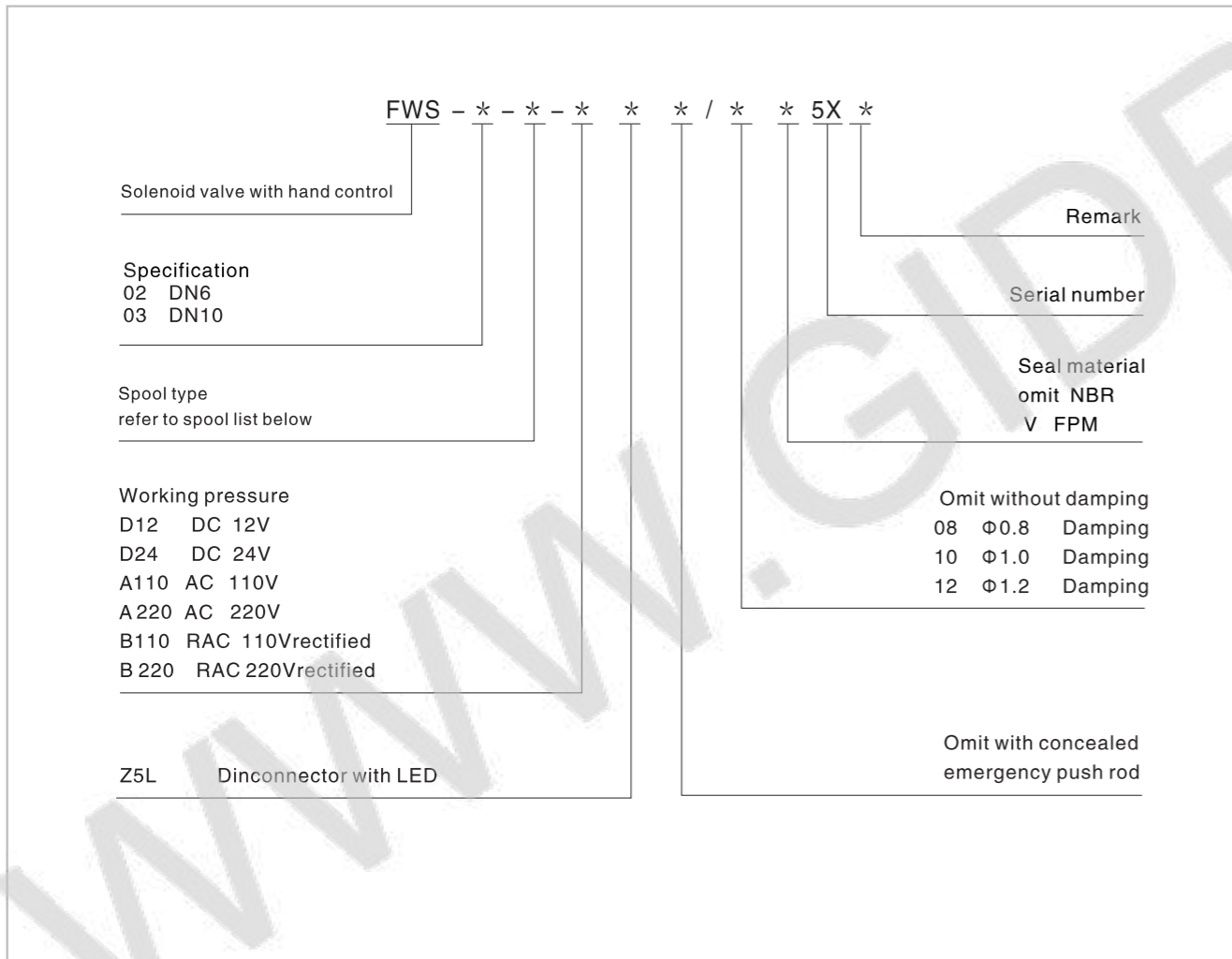

Solenoid Valve With Hand Control

02 Dimension

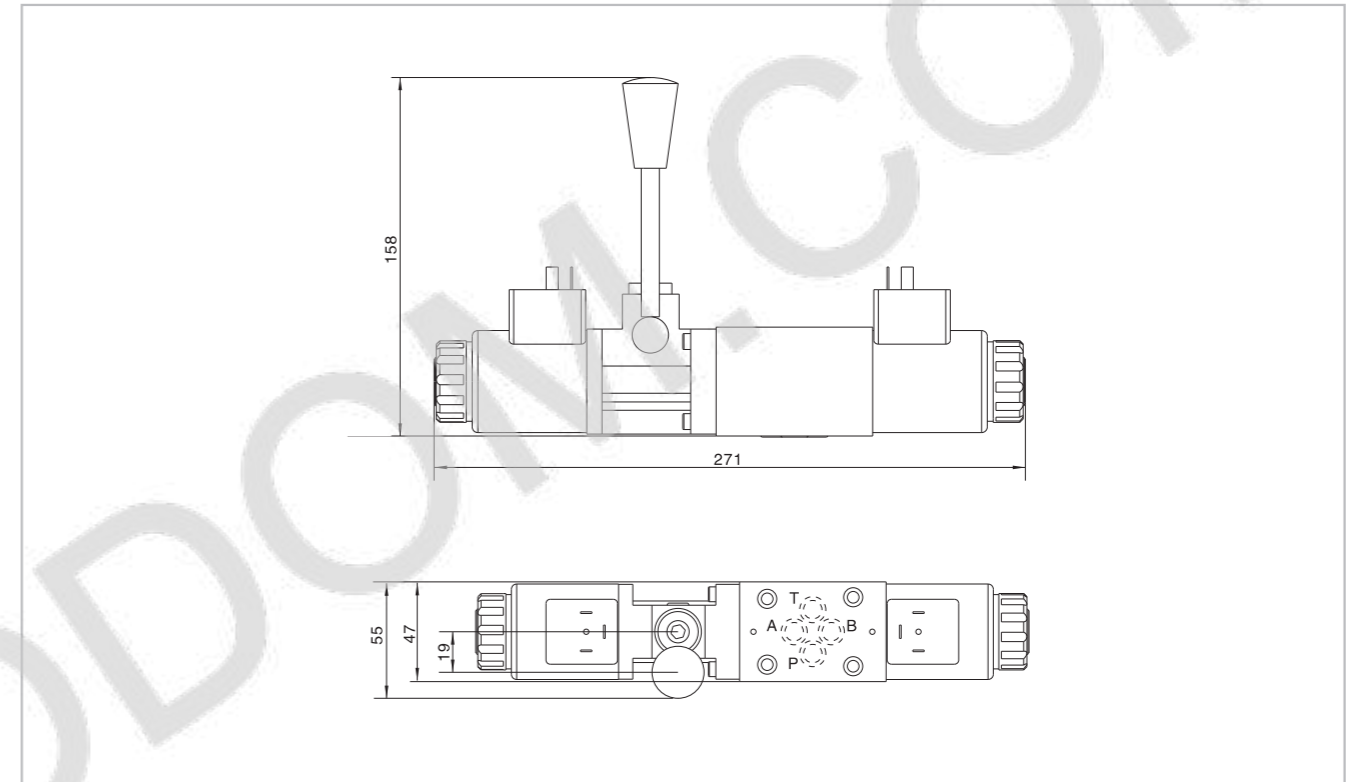

02 Subplate mounting size

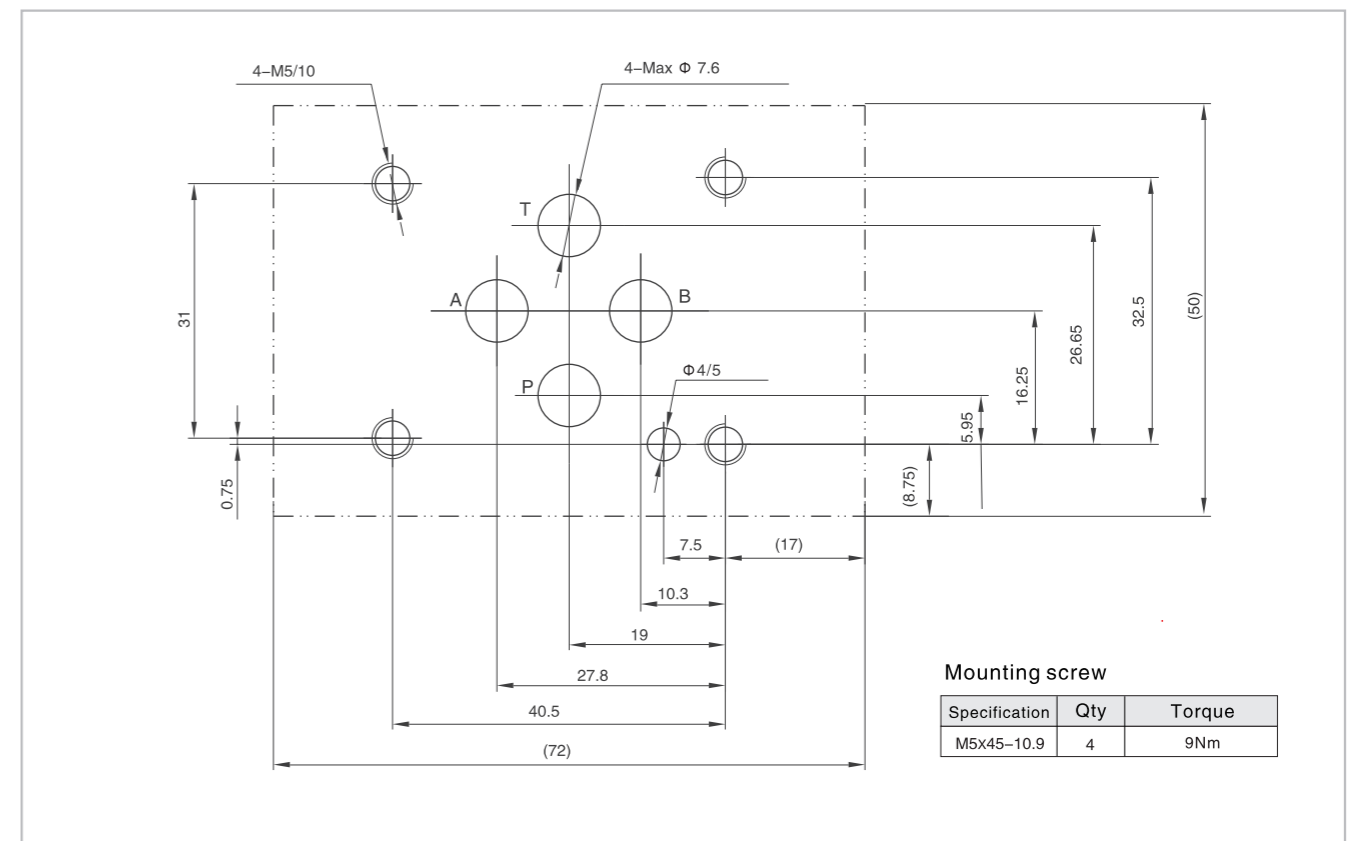

Solenoid Valve With Hand Control

03 Dimension

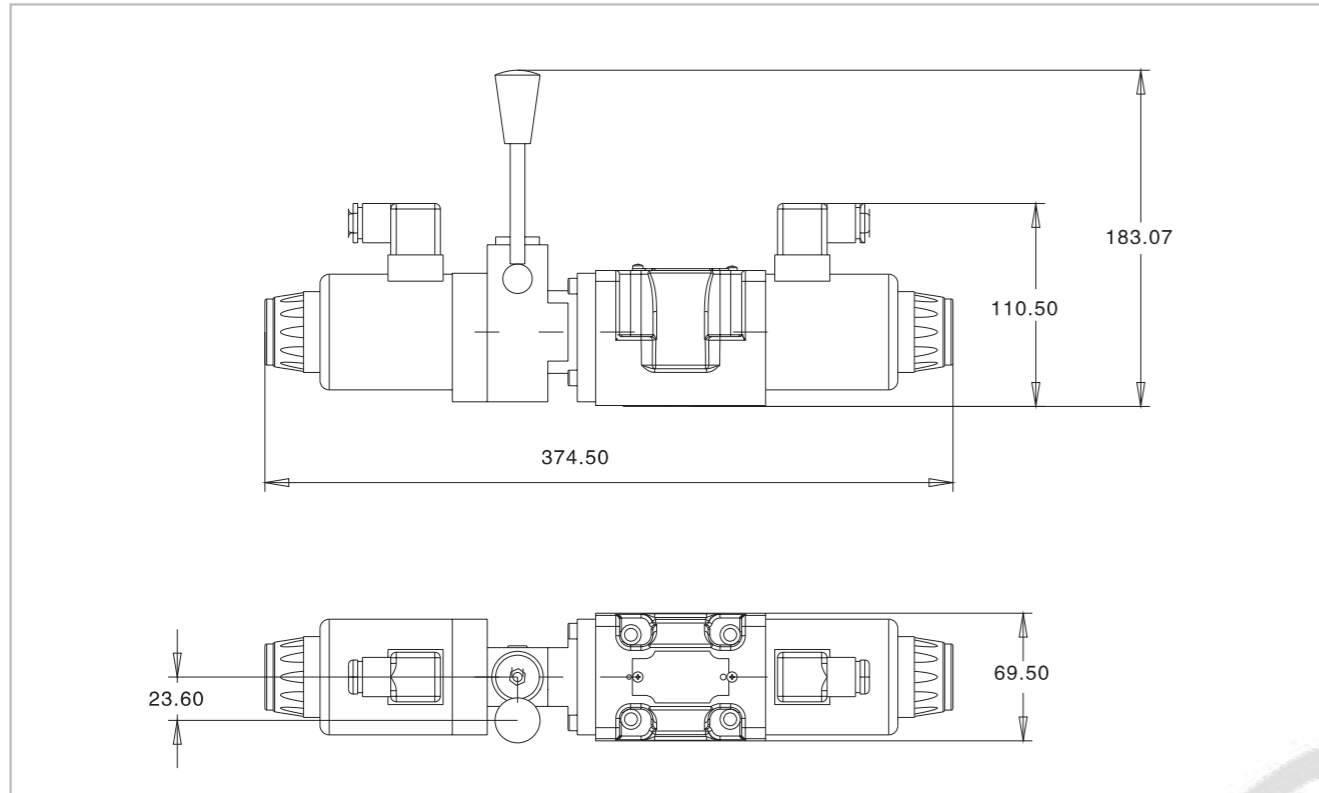

03 Subplate mounting size

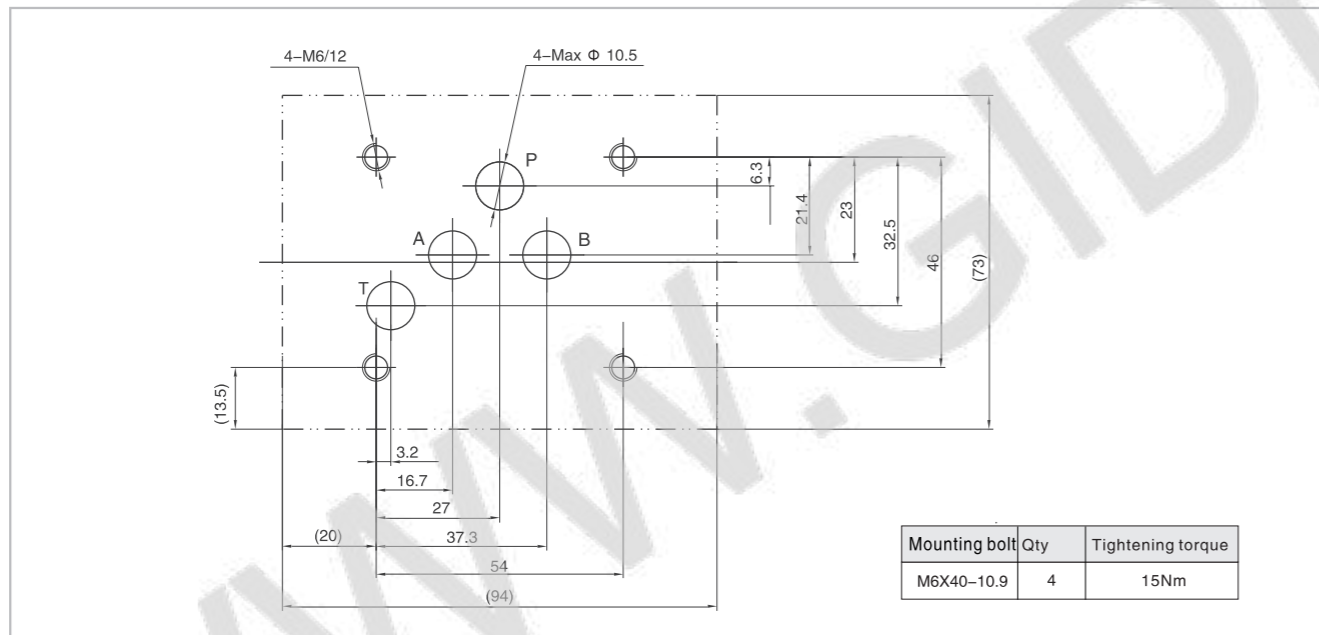

- Notice:
- Please refer to "user's guide" before mounting.
 - When installing the product, considering horizontal position firstly.
 - The medium used in the hydraulic system must be filtered, its accuracy is at least 20 μ m.
 - Screw should be according to the parameters in catalogue.
 - The surface, connecting with the valve, should be Ra0.8 roughness, and 0.01/100mm flatness.

DN04 Solenoid Valve

Technical specification



Specification		04
Max. working pressure (MPa)	Port P, A, B	25
	Port T	10
Max. Flow (L/min)		25
Working fluid	Mineral oil; phosphate-ester	
Fluid temp. (°C)	-20~70	
Viscosity (mm²/s)	2.8~100	
Working voltage (V)	DC 12	DC 24
Insulation grade	IP55	
Cleanliness	The maximum allowable cleanliness of the oil should be according to 9th degree of Standard NAS1638. It is suggested that the minimum filter rating should be β ₁₀ ≥ 75.	

Solenoid valve is controlled by the solenoid to move the spool, so as to control the oil flow direction. It could be used in hydraulic system directly, control the oil on/off; also could be used as pilot valve, to control other valves.

Model description

4 HYWE4 - * - * * * / * * 5X *

4 4Port

DN04 Solenoid valve

Spool type
Details refer to symbol list

Vdtage
D12 DC12V
D24 DC24V

Z5L Square connector with light
Z6 Wire box type

Remarks

Serial number

Seal material
Omit NBR Seals
V FPM Seals

Omit without damping
08 Ø0.8 Damping
10 Ø1.0 Damping
12 Ø1.2 Damping

Omit without hand emergency
N9 with concealed hand emergency

DN04 Solenoid Valve

Code symbol

Spring return

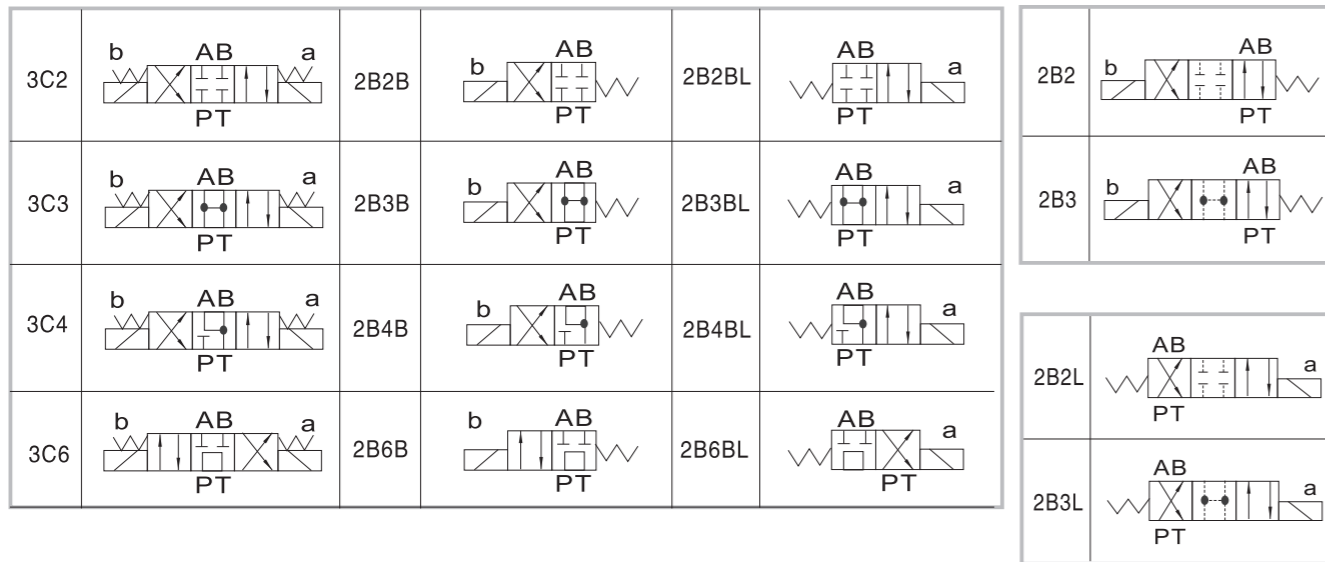

With detent

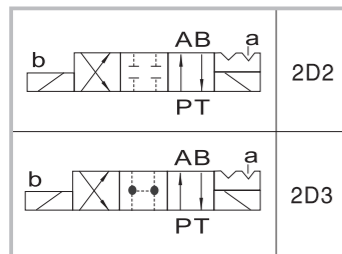

No spring return and no detent mechanical positioning

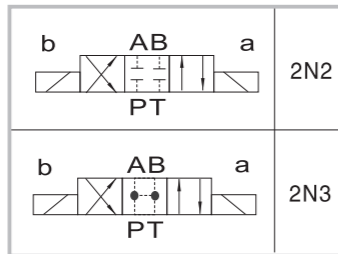

Name of solenoid

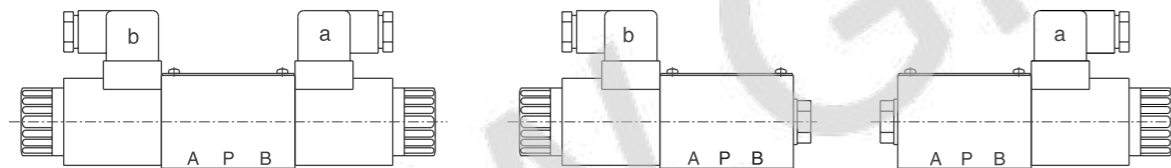

1. a When movement a, P→A B→T
2. b When movement b, P→B A→T
3. Oil flow in the opposite direction with the above-mentioned movement for 3C5、3C6symbol Valve.

DN04 Solenoid Valve

Specification Performance curve (Measured at $v=41\text{mm}^2/\text{s}$ and $t=50^\circ\text{C}$)

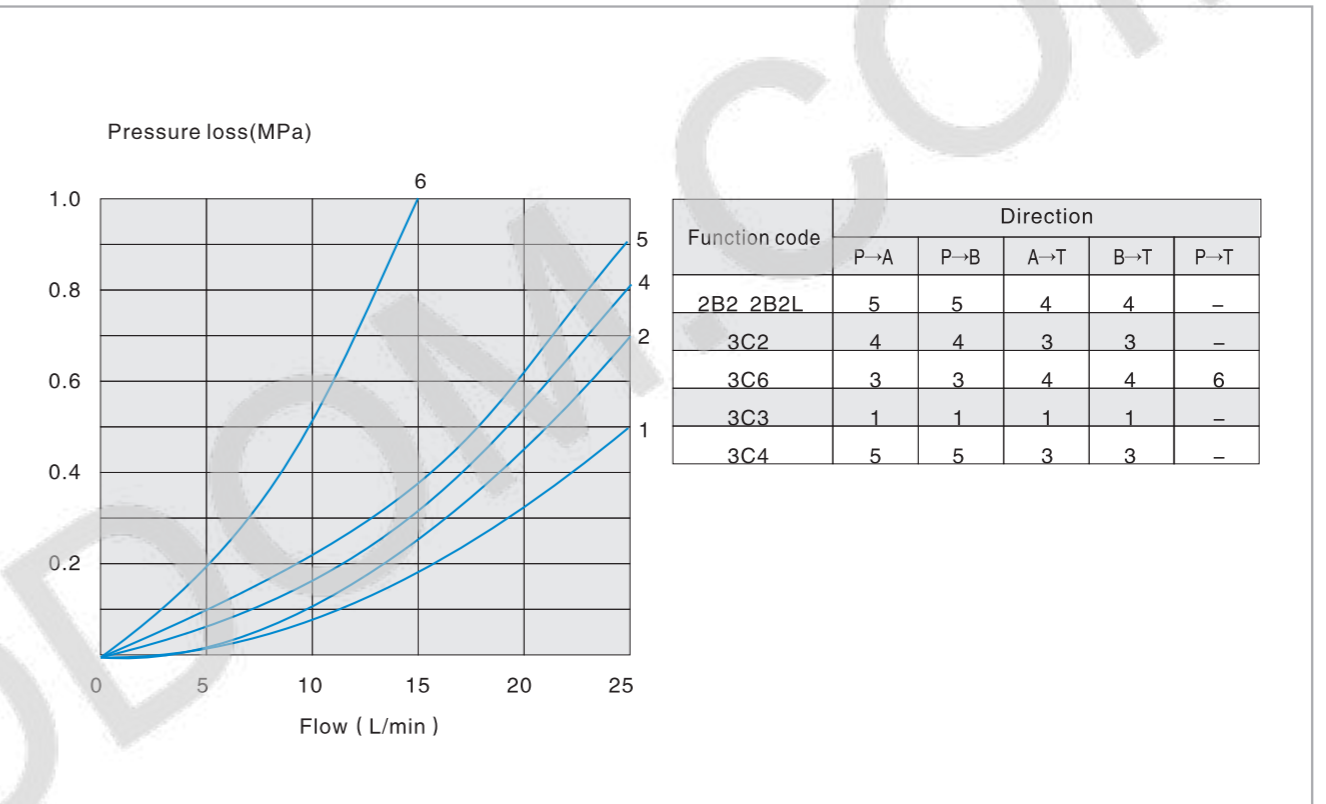

Specification Working limits

With regard to the four-way valve, the normal flow data as shown is get from the regular use of two directions of the flow (e.g.P to A, and simultaneous return flow from B to T). See tables. If only one flow direction is needed, for example: When a four port valve which is closed up port A or port B, used as a three-way valve, the Maximum flow may be very small in the serious condition.
(The working limits for directional valves have determined by using solenoids at their operating temperature, 10% under voltage and with no pre-loading of the tank)

Working pressure(MPa)

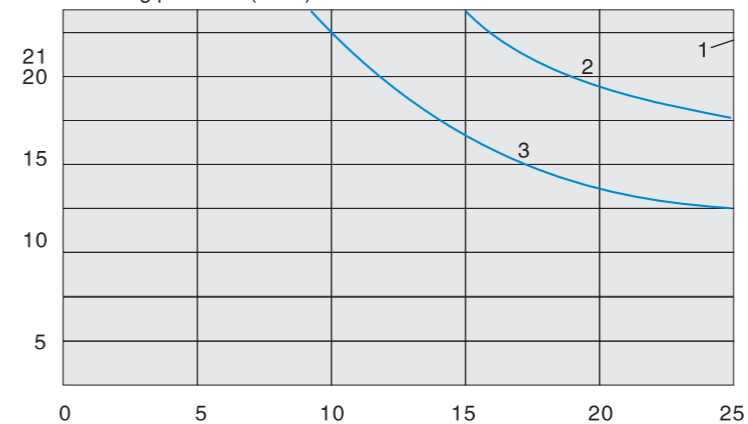

Cunoe	Spool
1	2B2 2D2 2N2 2B2L
2	3C2 3C4
3	3C6

DN04 Solenoid Valve

External dimensions

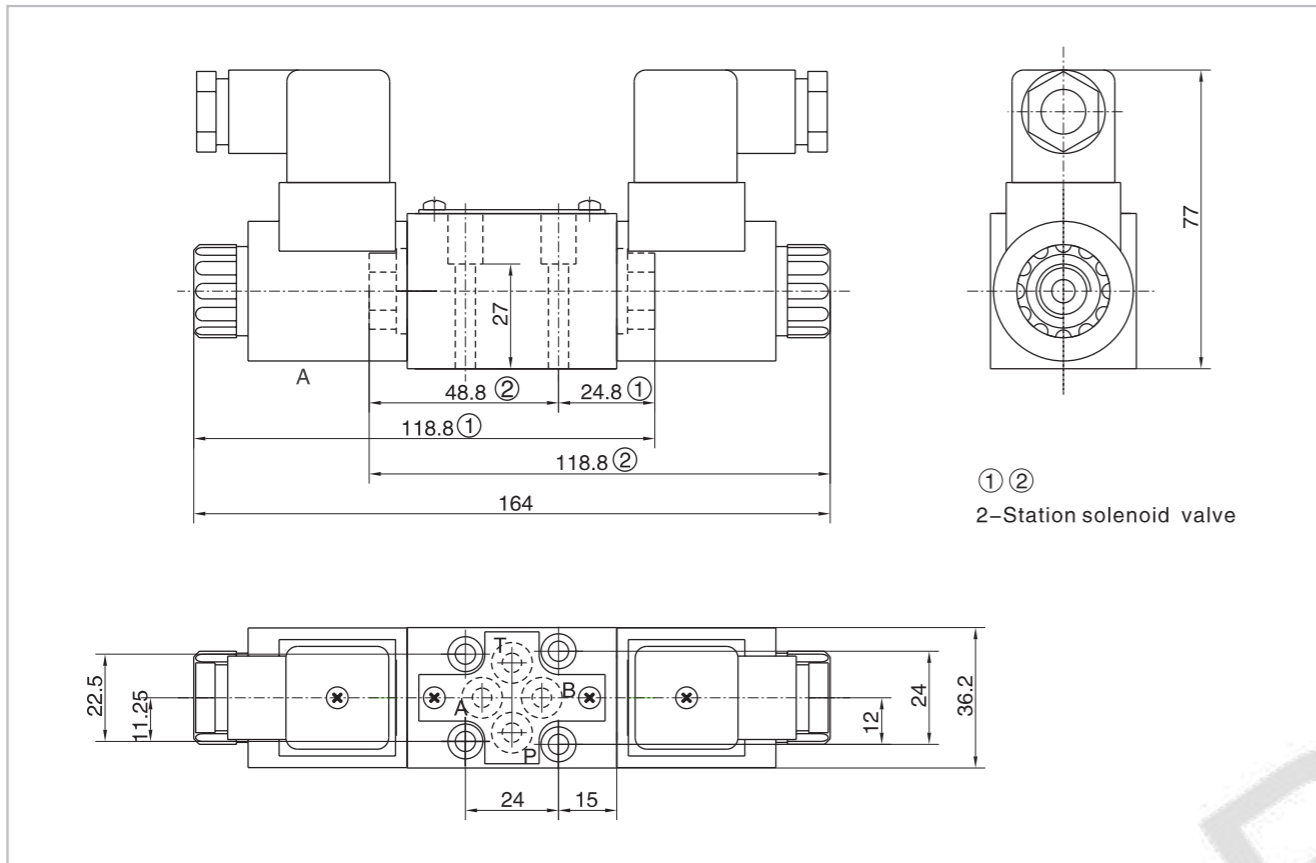

Size of subplate

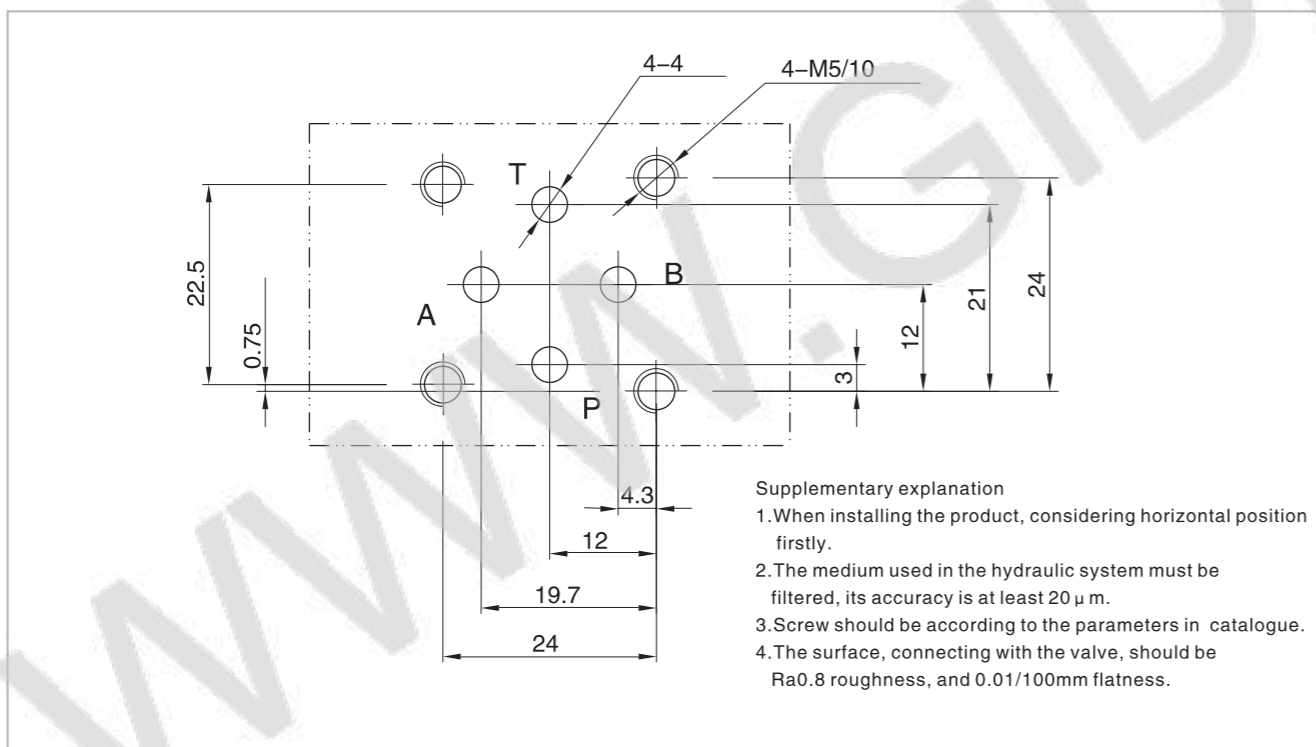

HOYEA

2-way Cartridge Valve Series



Brief

2-way cartridge valves are elements that have been designed for a compact block design. In most cases, the cover is simultaneously the connection from the control side of the power section to the pilot control valves.

By control with respective pilot control valves, the power section can be applied for pressure, directional and throttle functions or a combination of these functions.

Particularly efficient solutions are realized by adjustment of the size to various flows of the individual ways of an actuator.

The power section with connections A and B is installed into the control block in a receiving hole standardized according to ISO 7368 and closed with a cover.

The application of power sections of elements for multiple functions is very cost-effective a hydraulically controlled directional seat valve or a shuttle valve according to the required overall function.

2-way cartridge valves generally consist of control cover and installation kit.

The control cover contains the control bores and optionally a stroke limitation function,

Additionally, electrically operated directional spool or seat valves can be installed at a control cover.

The installation kit consists of a bushing, ring (only up to NG32), valve poppet, optionally with damping nose or without damping nose as well as closing spring.

The function of 2-way cartridge valves is pressure-dependent. This way, three crucial pressurized areas A_A, A_B, A_X are realized for the function.

The area at the valve seat A_A is considered as 100%. Depending on the version, the annulus area A_B realized by grading is 7% or 50% of area A_A.

The area ratio A_A : A_B is respectively either 14.3 : 1 or 2 : 1. The area A_X is identical to the sum of areas A_A + A_B.

Due to the different area ratios A_A : A_B and the resulting different annulus areas (A_B),

The area A_X is one time 107% and another time 150% of the area A_A at the seat, which is observed as 100%

2-way Cartridge Valve (Direction Function)

Technical data

技术参数 technical specification



Size	16	25	32	40	50	63
Max working pressure (Mpa)	31.5					
Max flow rate (L/min)	160	460	800	1200	1800	2700
Working fluid	Mineral hydraulic oil; phosphate ester hydraulic oil					
Fluid temp (°C)	-20~70					
Fluid viscosity (mm ² /s)	-2.8~500					
Cleanliness	NAS1638 Class 9, recommended filtration precision Min β ≥75.					

HYLC is a high-flow rate and high-pressure logic valve mainly to control the oil on/off, shall work together with the coverplate.

Model description

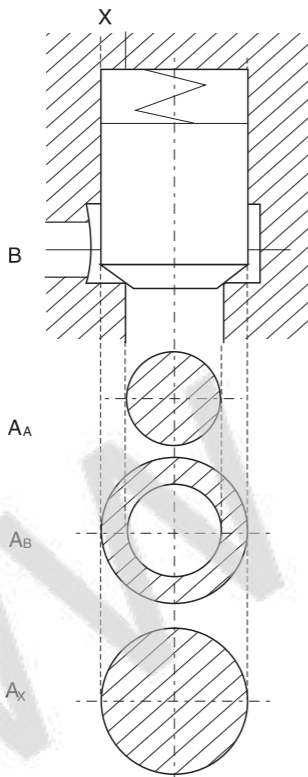

HYLC - * - * - * - * - * / 5X *

2-way cartridge valve (direction function)	Remark
Specification 16 DN16 25 DN25 32 DN32 40 DN40 50 DN50 63 DN63	Serial number 5 0 51
50 series A area ratio 2:1 (annular area=50%) B area ratio 14.3:1 (annular area=7%) 90series area ratio 3:1 (annular area=33%)	Seal material omit NBR V FPM
	E Valve poppet without damping nose D Valve poppet with damping nose
	00 Cracking pressure 0 bar (without spring) 05 Cracking pressure approx. 0.05Mpa 10 Cracking pressure approx. 0.1Mpa 20 Cracking pressure approx. 0.2Mpa 40 Cracking pressure approx. 0.4Mpa

Control Cover Type Hylfa

Model description

LFA...D.../F

Control cover with remote control port
Size:16-63

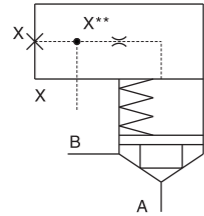

LFA...H2.../F

Control cover with stroke limitation and remote control port
Size:16-63

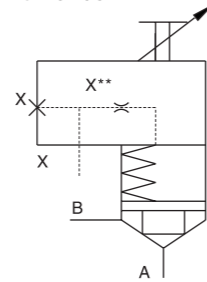

LFA...G.../...

Control cover with integrated shuttle valve
Size:16-63

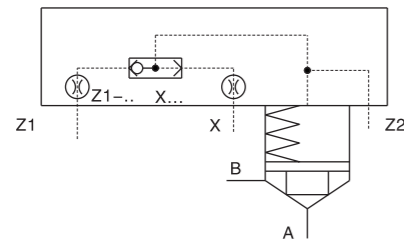

LFA...R.../...

Control cover with integrated pilot operated pilot control valve (directional seat valve)
Size:16-63

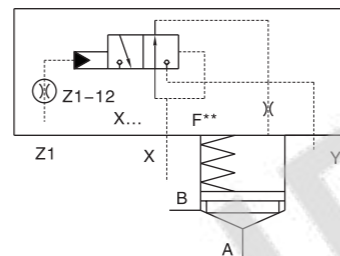

LFA...WEA.../...

Control cover for set-up of a directional valve
Size:16-63

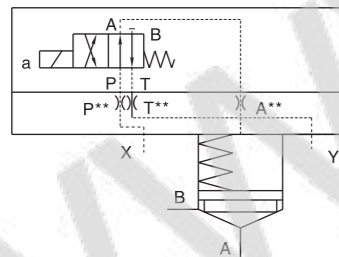

LFA...WEA8-60/...

Control cover for set-up of a directional valve; additional control port
Size:16-63

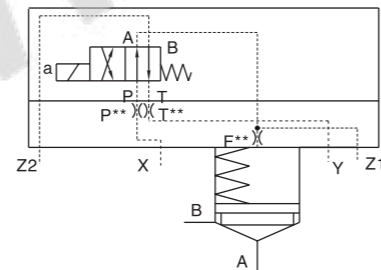

Control Cover Type Hylfa

Model description

LFA...WEA9-60/...

Control cover for set-up of a directional spool valve as check valve circuit
Size:16-63

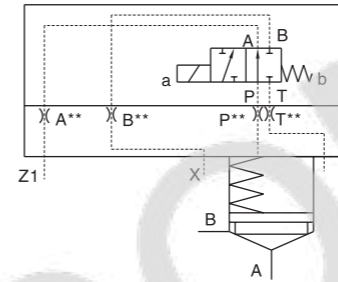

LFA...GWA.../...

Control cover for set-up of a directional spool valve or seat valve, with integrated shuttle valve
Size:16-63

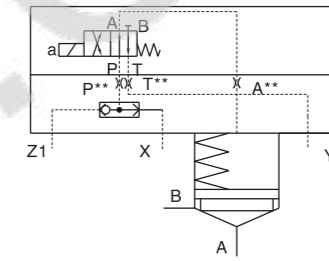

LFA...KWA.../...

Control cover with shuttle valve and for set-up of a directional valve (check valve circuit)
Size:16-63

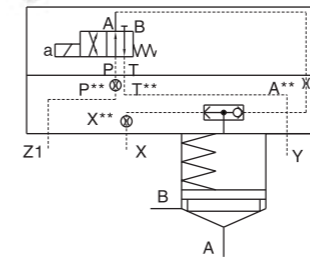

LFA...E60/...DQ.G24F

Control cover with electric close position monitoring, incl. installation kit
Size:16-63

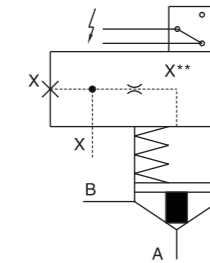

LFA...EH2-60/...DQ.G24F

Control cover with electric close position and stroke limitation monitoring, incl. installation kit
Size:16-63

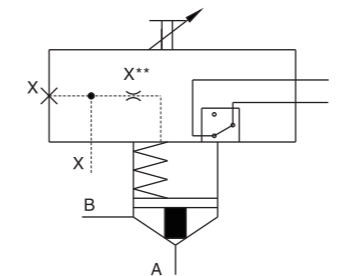

LFA...EWA60/...DQOG24

Control cover with electric monitoring of the close position, for mounting a directional spool valve
Size:16-63

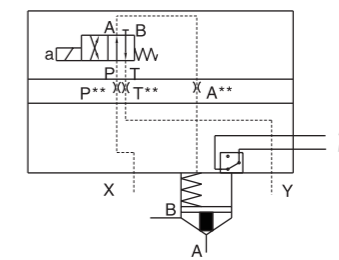

2-way Cartridge Valve (Pressure Function)

Technical data



Size	16	25	32	40	50	63
Max working pressure (MPa)	31.5					
Max flow rate (L/min)	250	400	600	1000	2000	2500
Working fluid	Mineral hydraulic oil; phosphate ester hydraulic oil					
Fluid temp (°C)	-20~70					
Fluid viscosity (mm ² /s)	-2.8~500					
Cleanliness	NAS1638 Class 9, recommended filtration precision Min β ≥75.					

HYLC is a high-flow high-pressure logic valve, mainly to control the hydraulic oil on/off shall work together the coverplate

Model description

HYLC - * - DB - * - * - * / 5X *

pressure relief cartridge valve

Remark

Serial number

Seal material omit NBR V FPM

E Poppet valve
D Spool poppet valv
A Poppet valve with orifice
B Spool poppet valve with orifice

Specification
16 DN16
25 DN25
32 DN32
40 DN40
50 DN50
63 DN63

00 Opening pressure approx. 0 Mpa (without spring)
20 Opening pressure approx. 0.2 Mpa
40 Opening pressure approx. 0.4 Mpa

2-way Cartridge Valve (Pressure Function)

Dimension

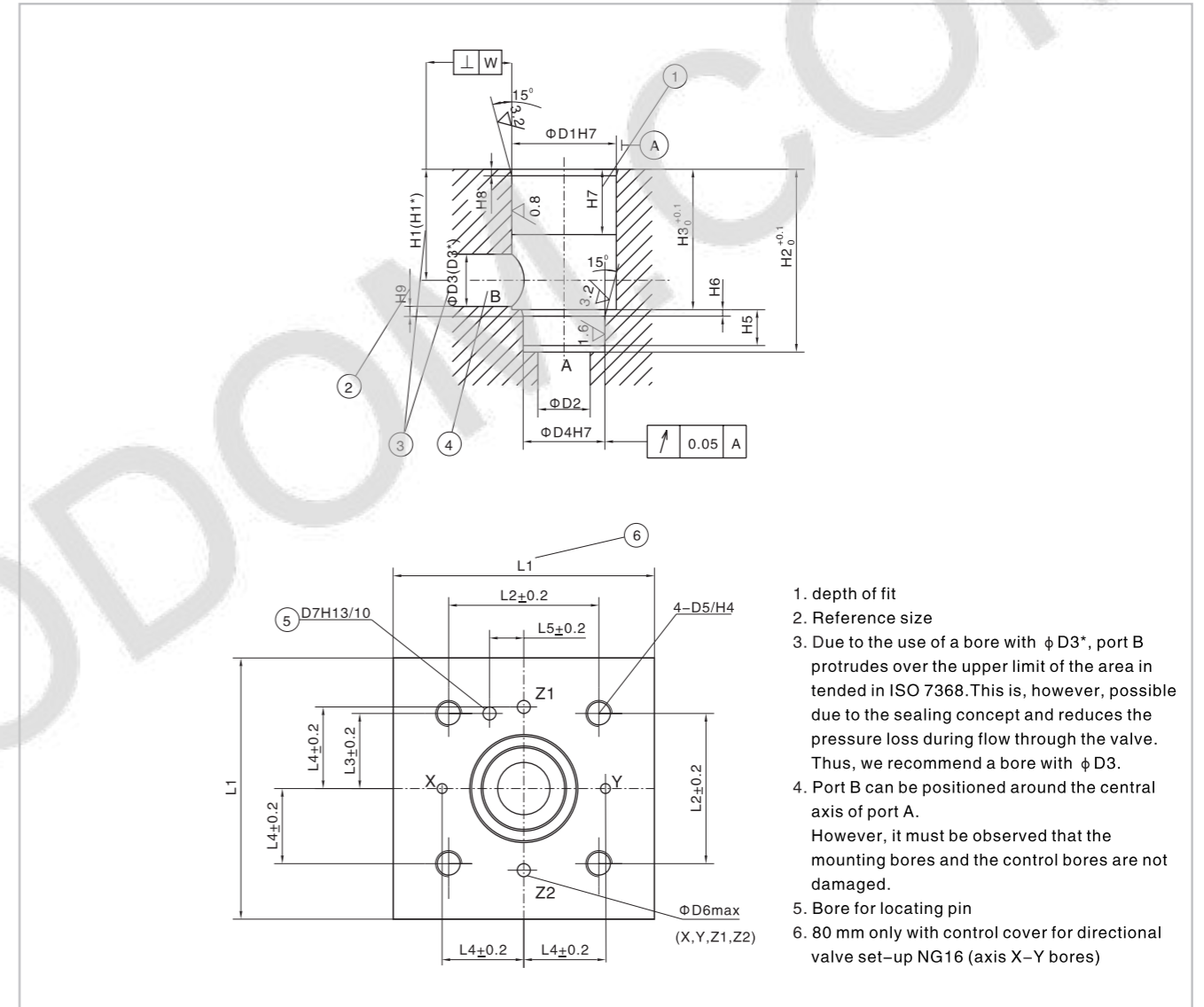

Specification	ΦD1H7	ΦD2H7	ΦD3H7	(ΦD3*)	ΦD4	ΦD5	ΦD6H7	ΦD7	H1	(H1*)	H2	H3
16	32	16	16	25	25	M8	4	4	34	29.5	56	43
25	45	25	25	32	34	M12	6	6	44	40.5	72	58
32	60	32	32	40	45	M16	8	6	52	48	85	70
40	75	40	40	50	55	M20	10	6	64	59	105	87
50	90	50	50	63	68	M20	10	8	72	65.5	122	100
63	120	63	63	80	90	M30	12	8	95	86.5	155	130

Size	H4	H5	H6	H7	H8	H9	L1	L2	L3	L4	L5	W
16	20	11	2	20	2	0.5	65/80	46	23	25	10.5	0.0
25	25	12	2.5	30	2.5	1	85	58	29	33	16	0.05
32	35	13	2.5	30	2.5	1.5	102	70	35	41	17	0.1
40	45	15	3	30	3	2.5	125	85	42.5	50	23	0.1
50	45	17	3	35	4	2.5	140	100	50	58	30	0.1
63	65	20	4	40	4	3	180	125	62.5	75	38	0.2

Coverplate(Pressure Function)

Technical data



Size	16	25	32	40	50	63
Max working pressure (MPa)	31.5					
Working fluid	Mineral hydraulic oil; phosphate ester hydraulic oil					
Fluid temp (°C)	-20~70					
Fluid viscosity (mm ² /s)	-2.8~500					
Cleanliness	NAS1638 Class 9, recommended filtration precision Min β ≥75.					

HYLFA is to control the logic valve on/off, different coverplate can realize different fluid pressure.

Ordering code

HYLFA - * - * - * / 5X *

Coverplate(pressure function)

Specification
 16 DN16
 25 DN25
 32 DN32
 40 DN40
 50 DN50
 63 DN63

Model
 Refer to code details

Remark

Serial number

Seal material
 omit NBR
 V FPM

Coverplate(Pressure Function)

Ordering code

LFA...DB.-/..16...63
 Control cover with manual pressure adjustment

LFA...DBW.-/..16...63
 Control cover with manual pressure adjustment, for electrical unloading
 For mounting a directional spool or directional poppet valve

LFA...DBS.-/..16...63
 Control cover with manual pressure adjustment, for electrical unloading
 For mounting a directional poppet valve

LFA...DBWD.-/..16...63
 Control cover with manual pressure adjustment, for isolation functions

Coverplate (Pressure Function)



Function code

LFA...DBU 2A.-/..16...63

Control cover with 2 manual pressure adjusters, electrically selectable

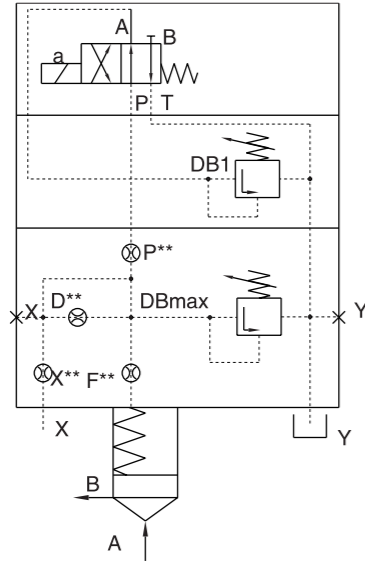

LFA...DBU 3D.-/..16...63

Control cover with 3 manual manual pressure adjusters, electrically selectable

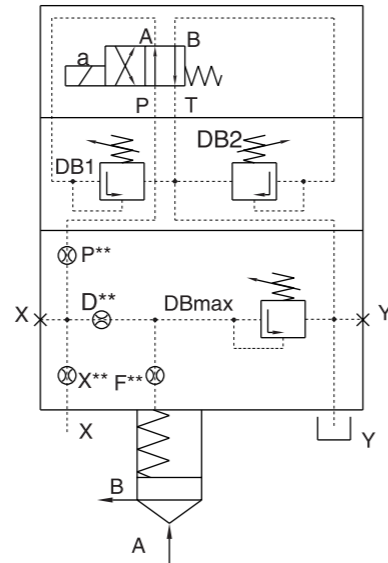

LFA...DBU(TR).-/..16...63

Control cover for electrical-proportional pressure adjustment

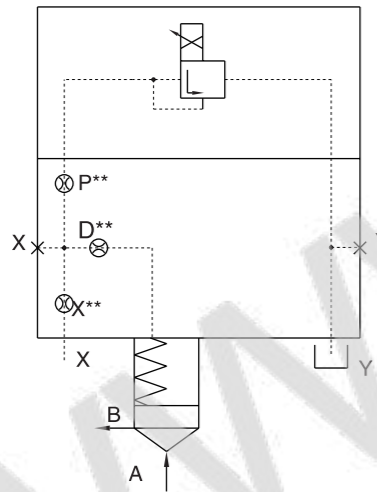

LFA...DBEM(TR).-/..16...63

Control cover for electrical-proportional pressure adjustment, with maximum pressure limitation

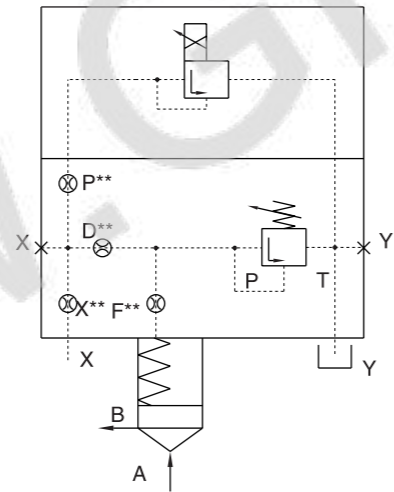

Modular Valves Series



DN04 Modular Pilot Check Valve

Technical specification

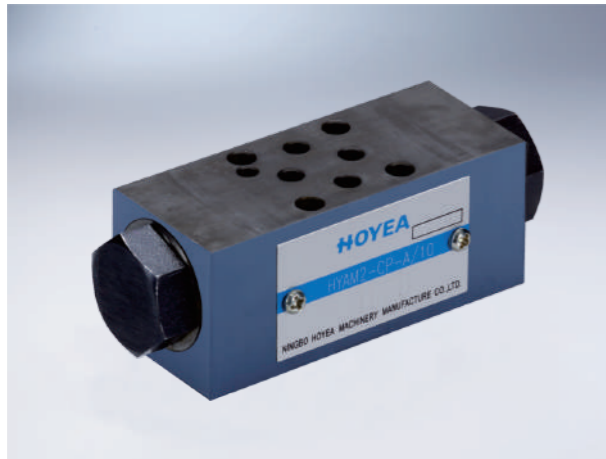

DN	4
Max. working pressure (MPa)	31.5
Max. Flow (L/min)	30
Working fluid	Mineral oil; phosphate-ester
Fluid temp. (°C)	-20~70
Viscosity (mm²/s)	2.8~500
Opening pressure (MPa)	a 0.2 b 0.4
Cleanliness	The maximum allowable cleanliness of the oil should be according to 9th degree of Standard NAS1638. It is suggested that the minimum filter rating should be $\beta_{10} \geq 75$.

Model description

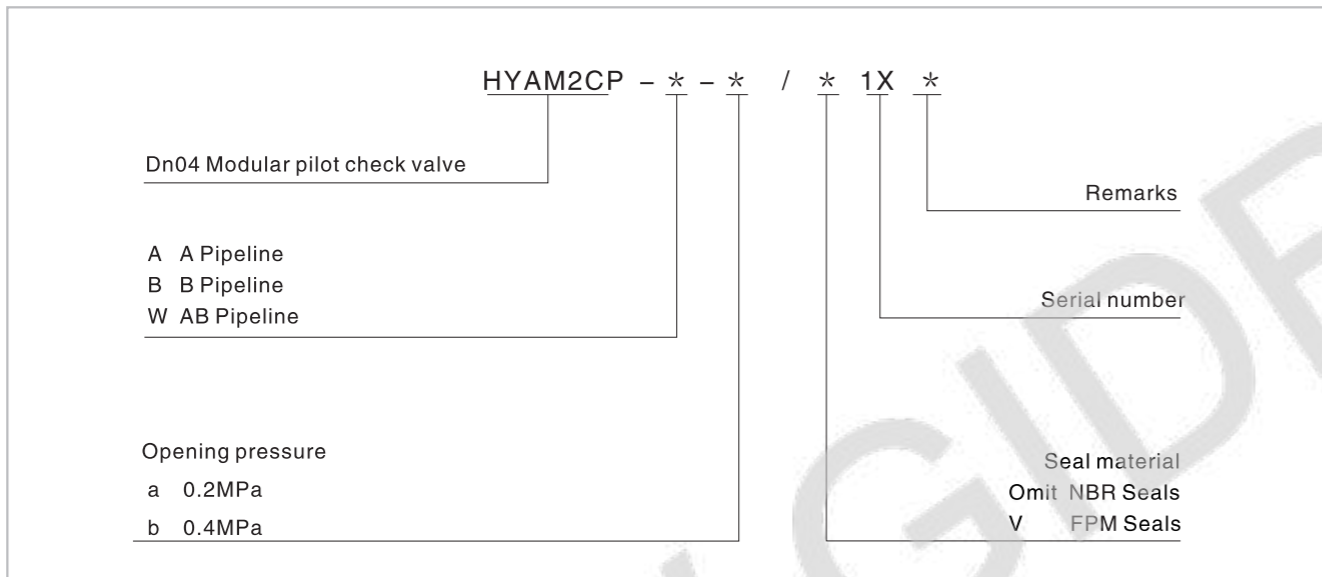

Code symbol

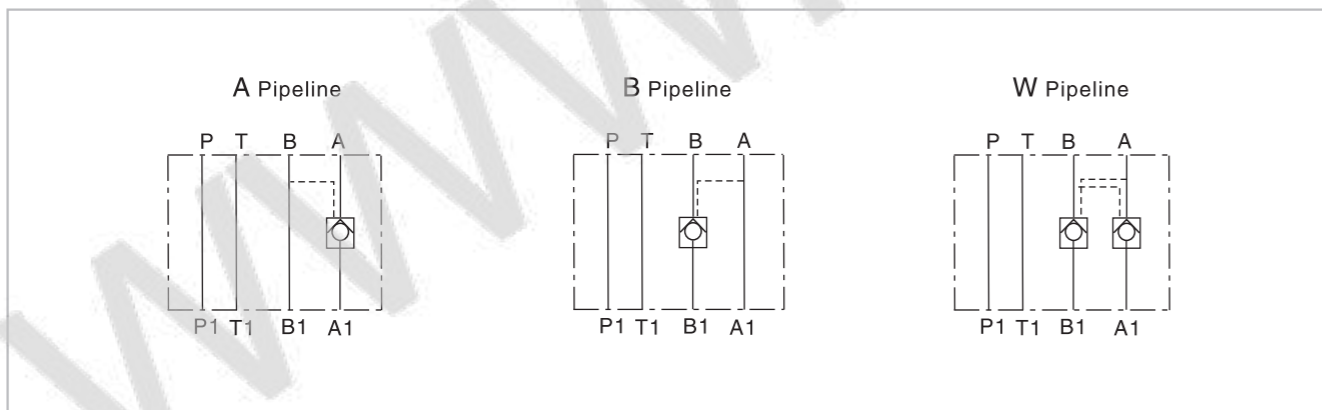

DN04 Modular Pilot Check Valve

External dimensions

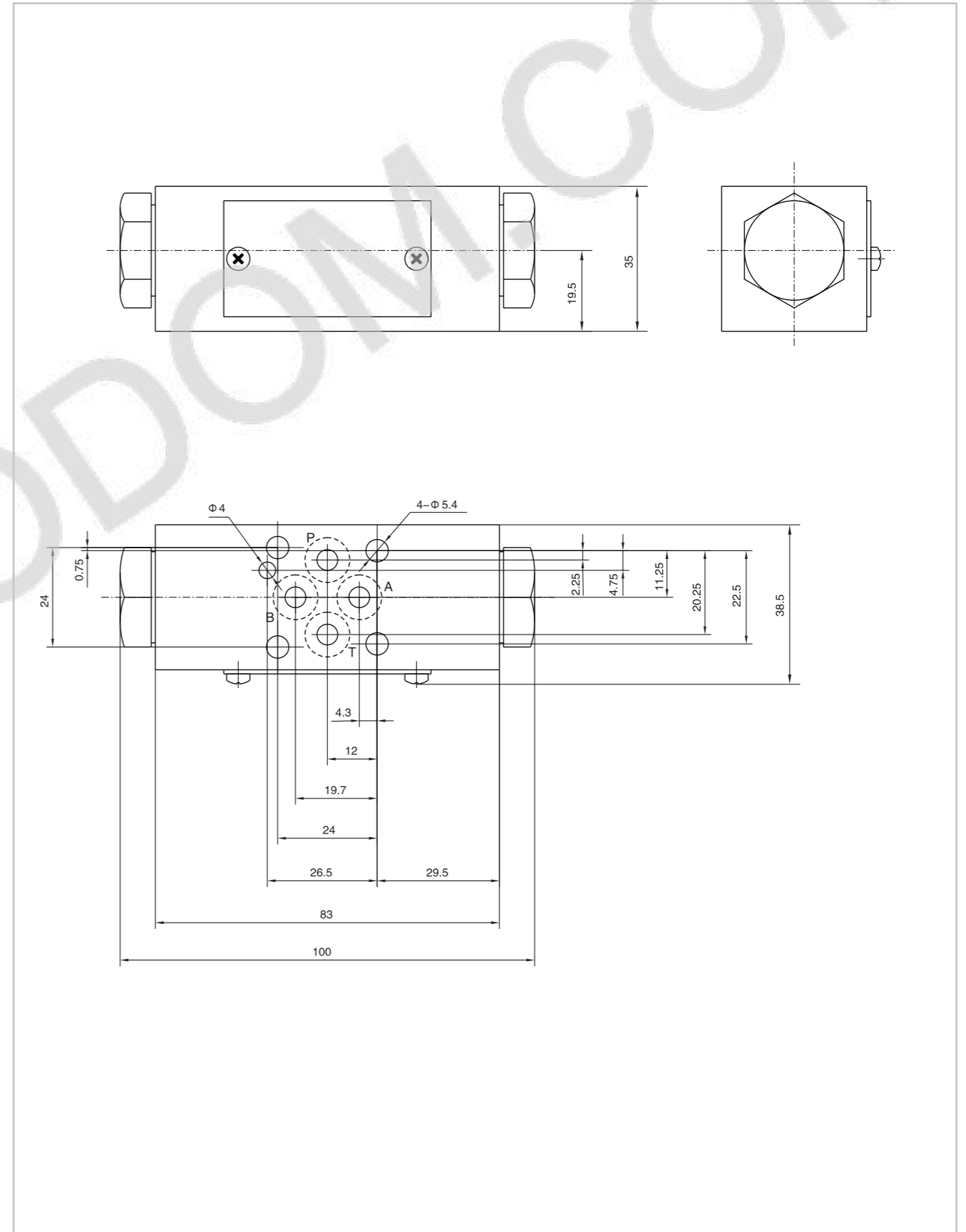

Modular Relief Valve

Technical specification



Specification	02	03
Max working pressure (MPa)	31.5	
Max F (L/min)	60	100
Working fluid	Mineral hydraulic oil; phosphate ester hydraulic oil	
Fluid temp.(°C)	-20~70	
Viscosity (Mm ² /s)	10~800	
Working voltage (MPa)	5, 10, 20, 31.5	
Cleanliness	NAS1638 Class 9, recommended filtration precision Min β ₁₀ ≥ 75.	

Ordering code

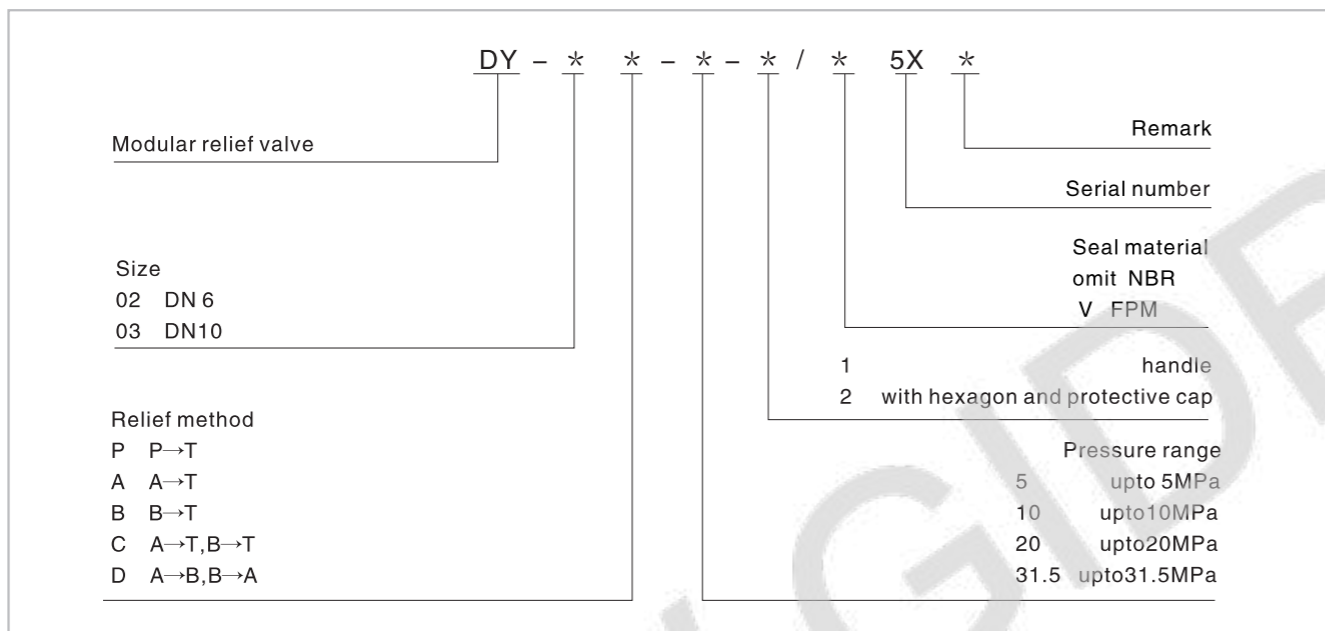

Hydraulic symbol

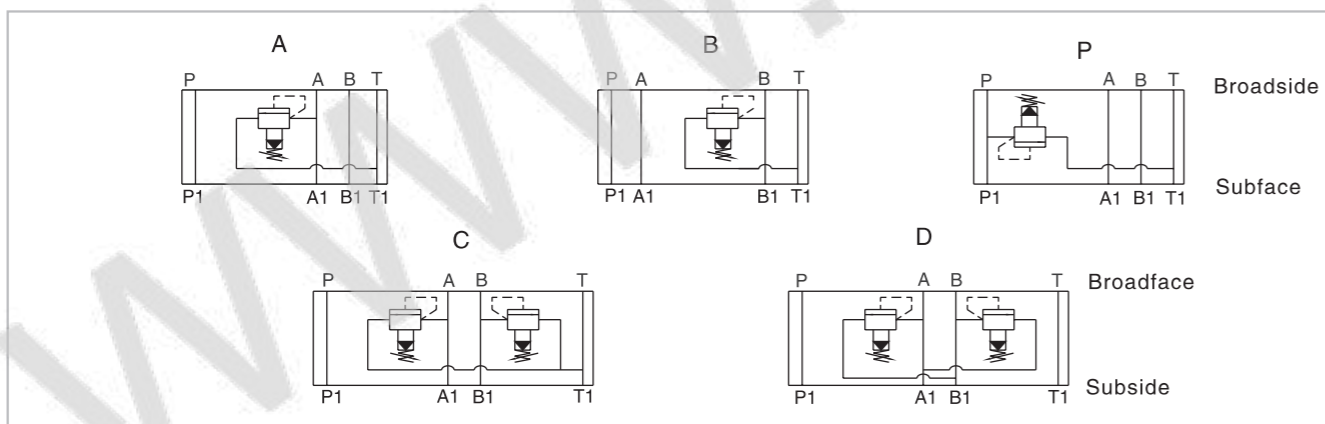

Modular Relief Valve

External dimensions

DY-02A

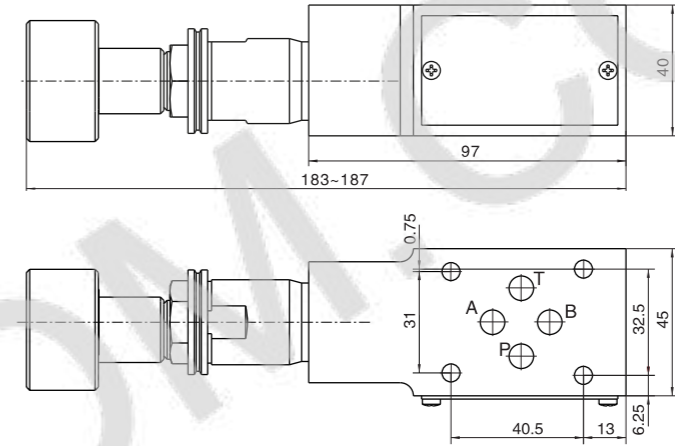

DY-02B,P

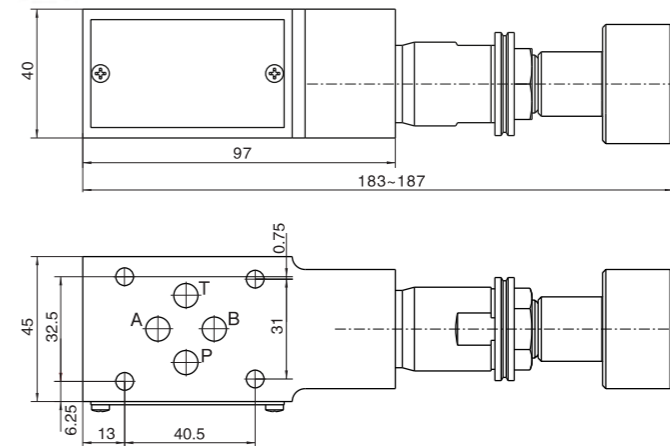

DY-02C, D

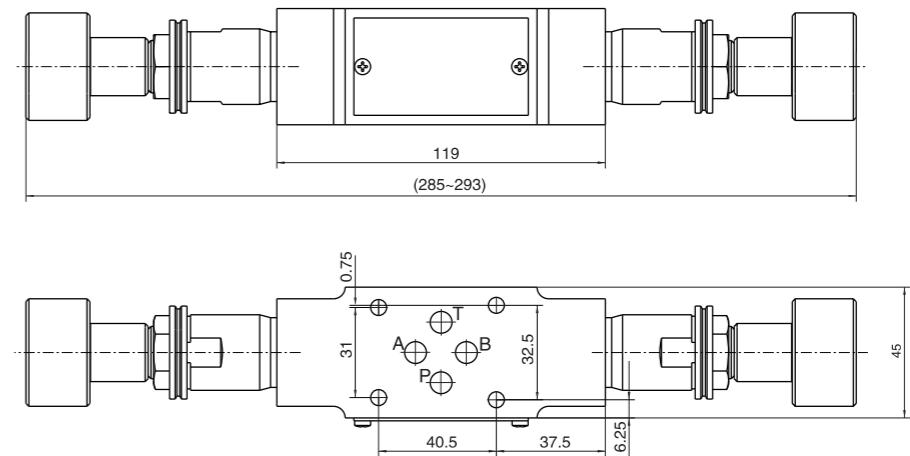

Modular Relief Valve

External dimensions

DY-03A,P

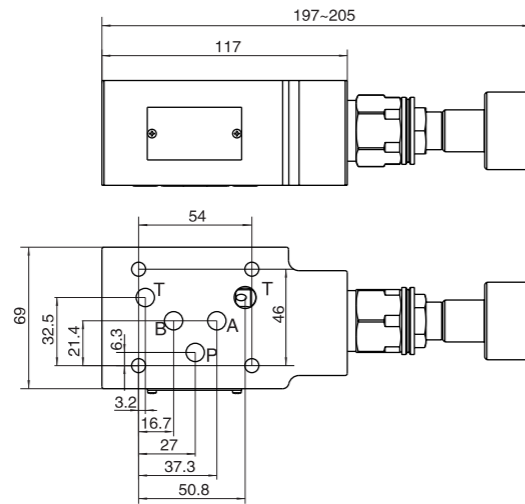

DY-03B

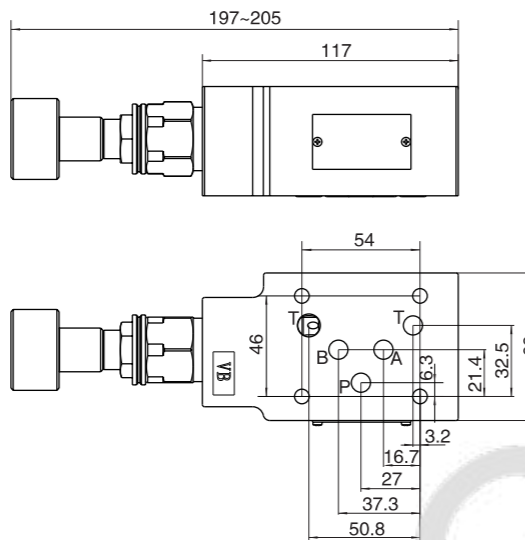

DY-03C , D

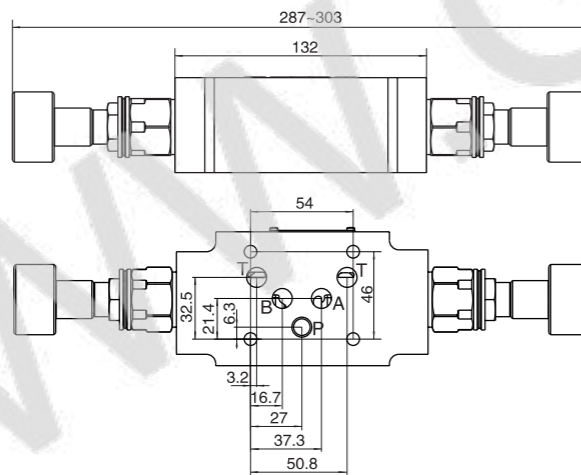

Note: The surface, connecting with the valve, should be Ra0.8 roughness, and 0.01/100mm flatness.

Modular Reducing Valve

Technical specification



Specification	6	10
Max working pressure (MPa)	Working pressure	31.5
	Secondary pressure	To21
	Port T	To15
Max Flow (L/min)	50	
Mounting location	Any	
Working fluid	Mineral hydraulic oil; phosphate ester hydraulic oil	
Fluid temp (°C)	-20~70	
Viscosity (mm ² /s)	10~800	
Cleanliness	NAS1638 Class 9, recommended filtration precision Min β ₁₀ ≥ 75.	

Ordering code

DYJ - * * - * * - * / * 5X *		Remark
Modular reducing valve		Serial number
Specification 02 DN6 03 DN10		Seal material omit NBR V FPM
P P pipeline reducing A A pipeline reducing B B pipeline reducing (only for DN10)		1 plastic handle 2 steel handle
2.5 upto 2.5MPa 7.5 upto 7.5MPa 15 upto 15MPa 21 upto 21MPa		Omit none D check valve

Hydraulic symbol

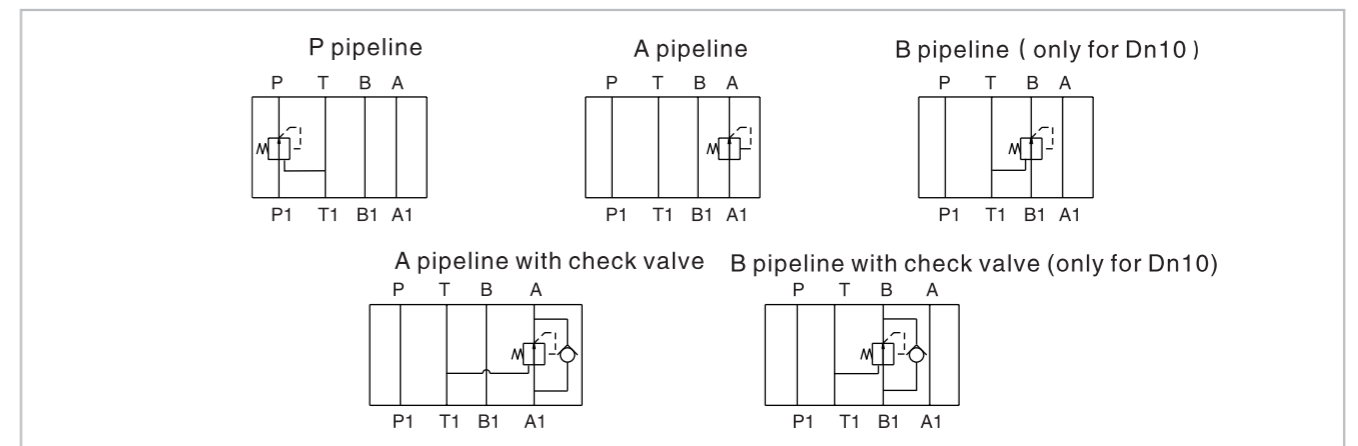

Modular Reducing Valve

Dimension

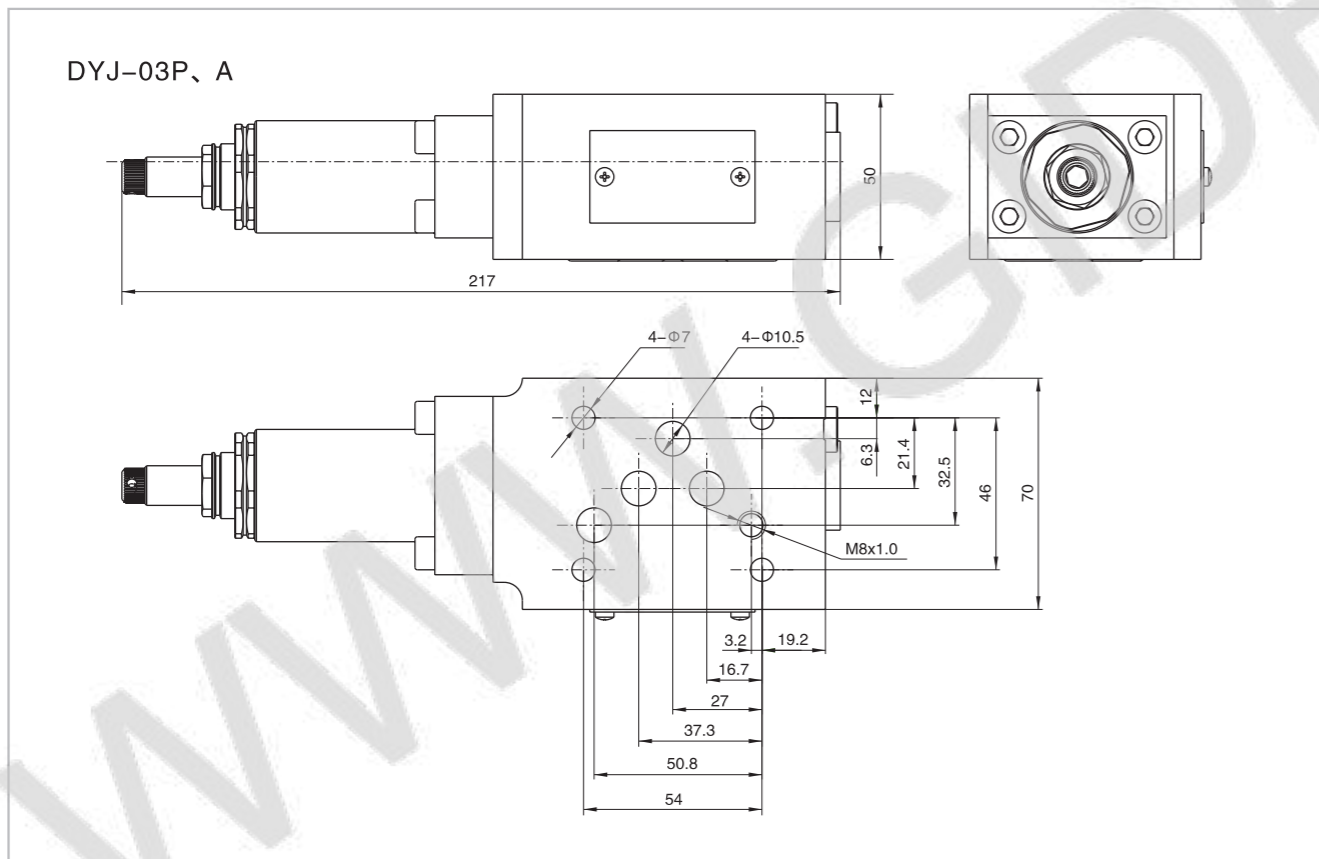
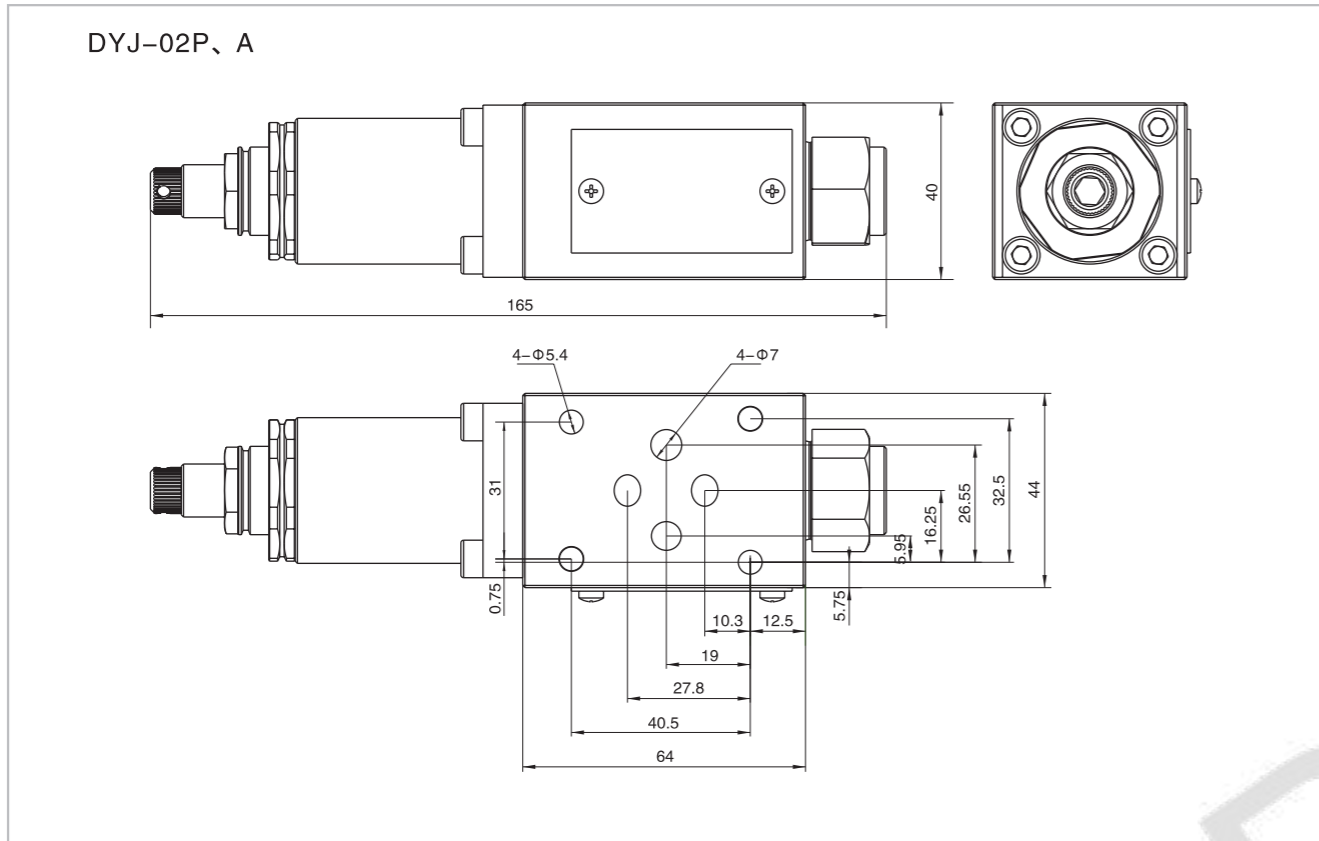

Modular Reducing Valve

Dimension

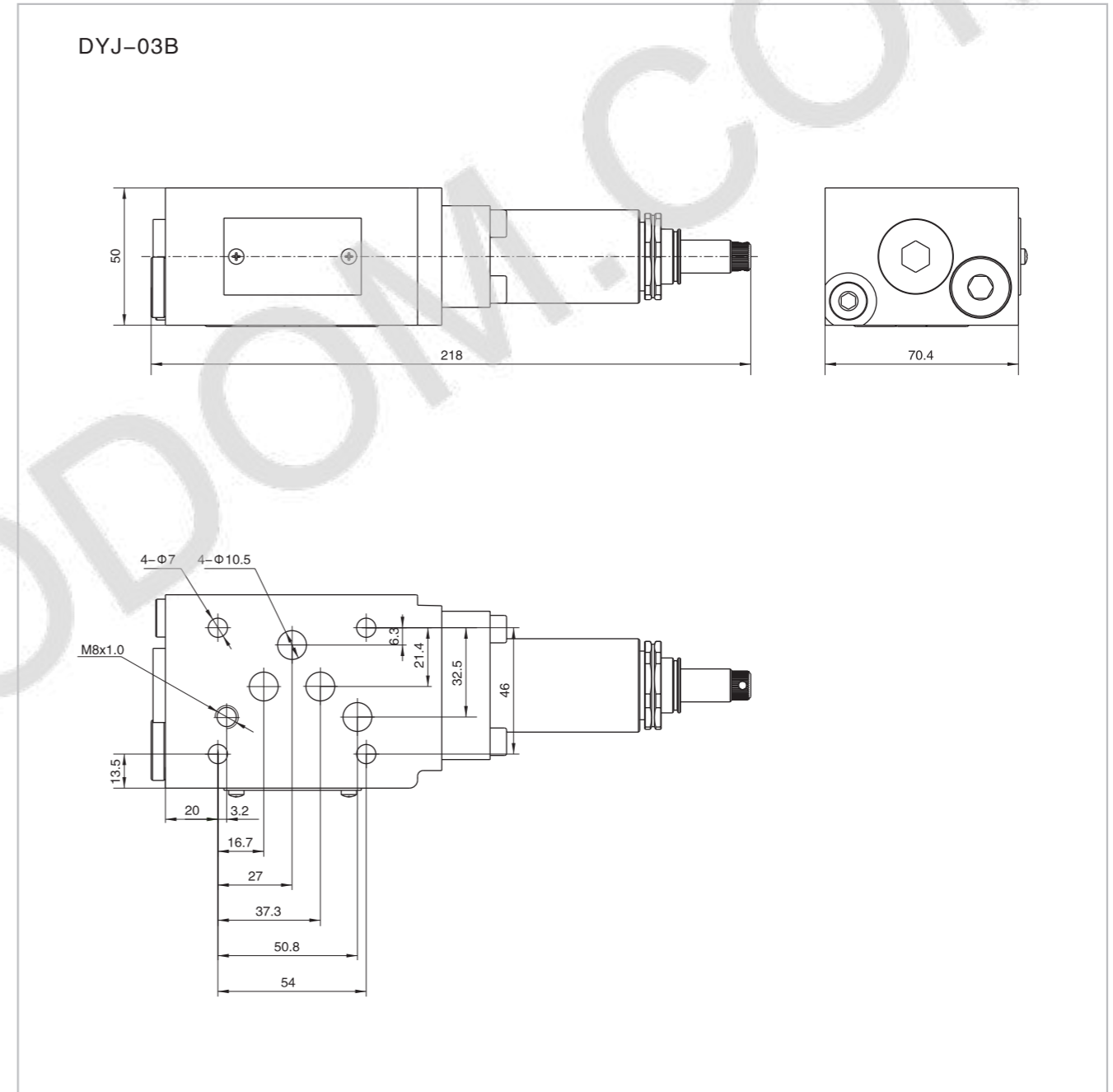

Note: The surface, connecting with the valve, should be Ra0.8 roughness, and 0.01/100mm flatness.

Modular Flow Control Valve

Technical data



Specification	6	10	16	25
Max working pressure (MPa)	31.5			
Max Flow (L/min)	80	160	250	360
Mounting location	Any			
Working fluid	Mineral hydraulic oil; phosphate ester hydraulic oil			
Fluid temp (°C)	-20~70			
Viscosity (Mm ² /s)	10~800			
Cleanliness	NAS1638 Class 9, recommended filtration precision Min $\beta_{10} \geq 75$.			

Please consult us if your application is over above-mentioned data.
DLA is to adjust the flow rate of the two working ports or the pilot flow.

Ordering code

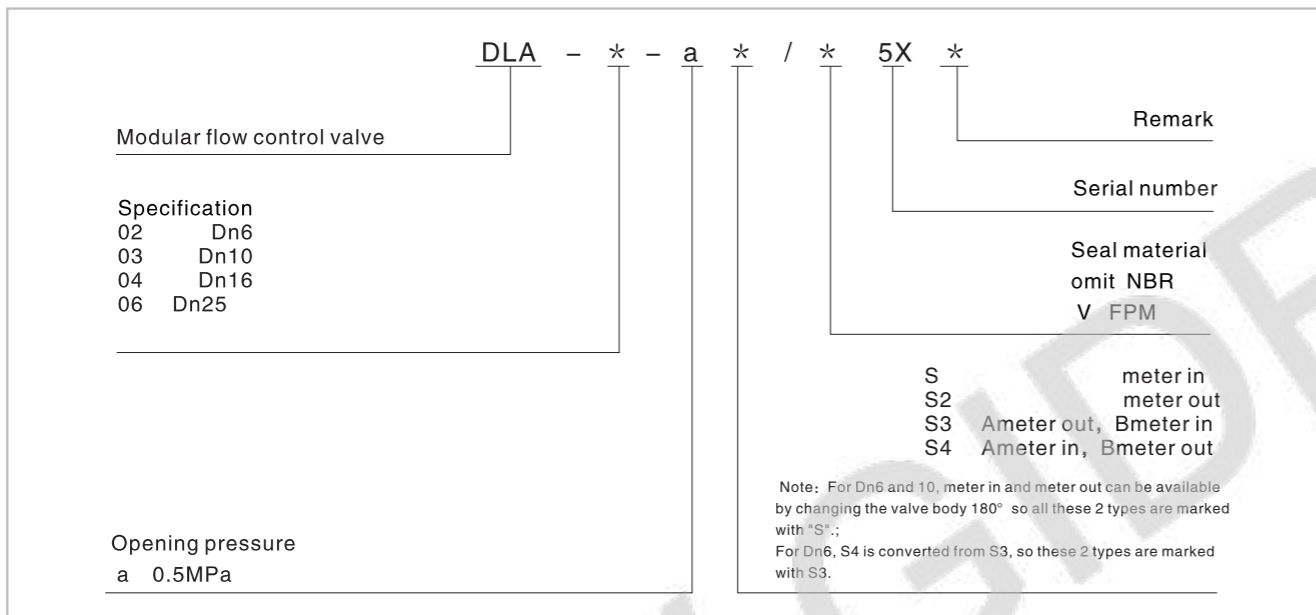

Hydraulic symbol



Modular Flow Control Valve

Dimension

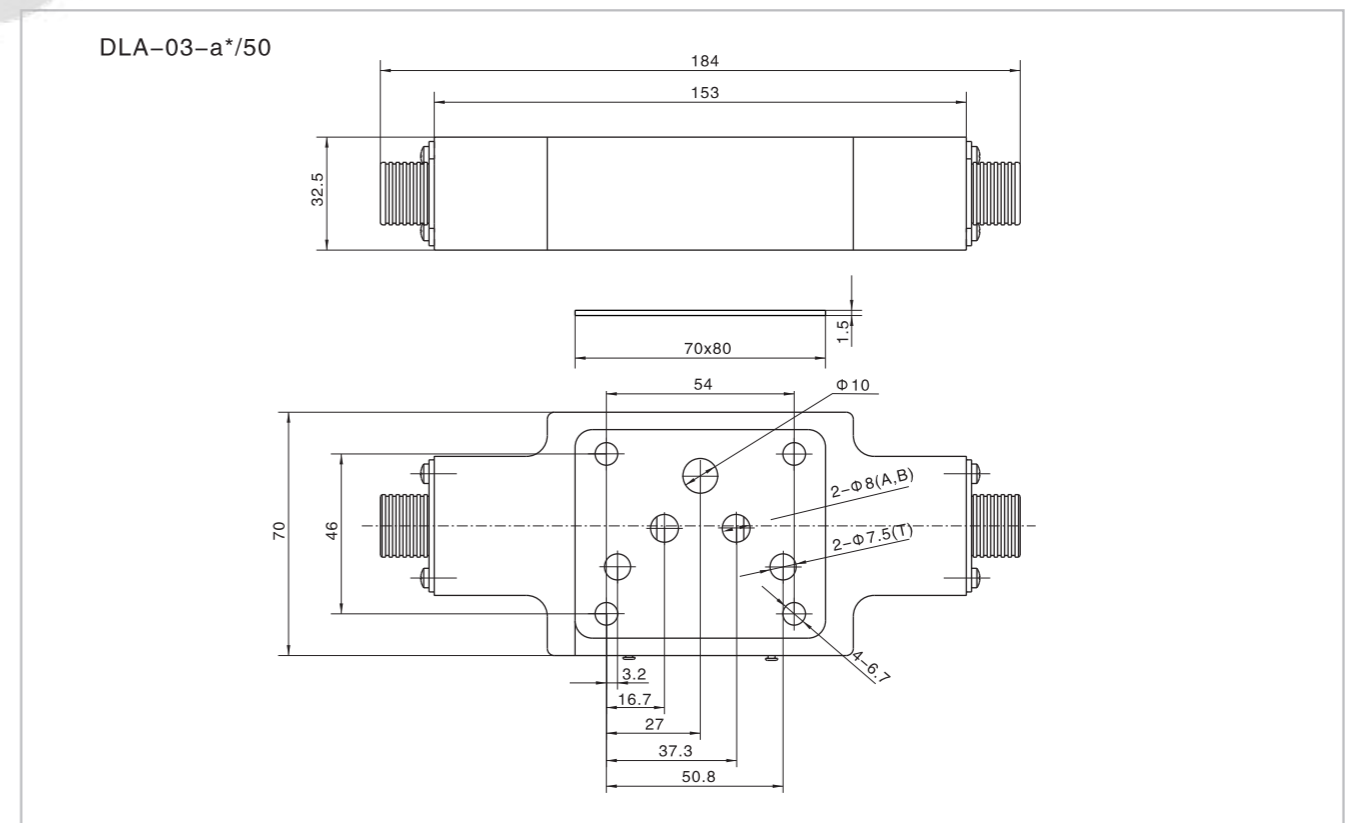
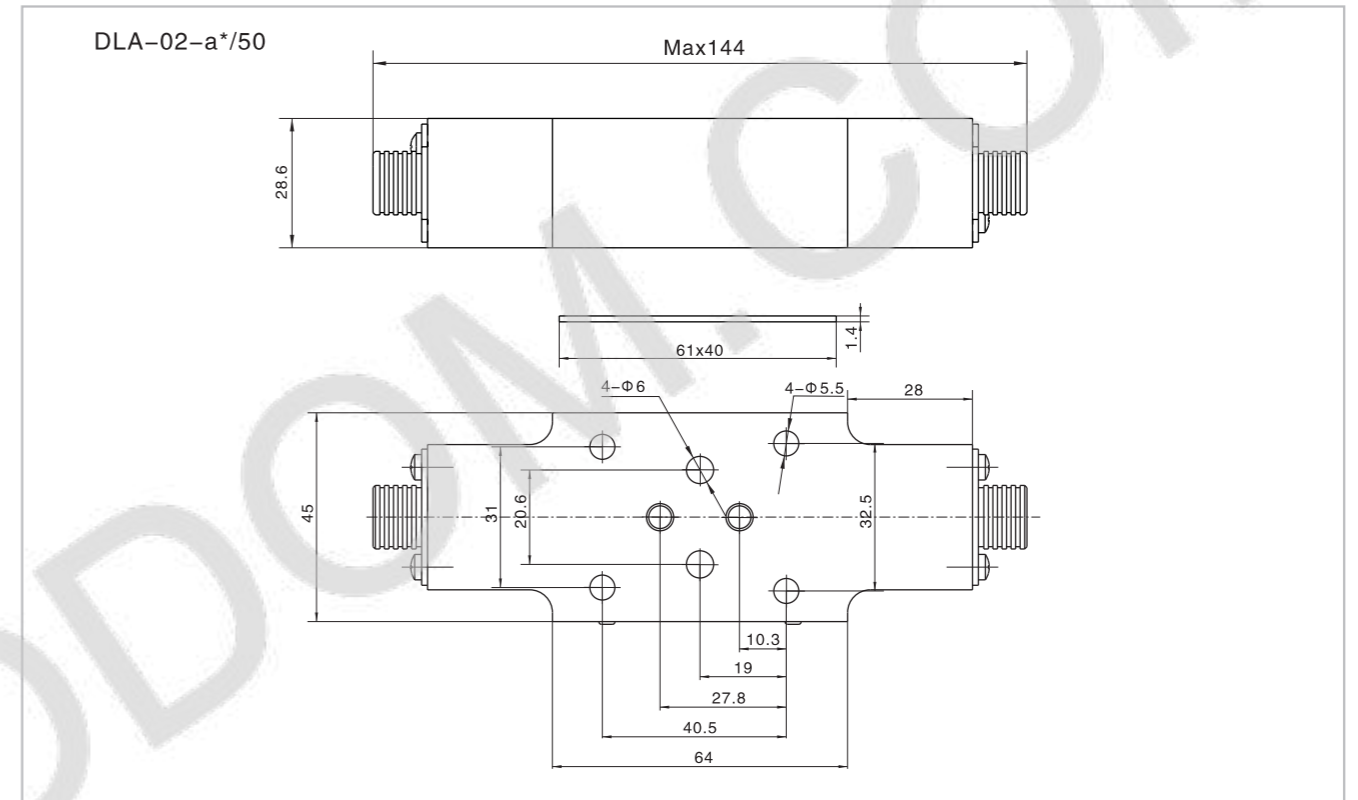

Note: The surface, connecting with the valve, should be Ra0.8 roughness, and 0.01/100mm flatness.

Modular Flow Control Valve

Dimension

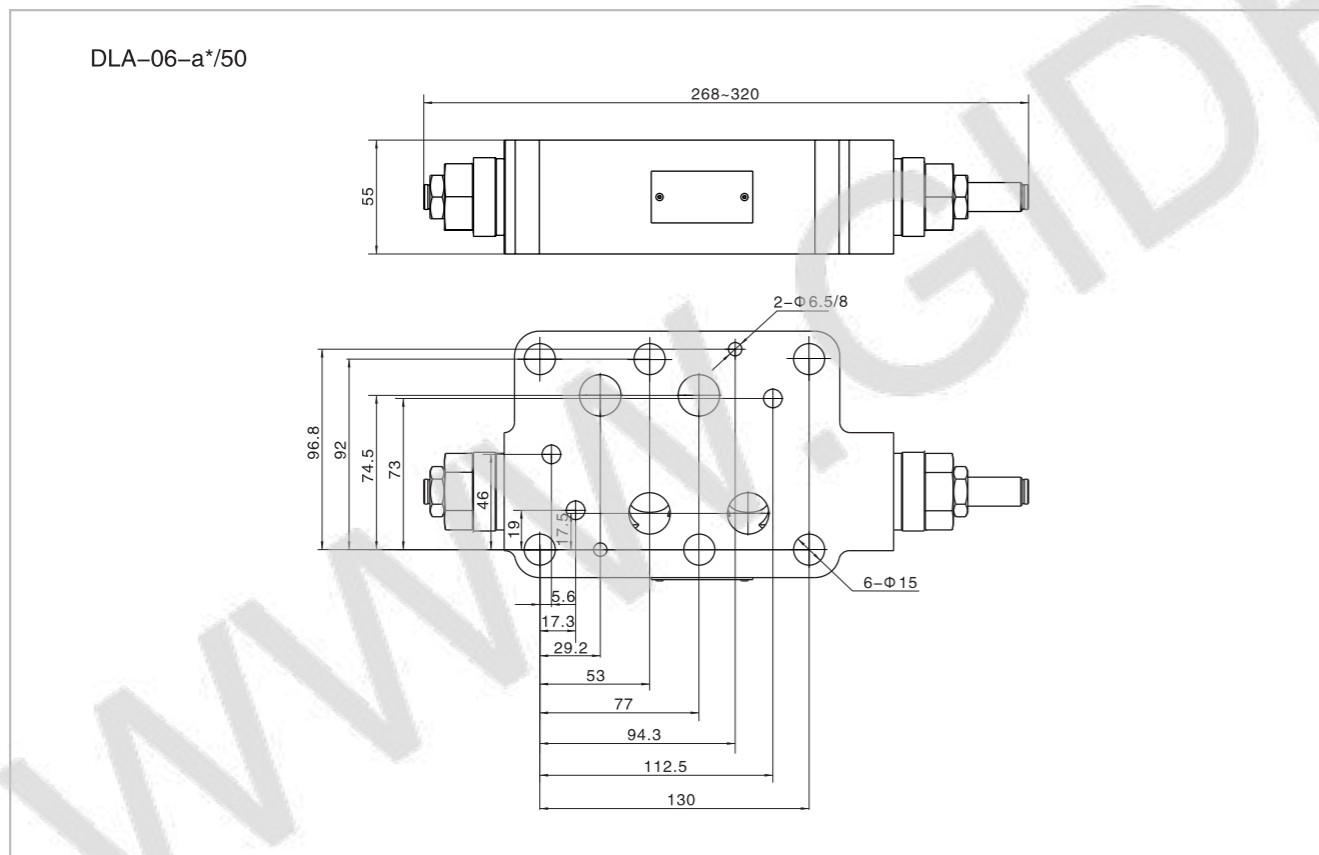
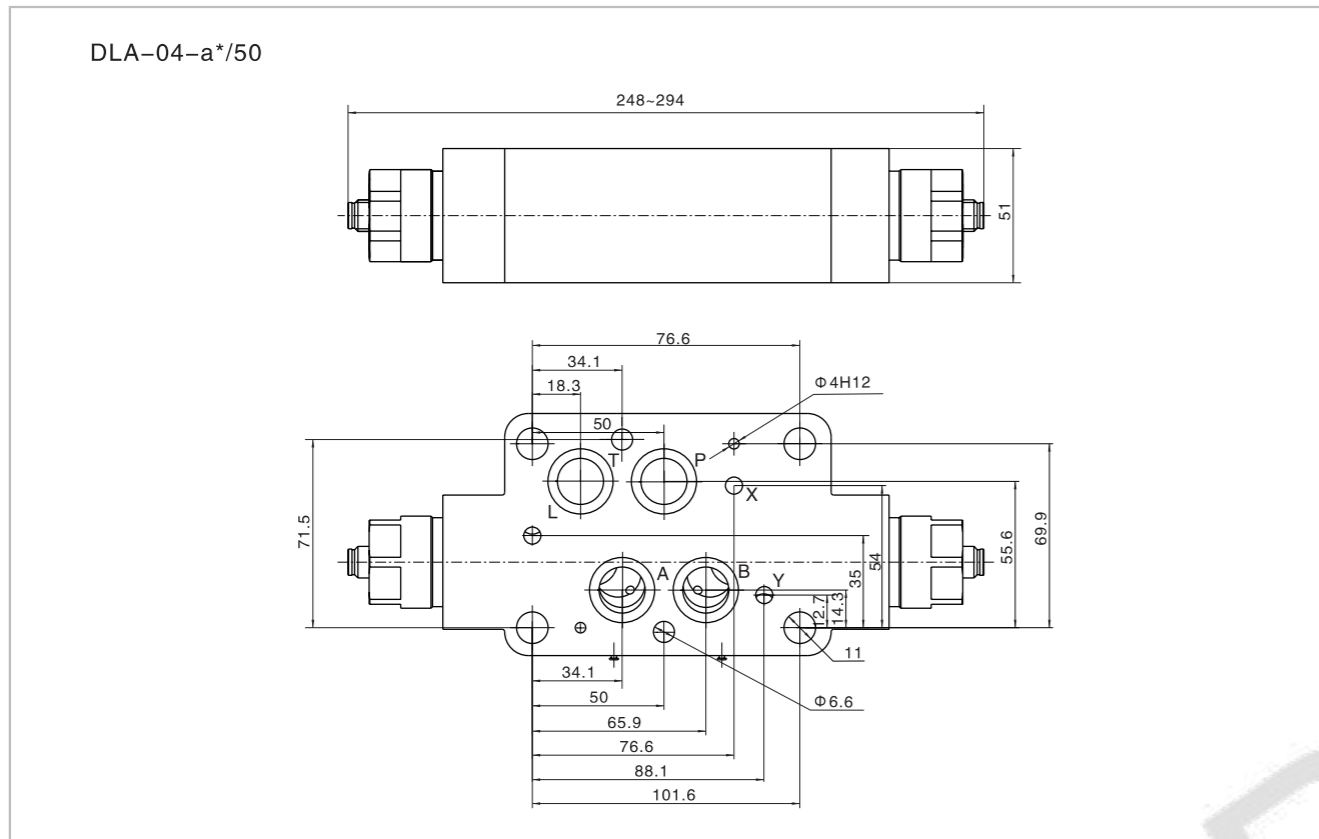

Modular Check Valve

Technical specification



Specification	02	03
Max. working pressure (MPa)	31.5	
Max. Flow (L/min)	40	100
Working fluid	Mineral oil; phosphate-ester	
Fluid temp. (°C)	-20~70	
Viscosity (mm ² /s)	2.8~380	
O pening pressure (MPa)	a:0.05 b:0.25 c:0.4	
Cleanliness	The maximum allowable cleanliness of the oil should be according to 9th degree of Standard NAS1638. It is suggested that the minimum filter rating should be β 10≥75.	

Model description

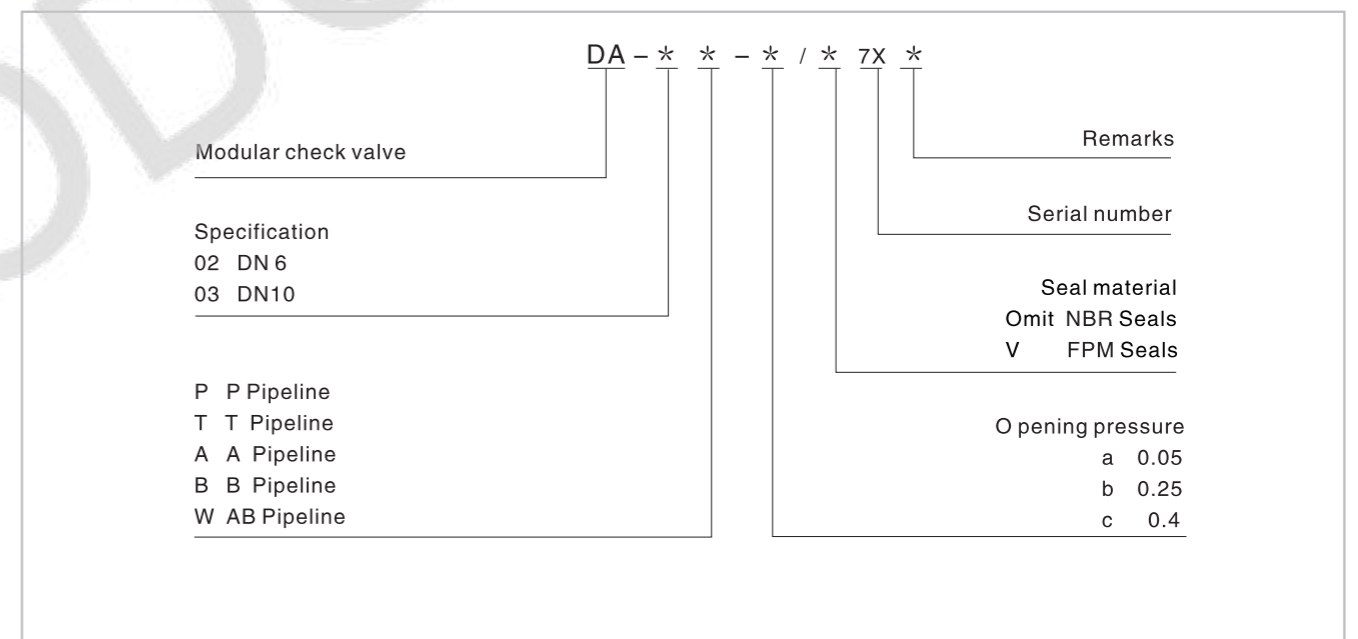

Code symbol

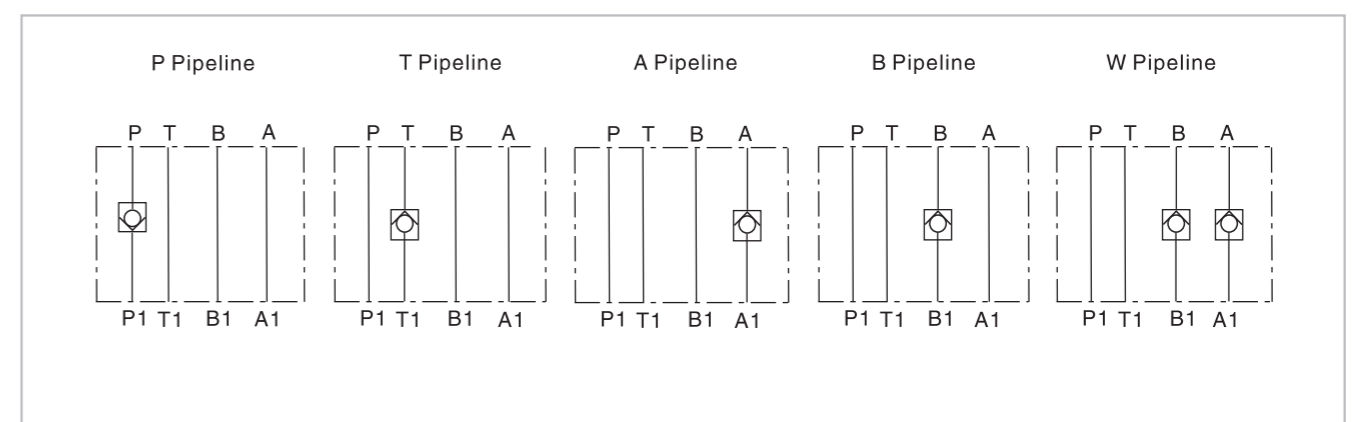

Modular Check Valve

02 External dimensions

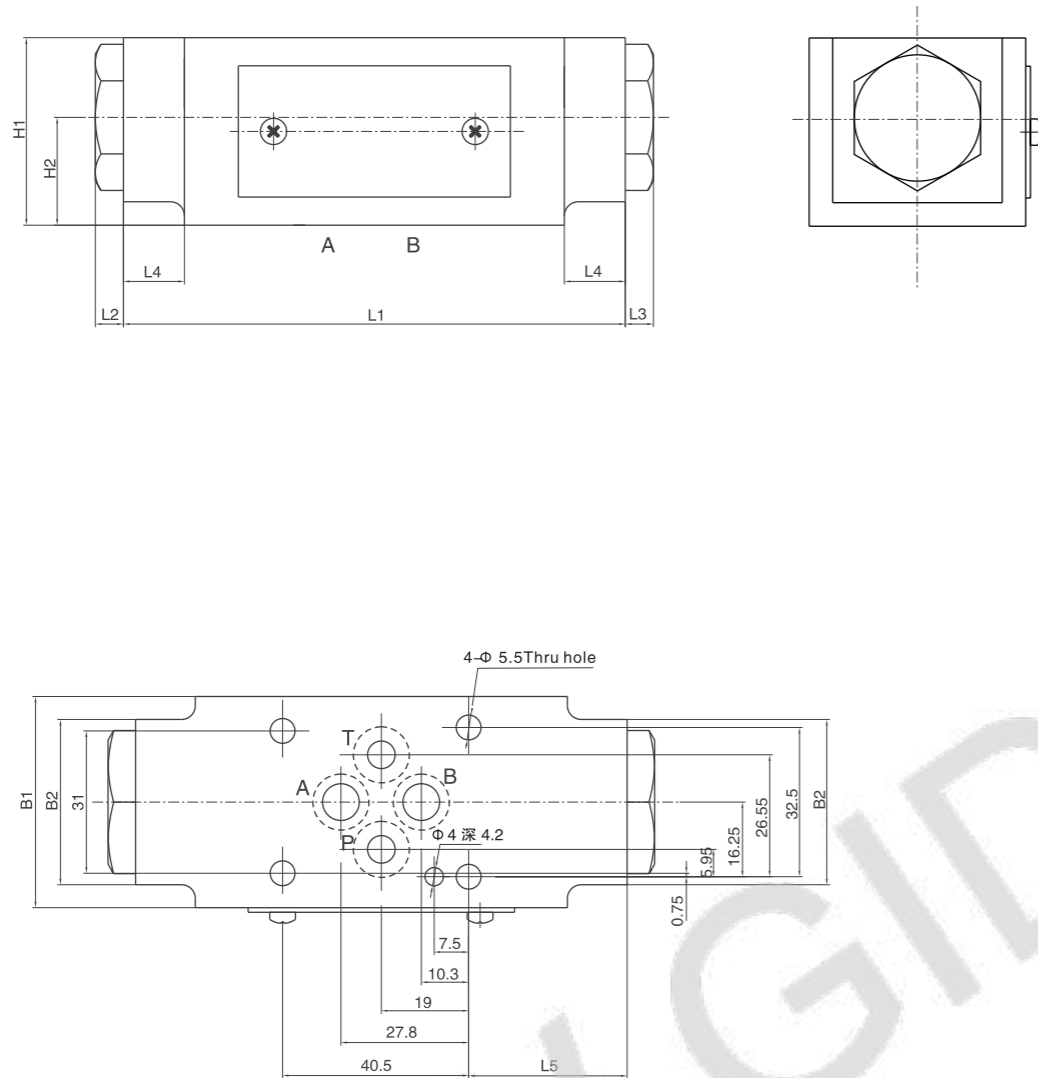

Specification	B1	B2	H1	H2	L1	L2	L3	L4	L5
DA-02-A	46	-	40	20	80	6	-	-	20
DA-02-B	46	-	40	20	80	-	6	-	20
DA-02-P	46	-	40	20	80	-	6	-	20
DA-02-T	46	-	40	20	80	-	6	-	20
DA-02-W	46	36	40	23	107	6	6	13	34.5

Modular Check Valve

03 External dimensions

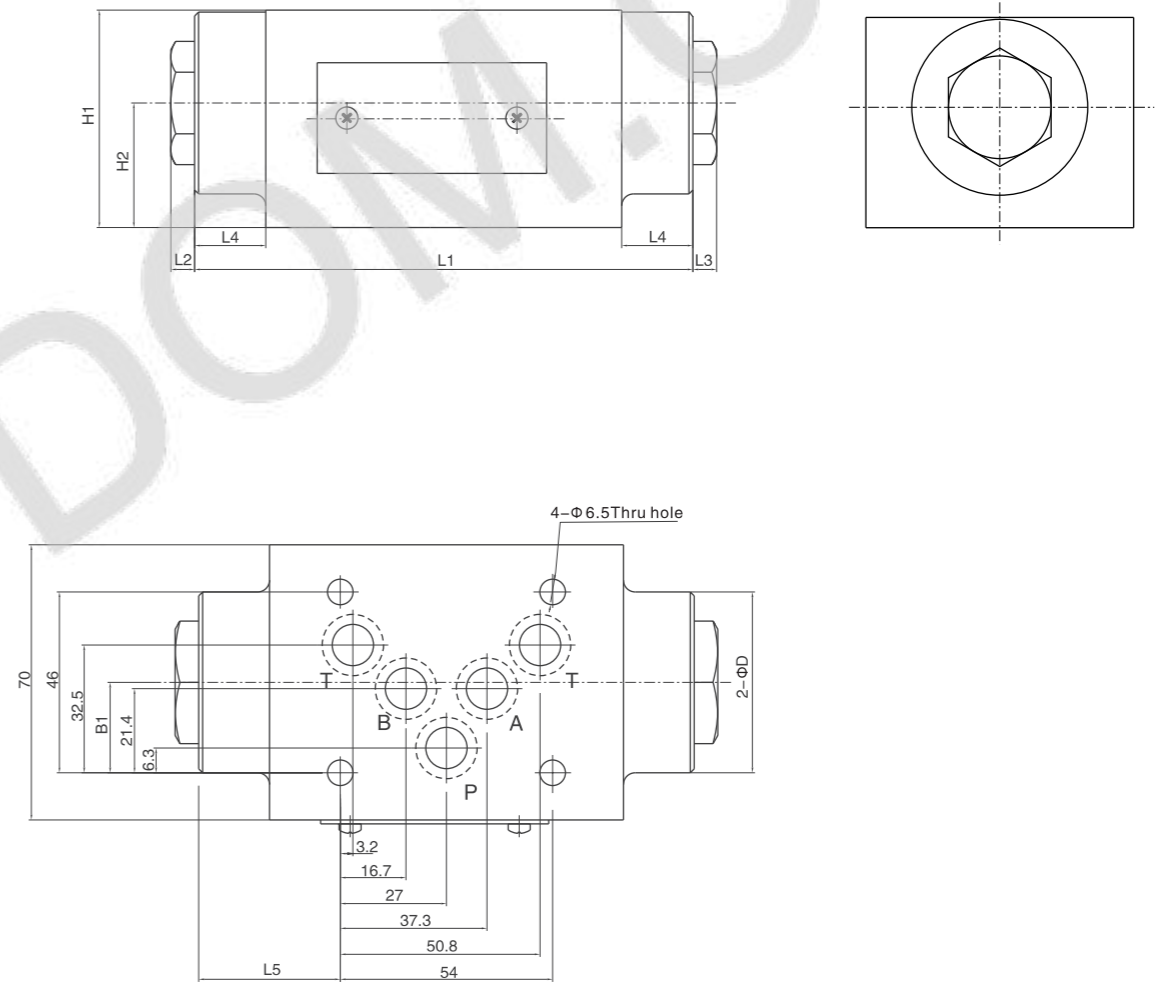

Specification	D	B1	H1	H2	L1	L2	L3	L4	L5
DA-03-A	-	18.5	55	27.5	80	-	6	-	10
DA-03-B	-	18.5	55	27.5	80	6	-	-	16
DA-03-P	-	15.8	55	27.5	80	-	6	-	16
DA-03-T	-	23	55	27.5	100	-	6	-	19.5
DA-03-W	46	23	55	31.5	126	6	6	18	36
DA-03-WT	-	32.5	55	27.5	150	6	6	-	48

Modular Pilot-operated Check Valve

Technical specification



Specification	02	03	04	06
Max. working pressure (Mpa)	31.5			
Max. Flow (L/min)	60	100	200	360
Working fluid	Mineral oil;phosphate-ester			
Fluid temp. (°C)	-20~70			
Viscosity (mm²/s)	2.8~500			
Opening pressure (MPa)	a0.05	b0.25	c0.4	
Cleanliness	The maximum allowable cleanliness of the oil should be according to 9th degree of Standard NAS1638.It is suggested that the minimum filter rating should be $\beta 10 \geq 75$.			

Model description

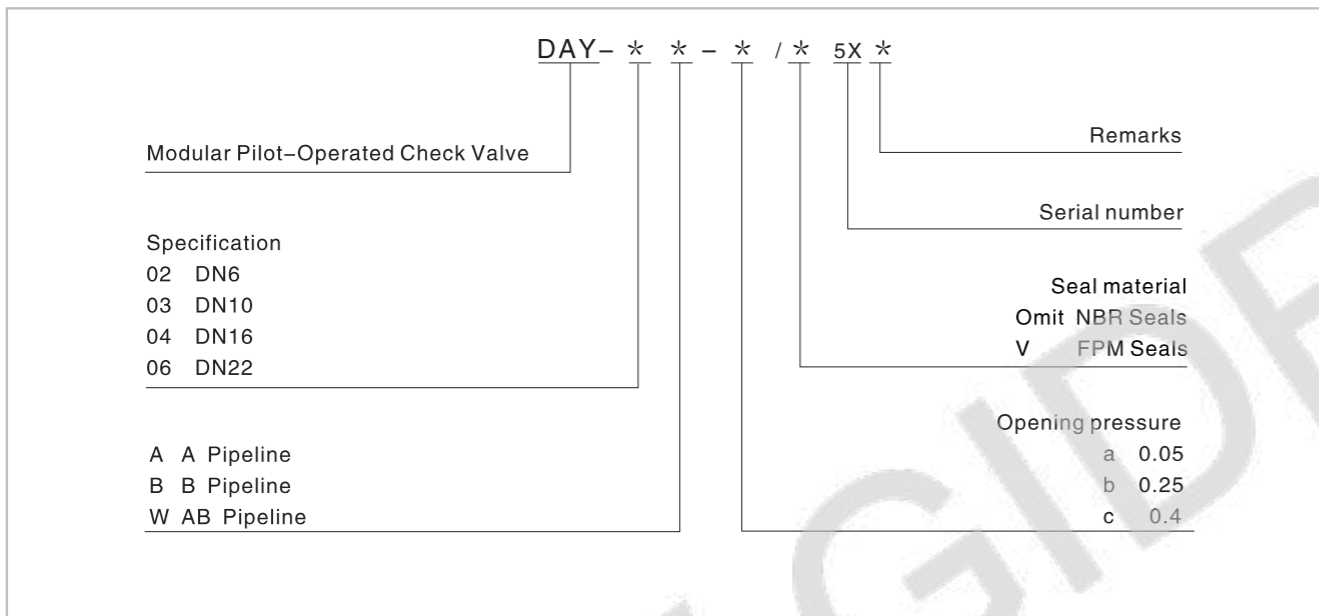

Code symbol

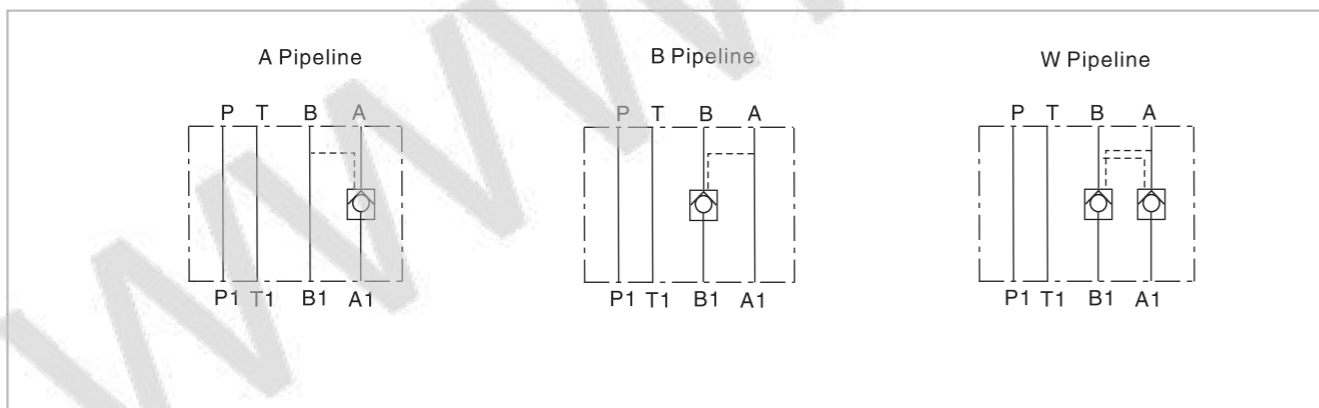

Modular Pilot-operated Check Valve

02 External dimensions

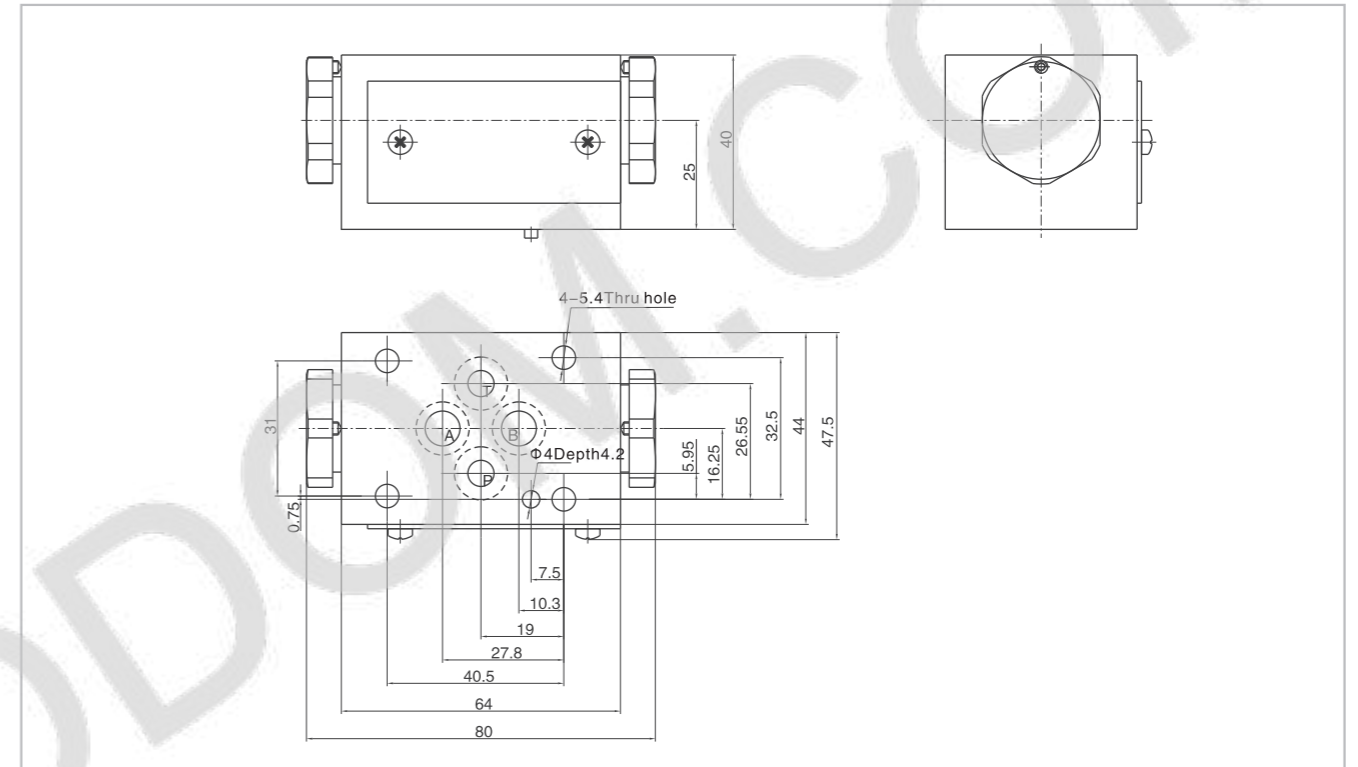

03 External dimensions

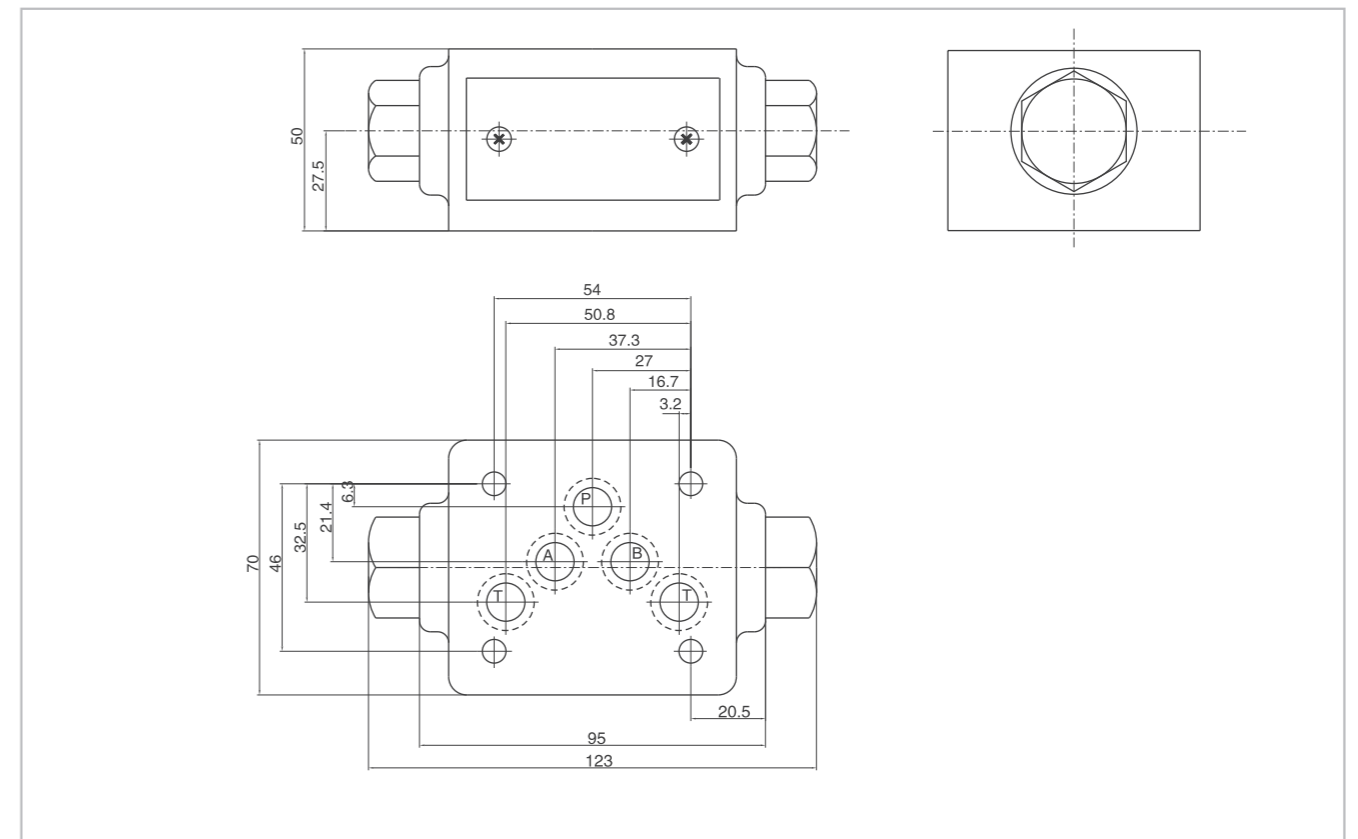

Modular Pilot-operated Check Valve

04 External dimensions

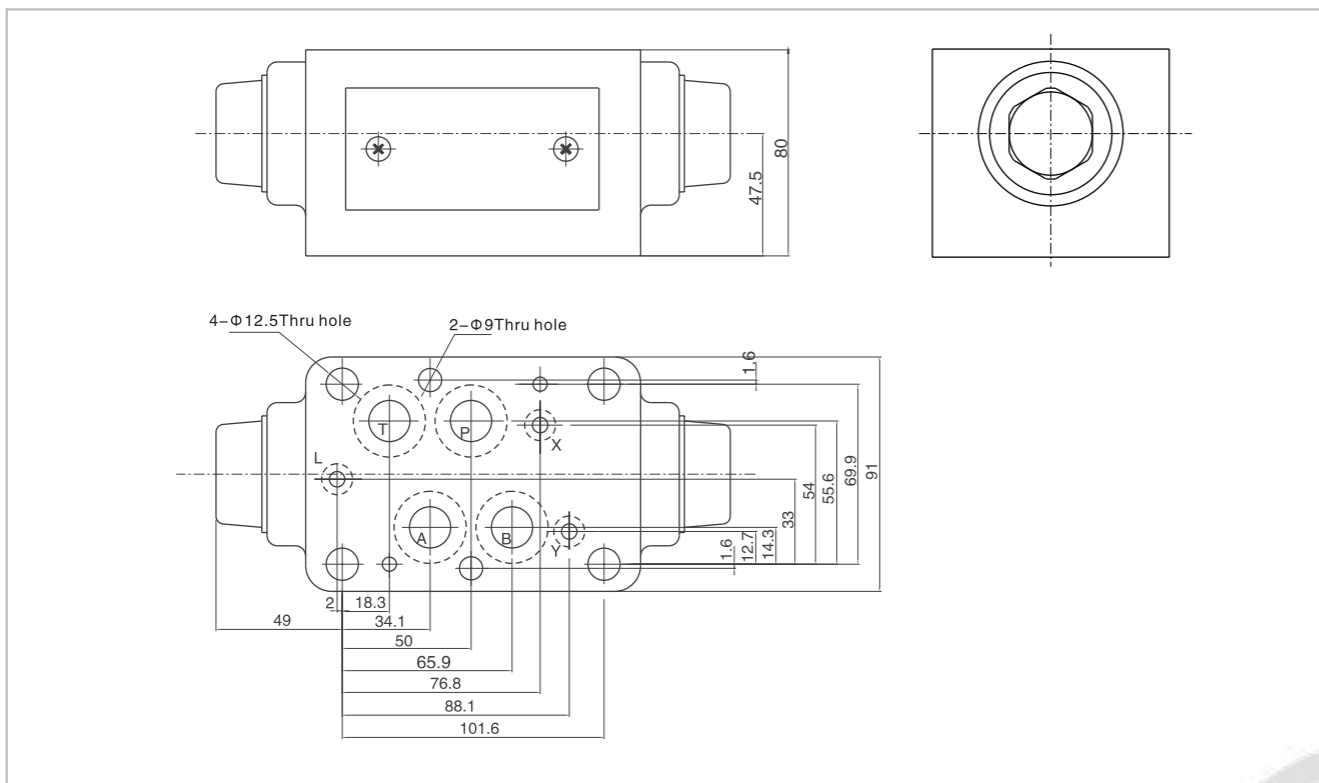

06 External dimensions

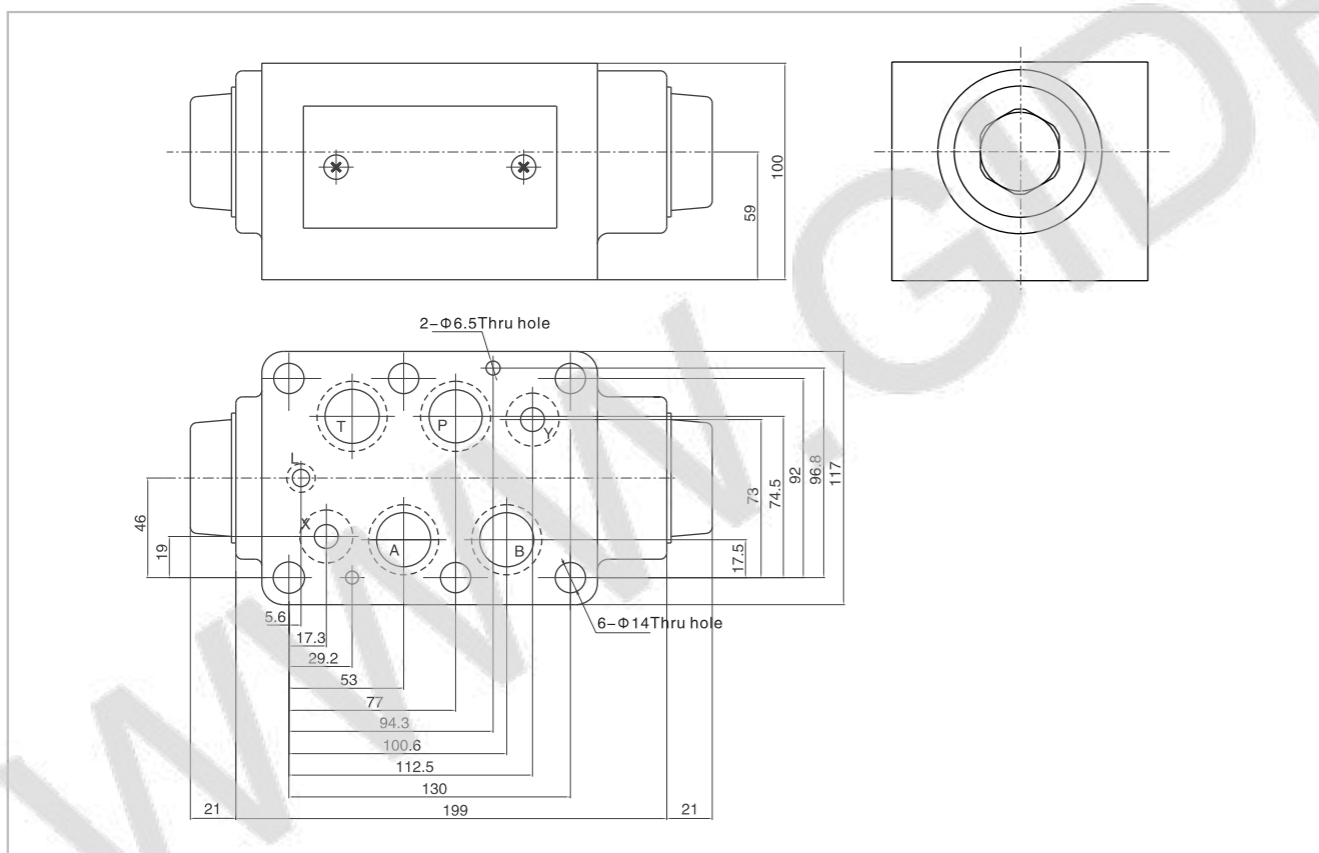

2-position 2-way Subplate/modular Leak-free Direct-operated Solenoid Valve

Technical parameter



Solenoid controls the spool open/closed, the fluid can bi-directionally flows or cut-off. Normally closed.

Technical parameter (Please consult factory if your application is out of below range)

Model	HY-AS6, HY-ZS6, 10	
Mounting	Free, recommended for horizontal installing	
Storage temperature (°C)	-20 ~ +60	
Working temperature (°C)	-20 ~ +50	
Weight (kg)	1.8(ASP6、AS6) 2.8(ZSW6) 7(ZSW10)	

Hydraulic parameter

Max working pressure (MPa)	35	
Specifications	NG6	NG10
Max flow rate (L/min)		
Working fluid	Mineral hydraulic oil, phosphate	
Fluid temp range (°C)	-20~+70	
Viscosity range (mm ² /s)	12~320	
Minimum fluid cleanliness	Maximum permissible degree of pressure fluid contamination to NAS 1638 to class 9 recommended filter β ₁₀ ≥ 75.	

Hydraulic symbol

Voltage type	Direct current	
Adaptable voltage (V)	24	
Allowed residue (%)	< 5	
Float Voltage step-down (%)	± 10	
IP class	IP65	

2-position 2-way Subplate/modular Leak-free Direct-operated Solenoid Valve

Ordering code

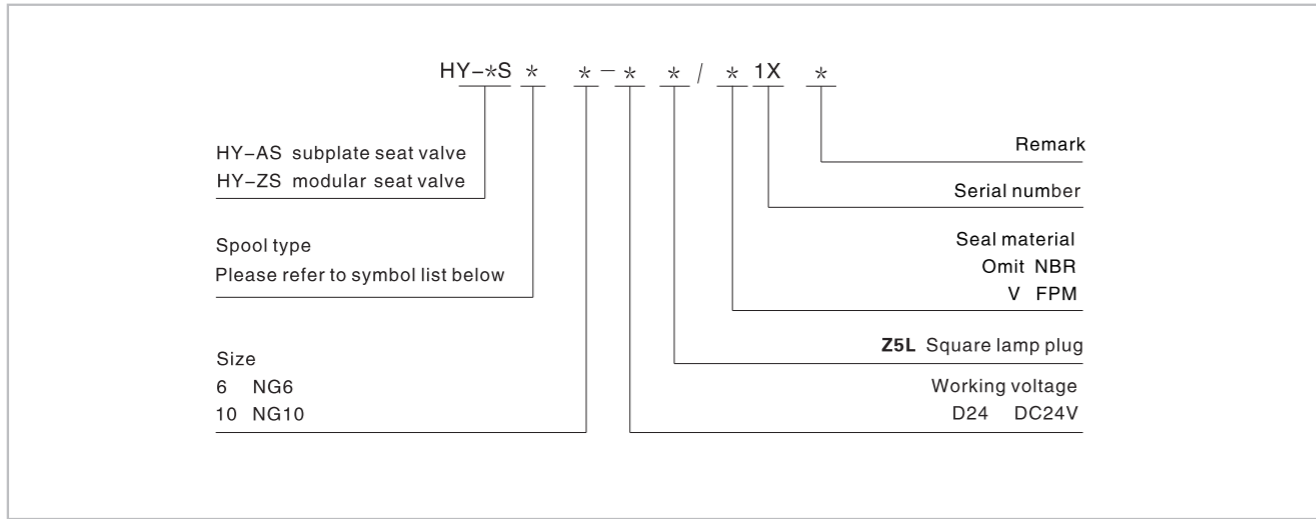

Hydraulic symbol

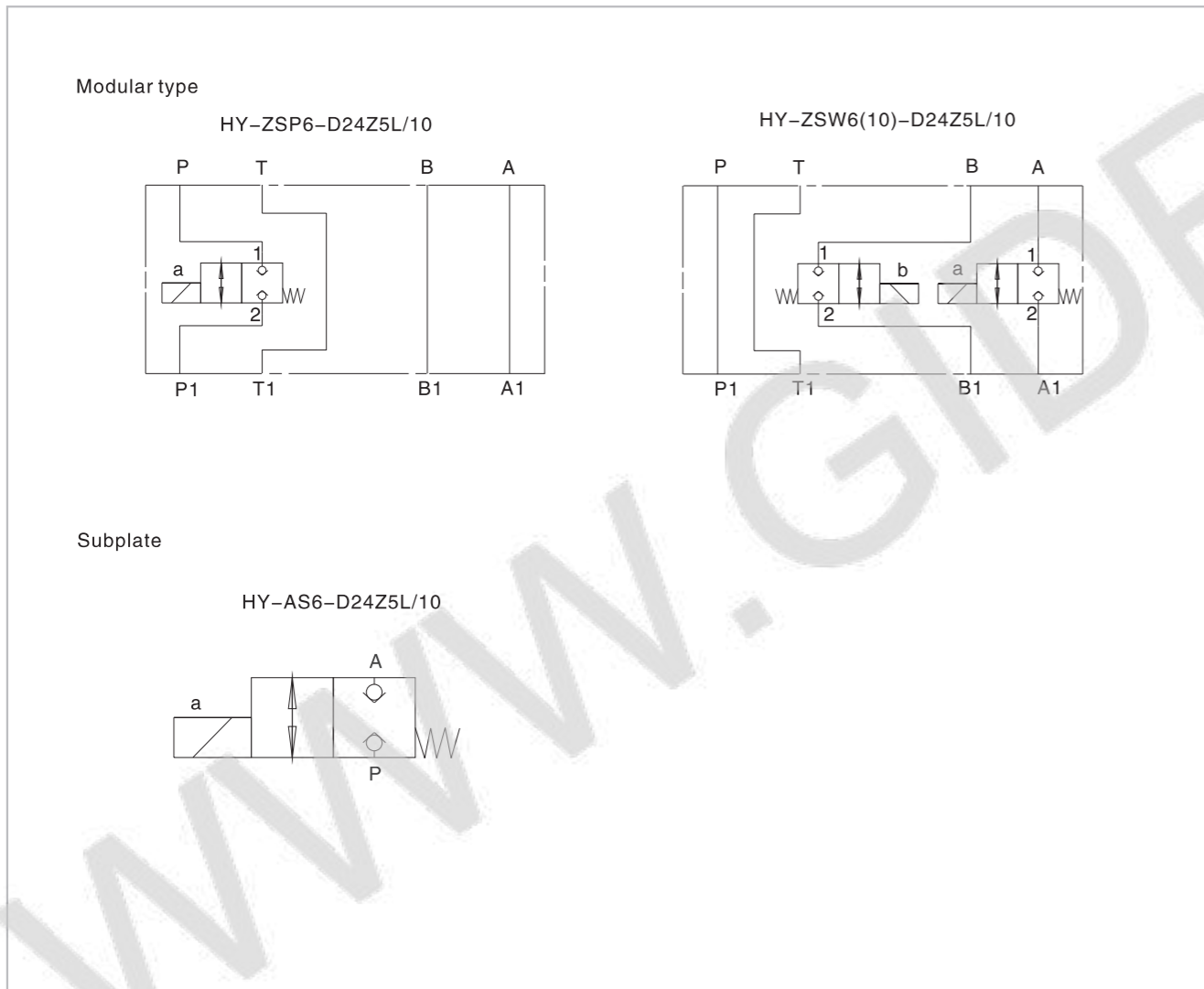

2-position 2-way Subplate/modular Leak-free Direct-operated Solenoid Valve

NG6 modular type performance curve (Oil HLP46 tested at 40°C ± 5°C)

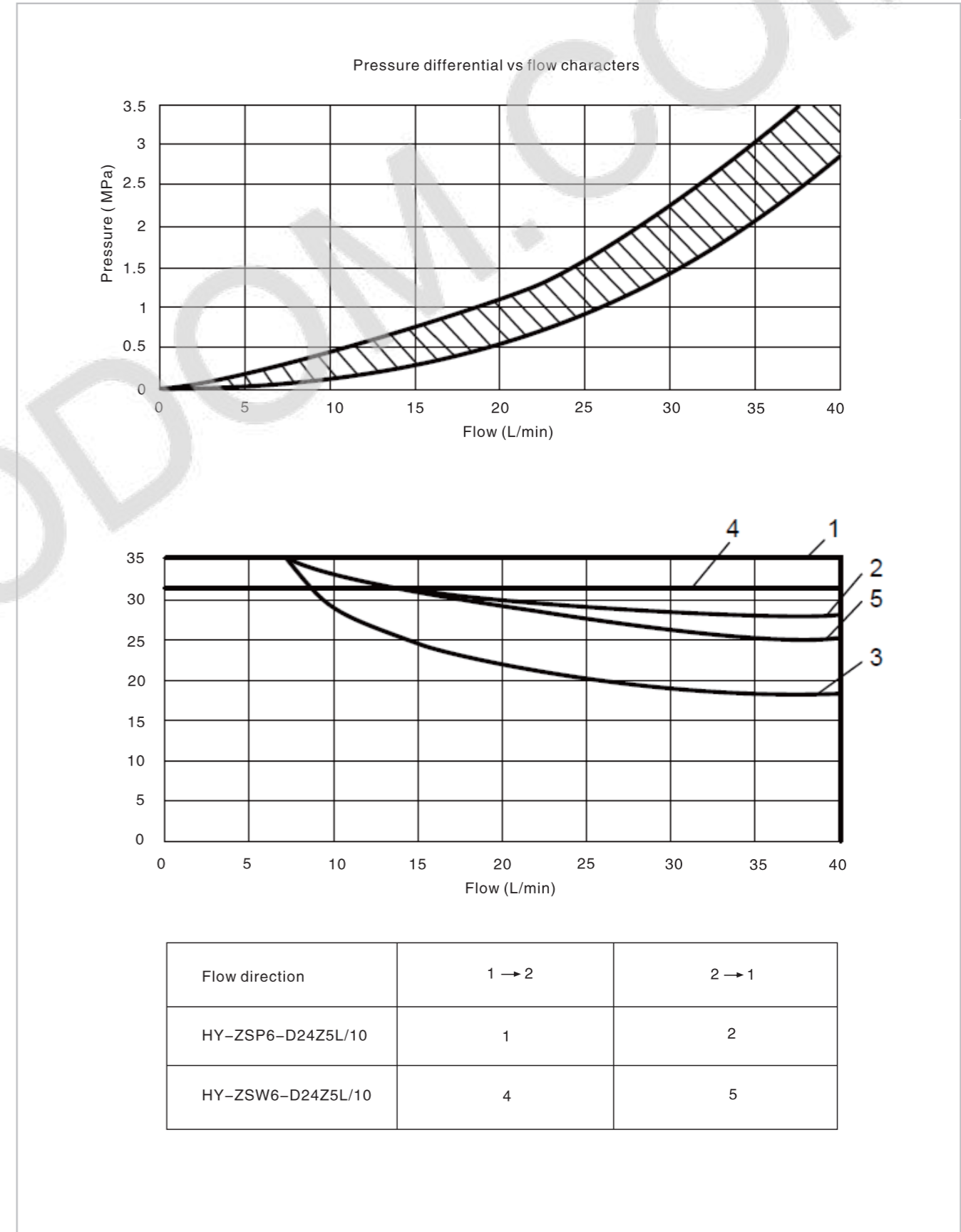

2-position 2-way Subplate/modular Leak-free Direct-operated Solenoid Valve

External dimension

HY-ZSP6-D24Z5L/10

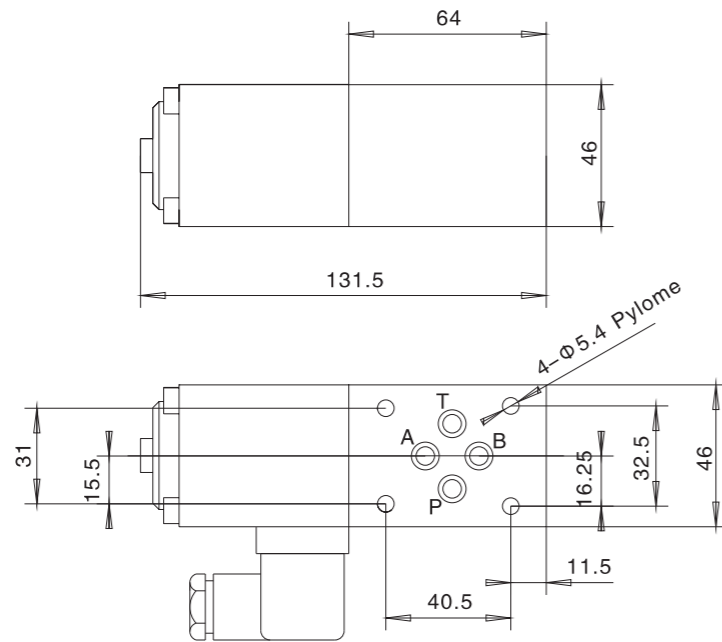

HY-ZSW6(10)-D24Z5L/10

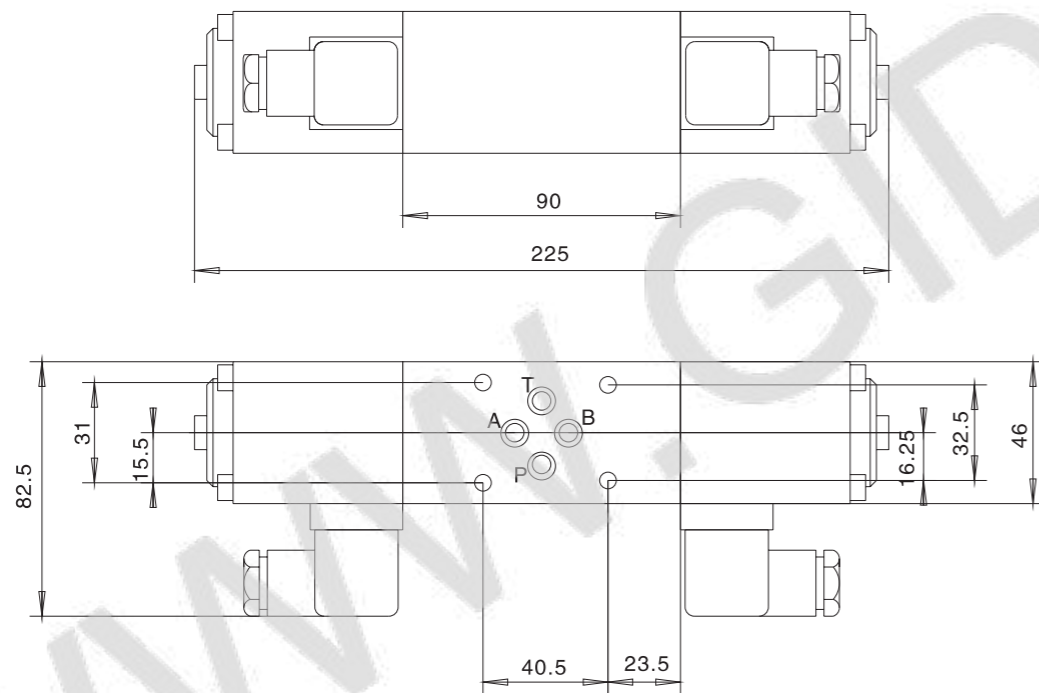

2-position 2-way Subplate/modular Leak-free Direct-operated Solenoid Valve

Sub-plate mounting

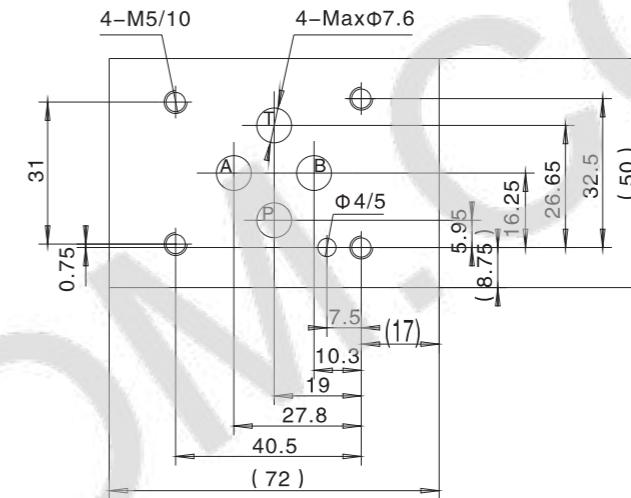

Note:

1. It can be mounted in any direction, but horizontal installation is recommended.
2. The mounting surface must be flat within 0.01/100mm and roughness Ra 0.8

NG10 modular type performance curve (Oil HLP46 tested at 40 ± 5°C)

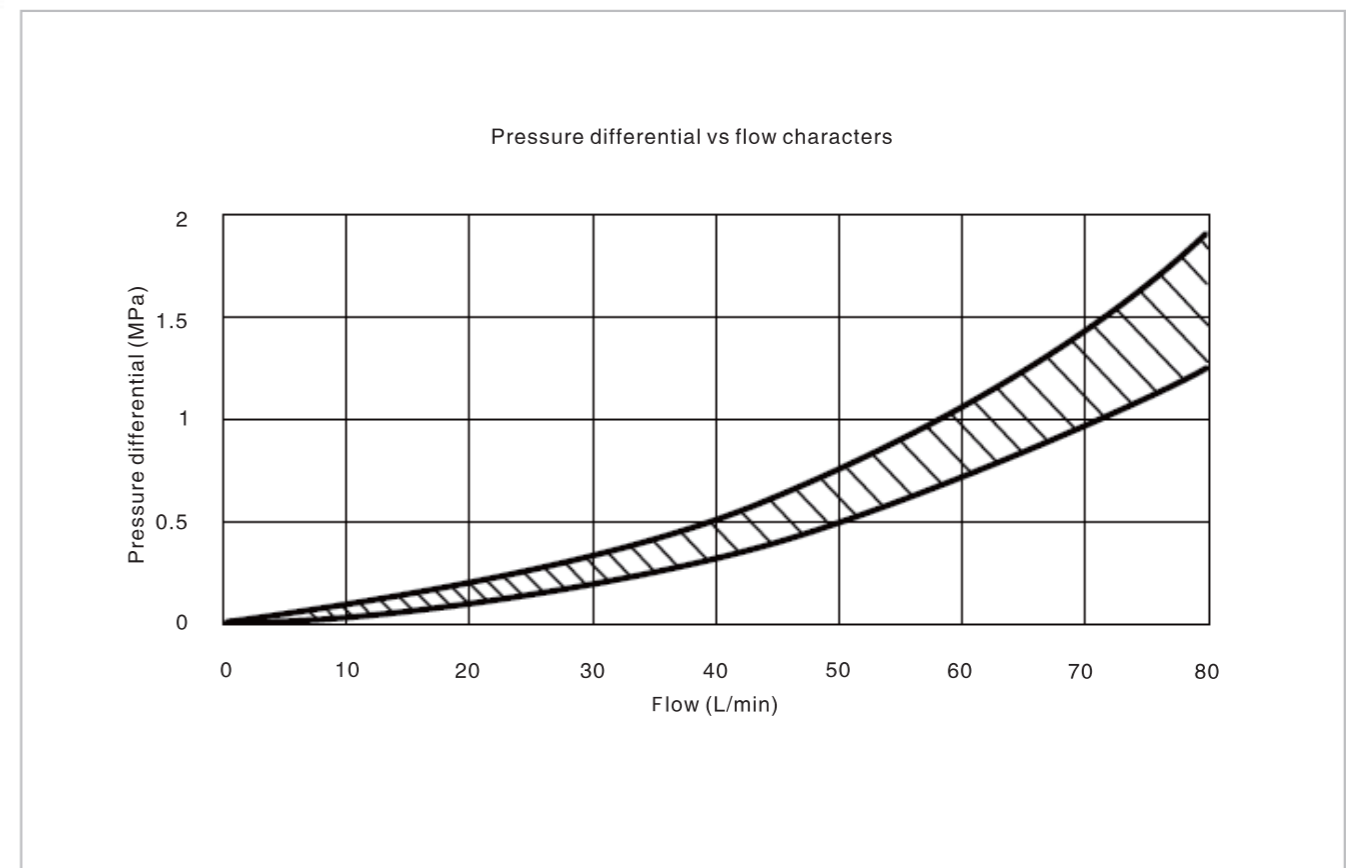

2-position 2-way Subplate/modular Leak-free Direct-operated Solenoid Valve

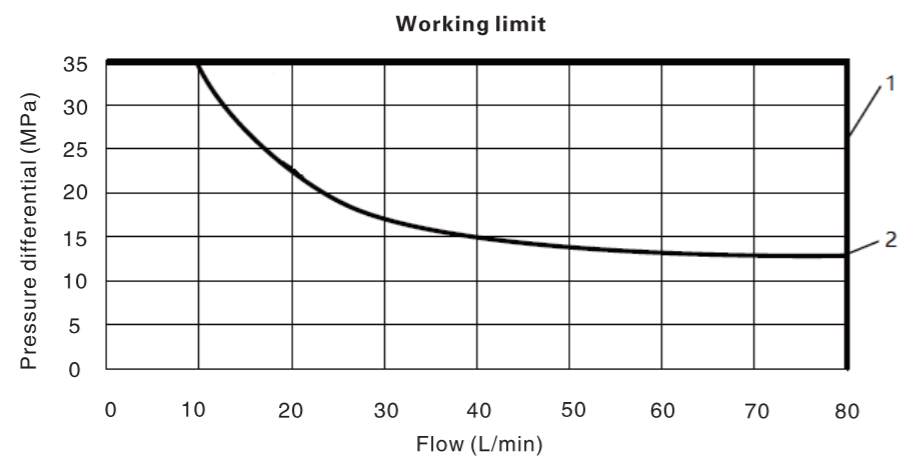

Flow direction	1 → 2	2 → 1
HY-ZSW10-D24Z5L/10	1	2

External dimension

HY-ZSW10-D24Z5L/10

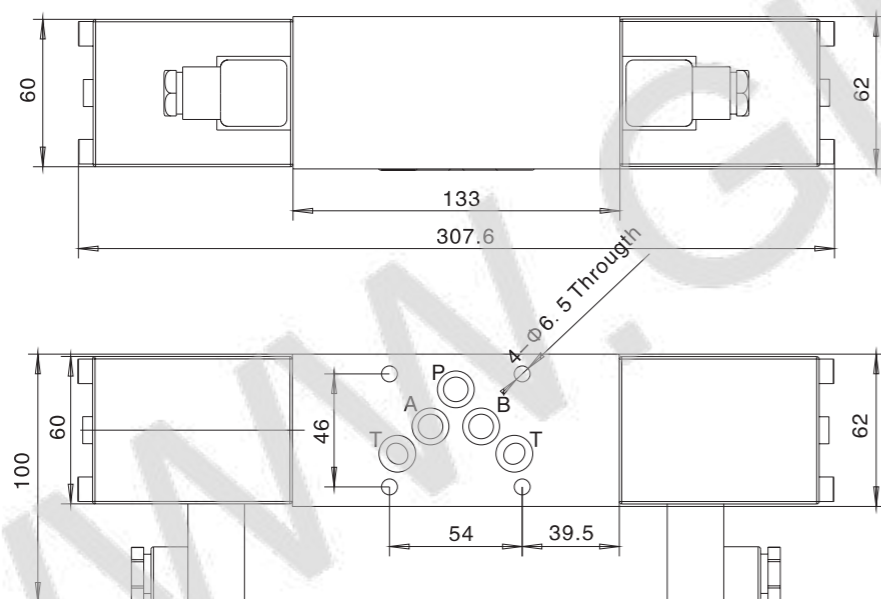

2-position 2-way Subplate/modular Leak-free Direct-operated Solenoid Valve

Sub-plate mounting

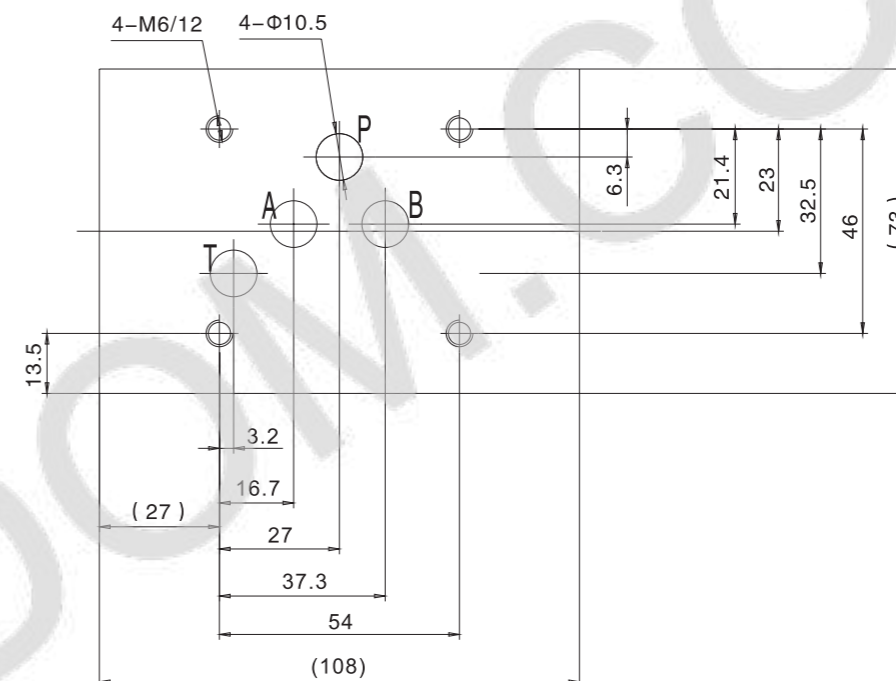

Note:

1. It can be mounted in any direction, but horizontal installation is recommended.
2. The mounting surface must be flat within 0.01/100mm and roughness Ra 0.8

NG6 modular type performance curve (Oil HLP46 tested at 40 ± 5°C)

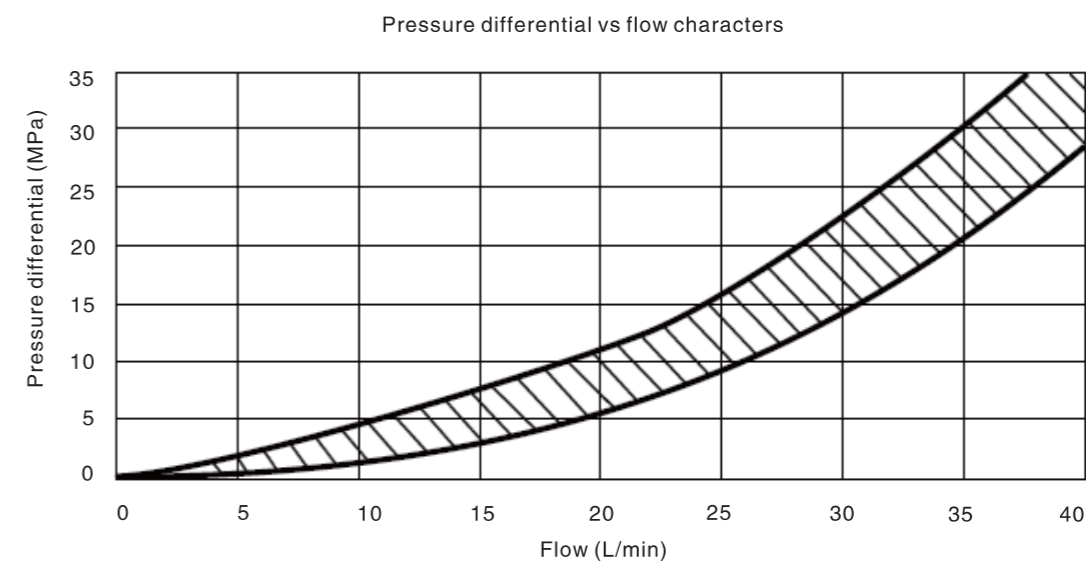

2-position 2-way Subplate/modular Leak-free Direct-operated Solenoid Valve

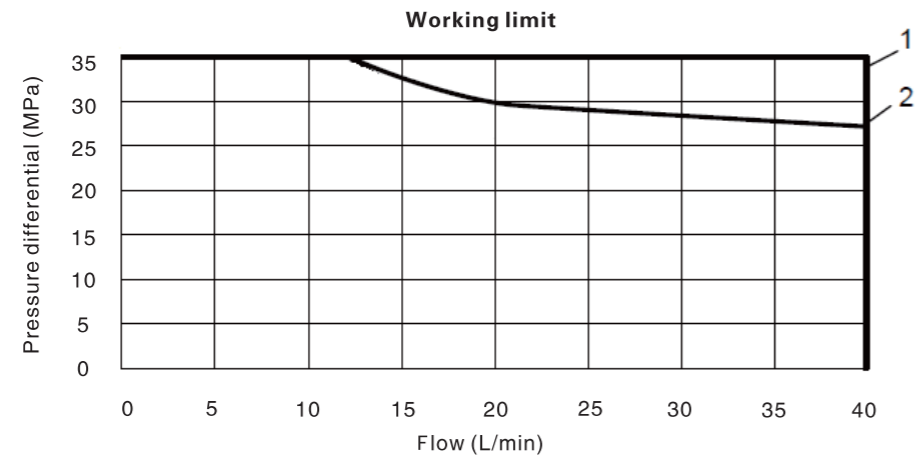

Flow direction	P → A	A → P
HY-AS6-D24Z5L/10	1	2

External dimension

HY-AS6-D24Z5L/10

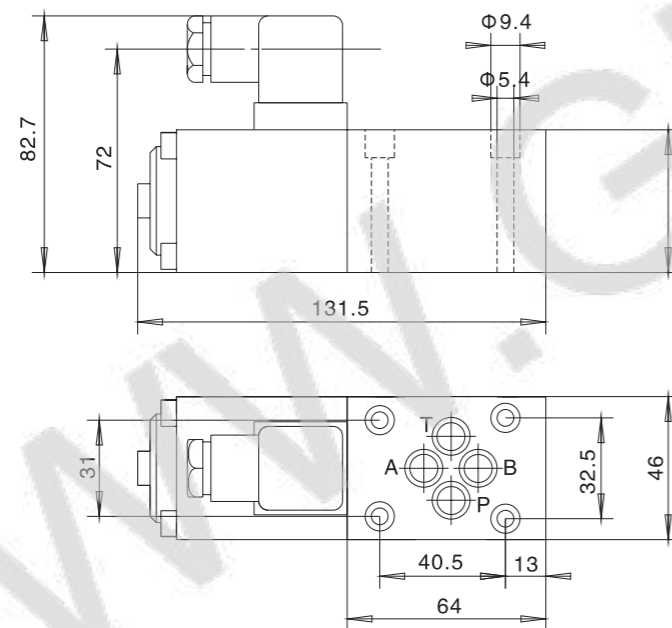

2-position 2-way Subplate/modular Leak-free Direct-operated Solenoid Valve

Sub-plate mounting

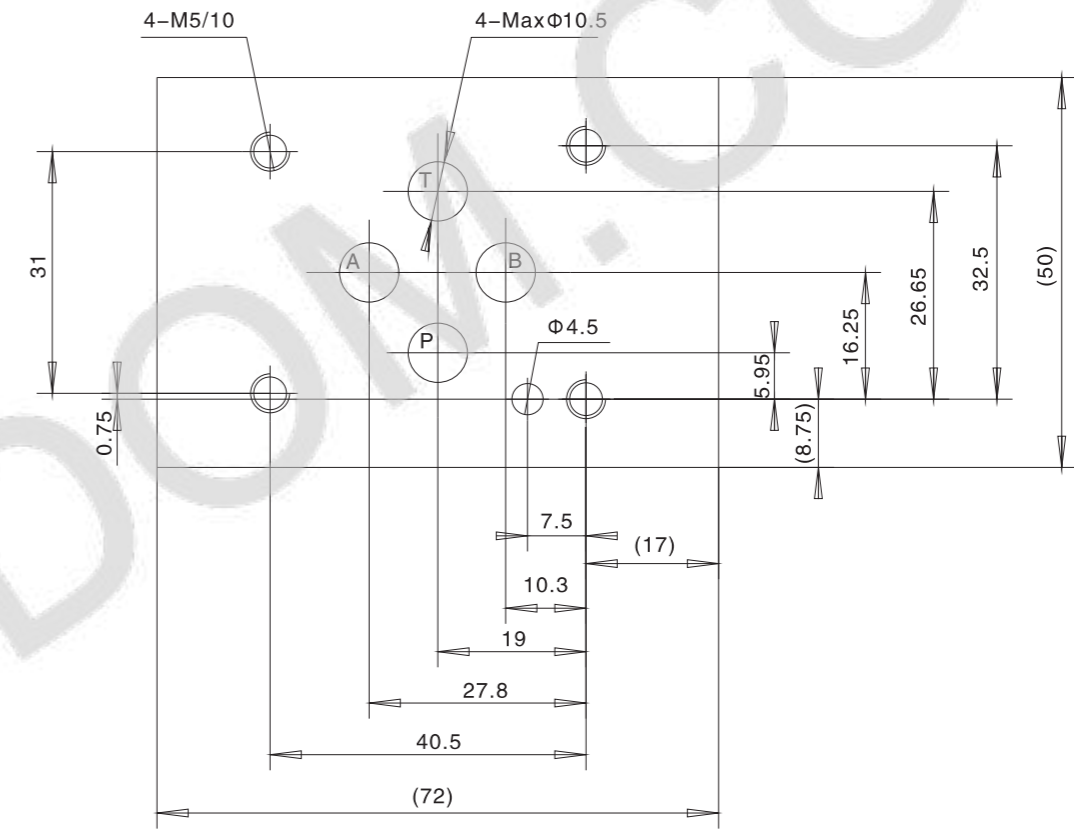

Mounting screw	Qty	Tighten torque
M5 × 45-10.9	4	9Nm

Note:

1. It can be mounted in any direction, but horizontal installation is recommended.
2. The mounting surface must be flat within 0.01/100mm and roughness Ra 0.8

Modular Pressure-compensated Valve



It's mounted between proportional valve and pump, to keep the flow unchanged.

Technical parameter (please consult factory if your application is out of below range)

Model	HYTV2-02	
Mounting	Free, recommended for horizontal installing	
Working temperature (°C)	-20~+70	
Weight (kg)	1.0	

Hydraulic parameter

Max working pressure (Mpa)	31.5	
Max flow rate (L/min)	35	
Control pressure differential (Mpa)	1	
Working fluid	Mineral hydraulic oil, phosphate	
Fluid temp range (°C)	-20~+75	
Viscosity range (mm ² /s)	20~380	
Minimum fluid cleanliness	Maximum permissible degree of pressure fluid contamination to NAS 1638 to class 9 Recommended filter $\beta_{10} \geq 75$.	

Modular Pressure-compensated Valve

Ordering code

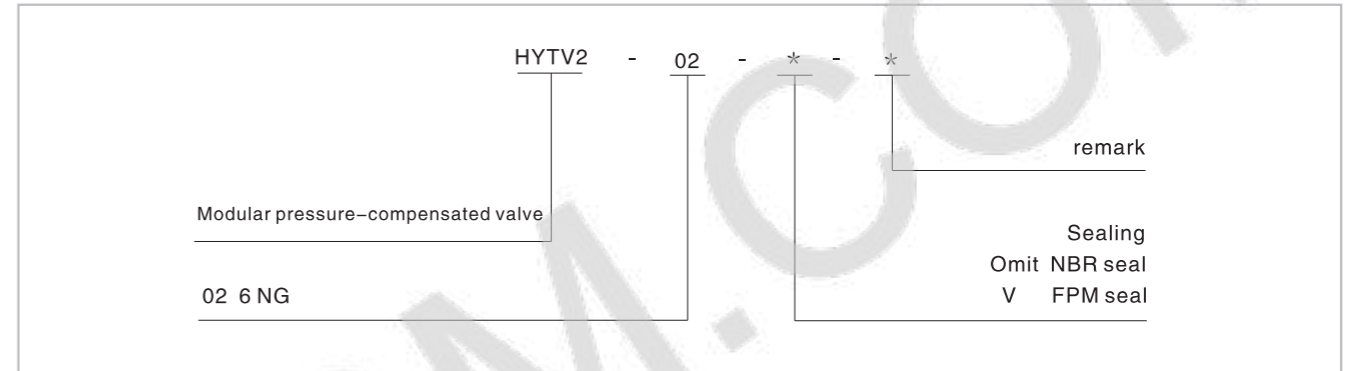

Hydraulic symbol

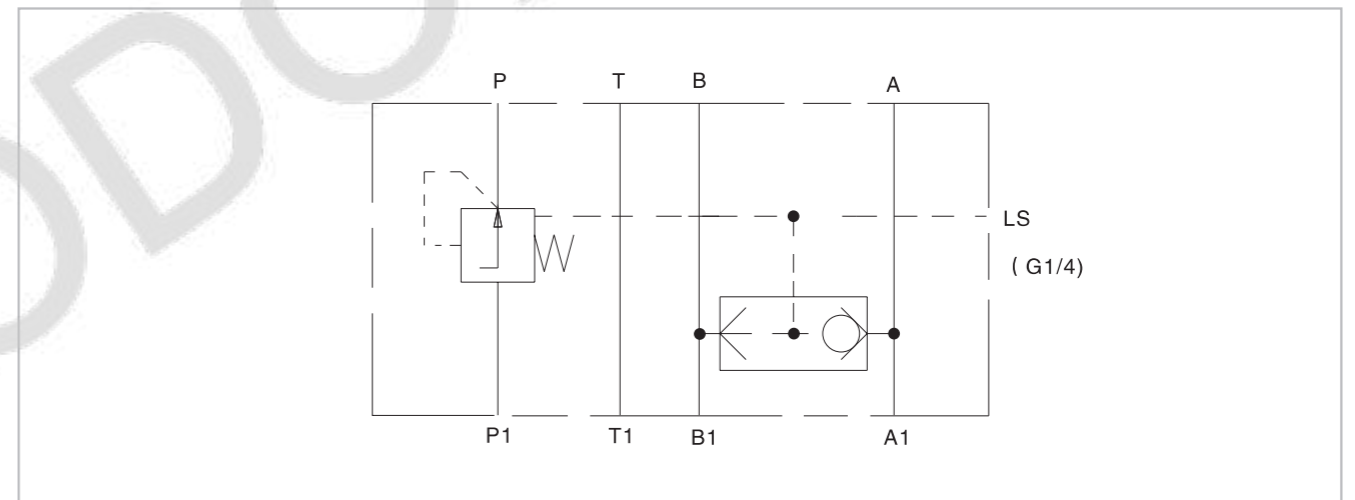

Performance curve

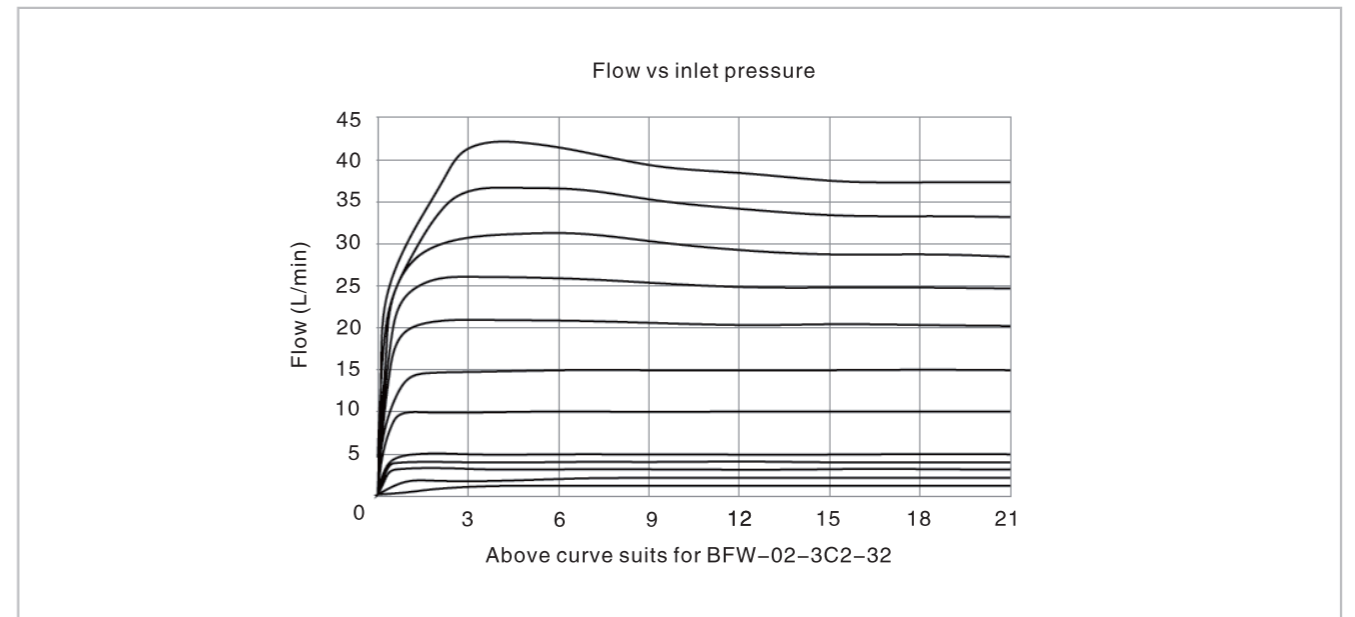

Modular Pressure-compensated Valve

HOYEA

Manifolds

External dimension

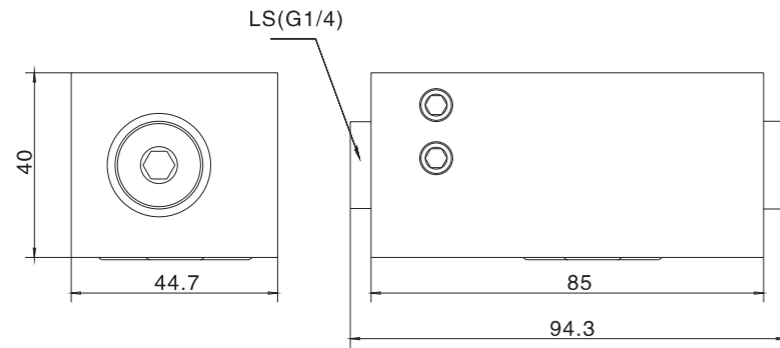

Sub-plate mounting

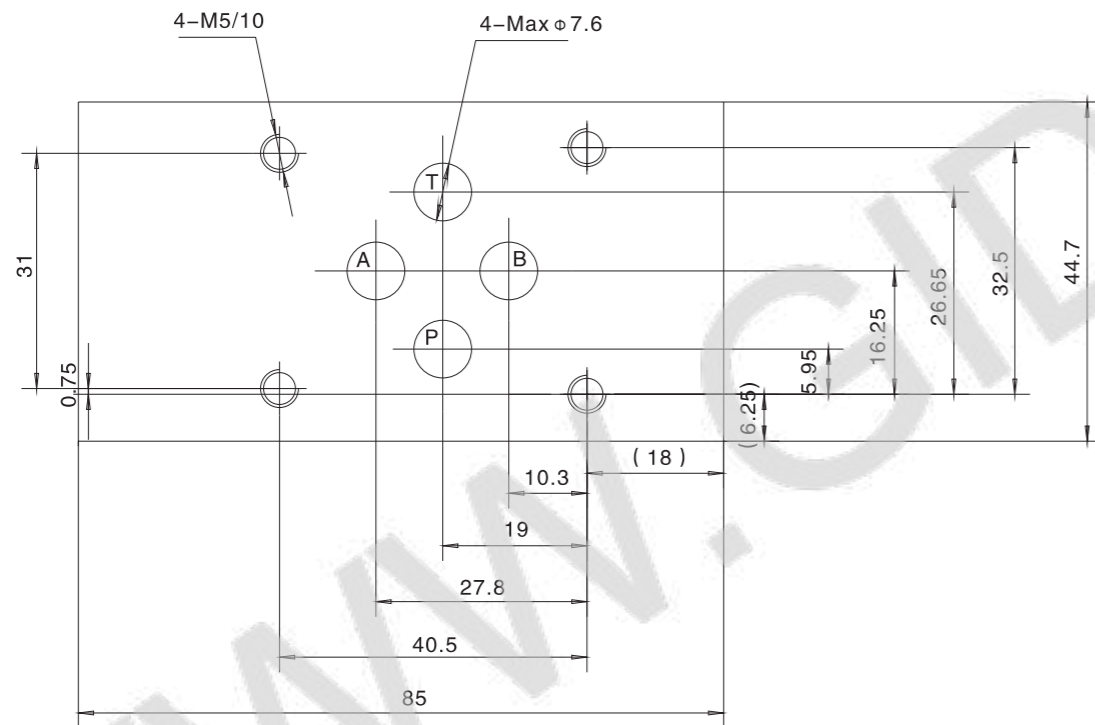

Note:

- 1. It can be mounted in any direction, but horizontal installation is recommended.
- 2. The mounting surface must be flat within 0.01/100mm and roughness Ra 0.8



D03 Standard Flow Parallel Circuit Manifold

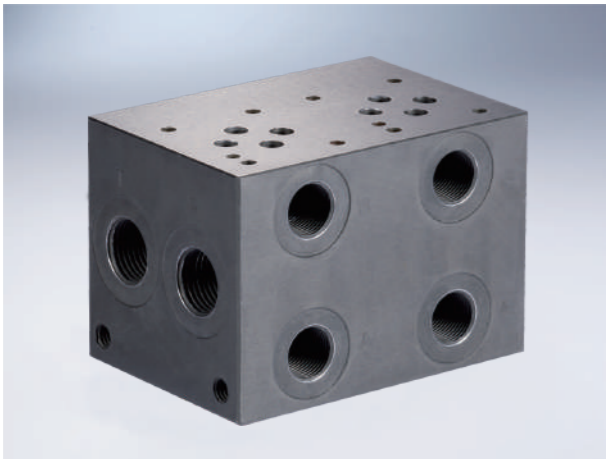

Ordering information

HY* D03 P * 2 * / * / 1X

A Aluminum 7A04 max. working pressure 20.7Mpa
D Ductile Iron 45# max. working pressure 31.5Mpa

Valve Pattern 03 NG 6

Parallel Circuit Standard Flow

No. of Stations
01-16

Valve Spacing
2.13 inch [54.0 mm]

Serial number

Omit	cavities not required
C	One Common cavity: C-10-2 (P in nose)
S	One Sun Cavity: T-10A (P in nose)

Port Threads	P, T	A, B	GA
P NPT(Z)	0.5	0.38	0.25
S SAE	-10	-8	-6
B BSP(G)	0.5	0.38	None
M M	M22x1.5	M18x1.5	None

Code Symbol

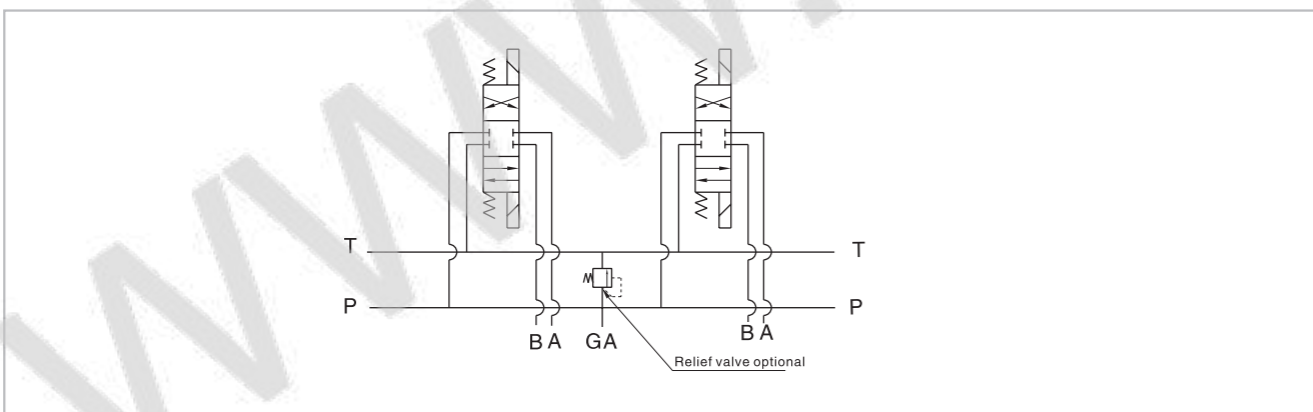

D03 Standard Flow Parallel Circuit Manifold

External dimensions

Port code	Valve mounting thread.	Manifold mounting thread.
P,S	#10-24 UNCx 0.63[16]DP	0.31-18 UNCx 0.44[11.1] DP
B,M	M5 ISO 6Hx 0.63[16]DP	M8 ISO 6Hx 0.44[11.1] DP

No. of stations	* 01	02	03	04	05	06	07	08	09	10	11	12	13	14	15	16
"A" length inch (mm)	2.13 [54.0]	4.25 [108.0]	6.38 [162.1]	8.50 [215.9]	10.63 [270.0]	12.75 [323.9]	14.88 [378.0]	17.00 [431.8]	19.13 [485.9]	21.25 [539.8]	23.38 [593.9]	25.5 [647.7]	27.63 [701.8]	29.75 [755.7]	31.88 [809.8]	34.00 [853.6]
apx. Weight alum (KG)	3 [1]	4 [2]	6 [3]	8 [4]	9 [4]	11 [5]	12 [5]	14 [6]	16 [7]	18 [8]	20 [9]	21 [10]	22 [10]	24 [11]	26 [12]	27 [12]
apx. Weight ferrous (KG)	5 [2]	9 [4]	13 [6]	17 [8]	21 [10]	26 [12]	30 [14]	34 [15]	38 [17]	42 [19]	47 [21]	51 [23]	55 [25]	59 [27]	63 [29]	68 [31]

* 1 Length of 01 station with relief cavity is 3 (76.2) . Gauge port not available on 01 station

D03 Series Circuit Manifold



Ordering information

HY* D03 S * 2 * / * / 1X

A Aluminum 7A04 max. working pressure 20.7Mpa
D Ductile Iron 45# max. working pressure 31.5Mpa

Valve Pattern 03 NG 6

Parallel Circuit Standard Flow

No. of Stations
02-08

Valve Spacing
2.13 inch [54.0 mm]

Serial number

Omit	cavities not required
C	One Common cavity: C-10-2 (P in nose)
S	One Sun Cavity: T-10A (P in nose)

Port Threads	P, T	A, B	GA
P NPT(Z)	0.5	0.38	0.25
S SAE	-10	-8	-6
B BSP(G)	0.5	0.38	None
M M	M22x1.5	M18x1.5	None

Code Symbol

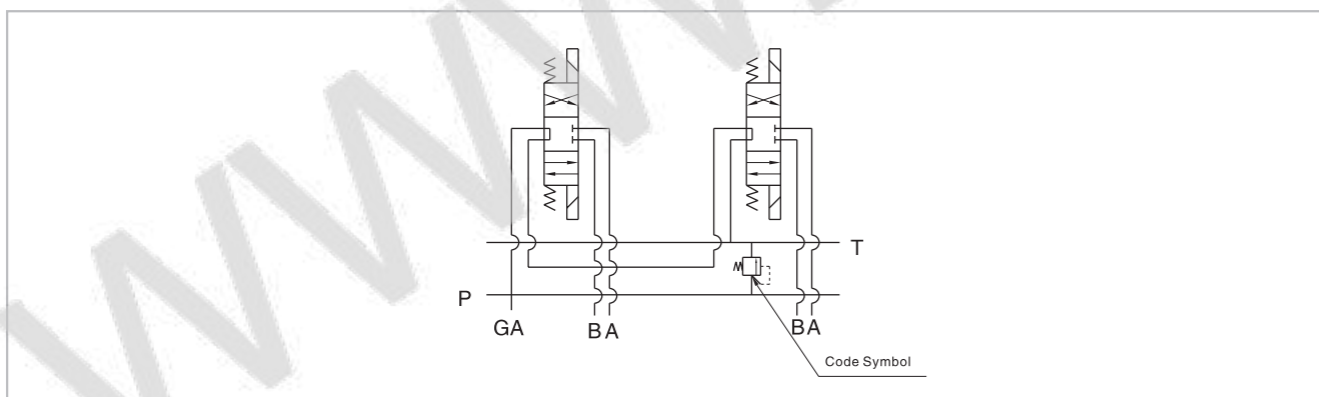

D03 Series Circuit Manifold

External dimensions

Model-View relationship

Model-View relationship

Dimensions: 3.00 [76.2], 1.5 [38.1], 0.31 [7.9], 0.80 [20.3], 2.20 [55.9], 2.38 [60.3], 0.31 [7.9], 3.00 [76.2], 2.38 [60.3], 0.31 [7.9], 1.44 [36.5], 2.13 [54.0] TYP, 0.66 [16.8], 1.06 [27.0], 2.13 [54.0] TYP, 1.50 [38.1], 0.63 [15.9], 2.38 [60.3], 1.00 [25.4], 3.00 [76.2], 0.31 [7.9], 0.31 [7.9], 2.38 [60.3], 1.00 [25.4]

Port code	Valve mounting thread	Manifold mounting thread
P, S	#10-24 UNCx 0.63[16]DP	0.31-18 UNCx 0.44[11.1] DP
B, M	M5 ISO 6Hx 0.63[16]DP	M8 ISO 6Hx 0.44[11.1] DP

No. of stations	02	03	04	05	06	07	08
"A" length inch (mm)	4.25 [108.0]	6.38 [162.1]	8.50 [215.9]	10.63 [270.0]	12.75 [323.9]	14.88 [378.0]	17.00 [431.8]
apx. Weight alum (KG)	4 [2]	6 [3]	8 [4]	9 [4]	11 [5]	12 [5]	14 [6]
apx. Weight ferrous (KG)	9 [4]	13 [6]	17 [8]	23 [10]	26 [12]	-	-

D05 Standard Flow Parallel Manifold



D05 Standard flow parallel manifold

HY* D05 P * 3 * / * / 1X

A Aluminum 7A04 max. working pressure 20.7Mpa
D Ductile Iron 45# max. working pressure 31.5Mpa

Valve Pattern 05 NG 10

Parallel Circuit Standard Flow

Parallel Circuit Standard Flow
01-21

Valve Spacing
3.25 inch [82.6 mm]

Serial number

Omit	cavities not required
C	One Common cavity: C-10-2 (P in nose)
S	One Sun Cavity: T-3A (P in nose)

Port Threads	P, T	A, B	GA
P NPT(Z)	0.75	0.5	0.25
S SAE	-12	-8	-6
B BSP(G)	0.75	0.5	None
M M	M27x2	M18x1.5	None

Code symbol

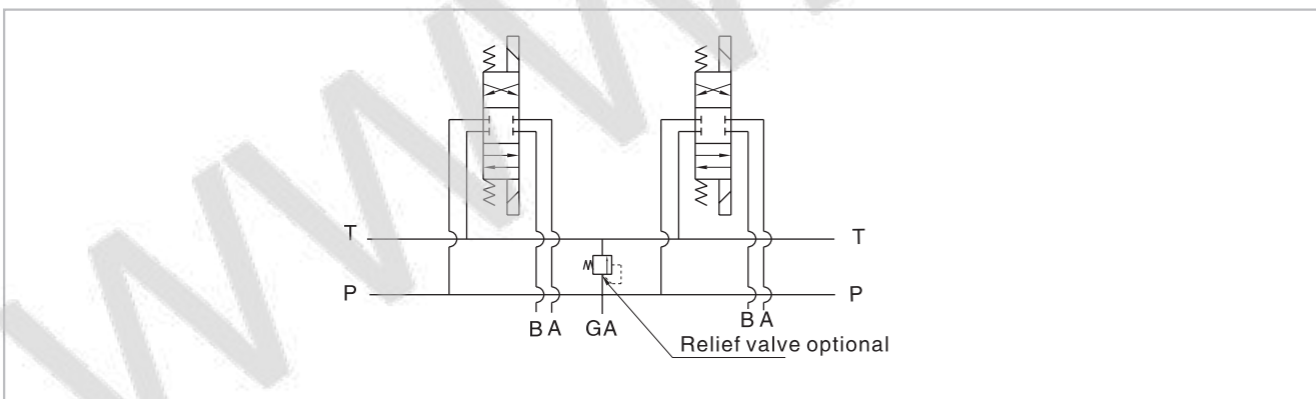

D05 Standard Flow Parallel Manifold

External dimensions

Model-View relationship

Relief valve cavity optional

Port code	Valve mtg	Manifold mtg
P,S	0.25-20 UNCx 0.75[19]DP	0.31-18 UNCx 0.44[11.1]DP
B,M	M6 ISO 6Hx 0.75[19]DP	M8 ISO 6Hx 0.44[11.1]DP

No. of stations	* 01	02	03	04	05	06	07	08	09	10	11
"A" length inch (mm)	3.25 [82.6]	6.50 [165.1]	9.75 [247.7]	13.00 [330.2]	16.25 [412.8]	19.50 [495.3]	22.75 [577.9]	26.00 [660.4]	29.25 [743.0]	32.50 [825.5]	35.75 [908.1]
apx. Weight alum (KG)	4 [2]	8 [4]	11 [5]	14 [7]	17 [8]	21 [10]	24 [11]	27 [12]	30 [14]	34 [15]	37 [17]
apx. Weight ferrous (KG)	9 [4]	17 [8]	26 [12]	34 [15]	43 [20]	51 [23]	60 [27]	68 [31]	77 [35]	85 [39]	94 [43]

No. of stations	12	13	14	15	16	17	18	19	20	21
"A" length inch (mm)	39.00 [990.6]	42.25 [1073.2]	45.50 [1155.7]	48.75 [1238.3]	52.00 [1320.8]	55.25 [1403.4]	58.50 [1485.9]	61.75 [1568.5]	65.00 [1651.0]	68.25 [1733.6]
apx. Weight alum (KG)	41 [19]	44 [20]	47 [21]	51 [23]	55 [25]	58 [26]	61 [28]	64 [29]	67 [30]	71 [32]
apx. Weight ferrous (KG)	102 [46]	--	--	--	--	--	--	--	--	--

*1 Length of 01 station with relief cavity is 3 (76.2) . Gauge port not available on 01 station

D05 Series Circuit Manifold



Ordering information

HY* D05 S * 3 * / * / 1X

A Aluminum 7A04 max. working pressure 20.7Mpa
D Ductile Iron45# max. working pressure 31.5Mpa

Valve Pattern 05 NS 10

Parallel Circuit Standard Flow

No. of Stations
02-04

No. of Stations
3.25 inch [82.6 mm]

Serial number

Omit	Cavities not required
C	One Common cavity: C-10-2 (P in nose)
S	One Sun Cavity: T-3A (P in nose)

Port Threads	P, T	A, B	GA
P NPT(Z)	0.75	0.5	0.25
S SAE	-12	-8	-6
B BSP(G)	0.75	0.5	None
M M	M27x2	M18x1.5	None

Code symbol

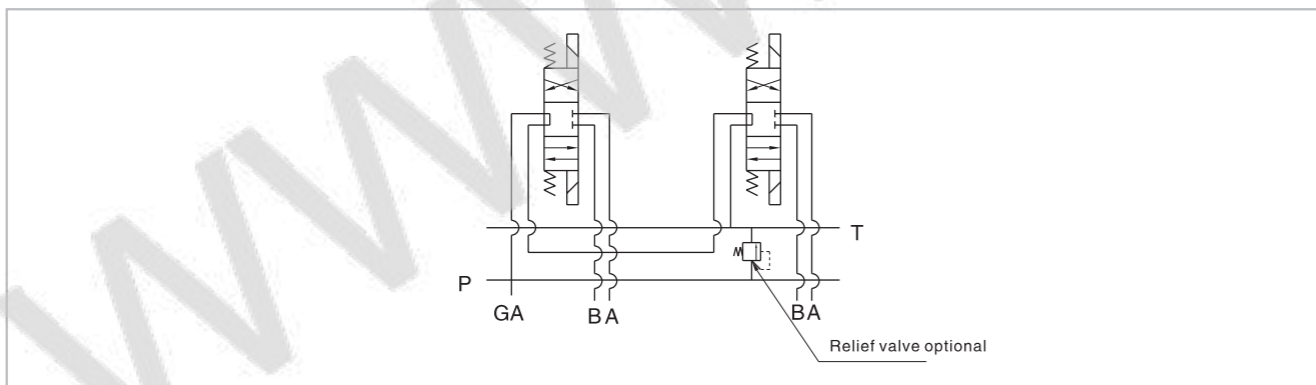

D05 Series Circuit Manifold

D05 Series circuit manifold

Model-View relationship

Relief valve cavity optional

Port code	Valve mtg	Manifold mtg
P,S	0.25-20 UNCx 0.75[19]DP	0.31-18 UNCx 0.44[11.1]DP
B,M	M6 ISO 6Hx 0.75[19]DP	M8 ISO 6Hx 0.44[11.1]DP

No. of stations	02	03	04
No. of stations	6.50 [165.1]	9.75 [247.7]	13.00 [330.2]
apx. Weight alum (KG)	8 [4]	11 [5]	14 [7]
apx. Weight ferrous (KG)	17 [8]	26 [12]	34 [15]

D07 Standard Flow Parallel Circuit Manifold



Ordering information

HY* D07 P * 4 * / * / 1X

A Aluminum 7A04 max. working pressure 20.7Mpa
D Ductile Iron45# max. working pressure 31.5Mpa

Valve Pattern 07 NS 16

Parallel Circuit Standard Flow

No. of Stations
01-08

valve spacing
4 inch [101.6 mm]

Serial number

Omit	cavities not required
C	One Common cavity: C-10-2 (P in nose)
S	One Sun Cavity: T-3A (P in nose)

Port Threads	P, A, B	T	Y	GA
P NPT(Z)	0.75	1	0.38	0.25
S SAE	-12	-16	-6	-6
B BSP(G)	0.75	1	0.38	None
M M	M27x2	M33x2	M14x1.5	None

Code symbol

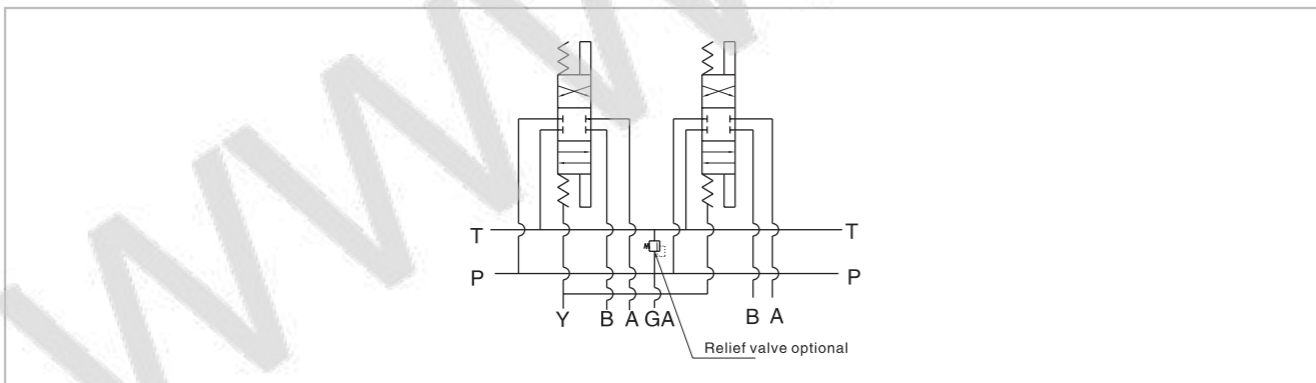

D07 Standard Flow Parallel Circuit Manifold

External dimensions

Model-View relationship

Relief valve cavity optional

Port code	Valve mtg	Manifold mtg
P,S	0.38-16 UNCx1.00[25]DP 0.25-20 UNCx0.75[19]DP	0.38-16 UNCx 0.75[19]DP
B,M	M10 ISO 6Hx1.00[25]DP M6 ISO 6Hx0.75[19]DP	M10 ISO 6Hx 0.75[19]DP

No. of stations	* 01	02	03	04	05	06	07	08
"A" length inch (mm)	4.00 [101.6]	8.00 [203.2]	12.00 [304.8]	16.00 [406.4]	20.00 [508.0]	24.00 [609.6]	28.00 [711.2]	32.00 [812.8]
apx. Weight alum (KG)	6 [3]	14 [6]	22 [10]	30 [14]	38 [17]	46 [21]	52 [24]	60 [27]
apx. Weight ferrous (KG)	24 [11]	46 [21]	69 [31]	90 [41]	114 [52]	135 [61]	158 [72]	180 [82]

* 1 Length of 01 station with relief cavity is 5.5 (139.7) . Gauge port not available on 01 station

D07 Series Circuit Manifold

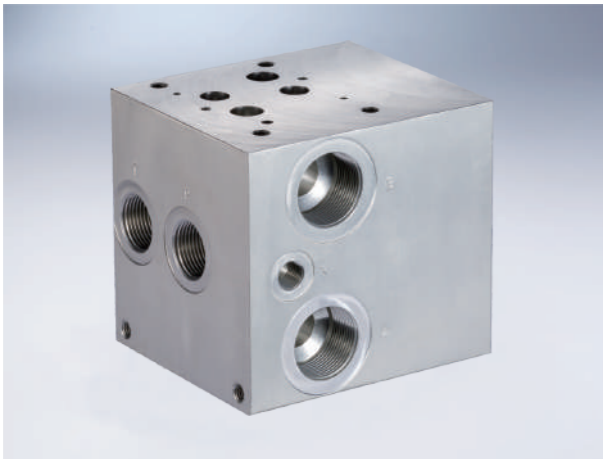

G.6.1

Ordering information

HY* D07 S * 4 * / * / 1X

A Aluminum 7A04 max. working pressure 20.7Mpa
D Ductile Iron45# max. working pressure 31.5Mpa

Valve Pattern 07 NG 16

Series Circuit Standard Flow

No. of Stations
02~04

Valve Spacing
4 inch [101.6 mm]

Serial number

Omit	cavities not required
C	One Common cavity: C-10-2 (P in nose)
S	One Sun Cavity: T-3A (P in nose)

Port Threads	P, A, B	T	Y	GA
P NPT(Z)	0.75	1	0.38	0.25
S SAE	-12	-16	-6	-6
B BSP(G)	0.75	1	0.38	None
M M	M27x2	M33x2	M14x1.5	None

Code symbol

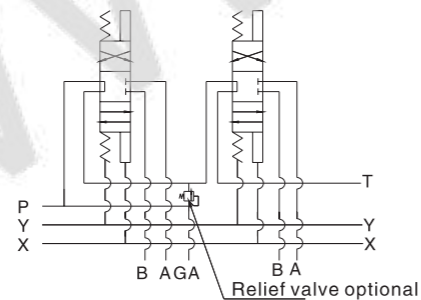

D07 Series Circuit Manifold

External dimensions

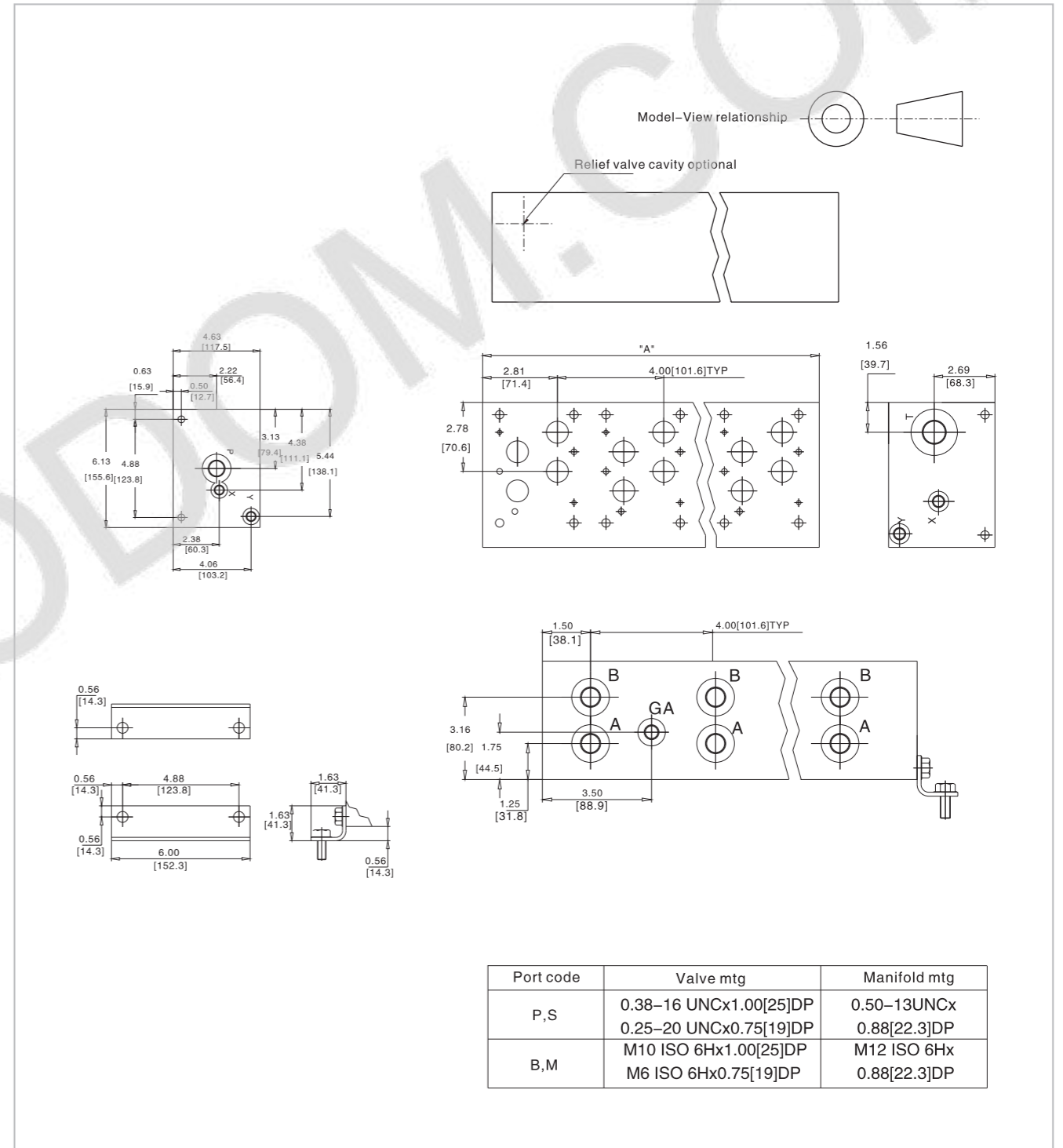

G.6.2

Port code	Valve mtg	Manifold mtg
P,S	0.38-16 UNCx1.00[25]DP	0.50-13UNCx
	0.25-20 UNCx0.75[19]DP	0.88[22.3]DP
B,M	M10 ISO 6Hx1.00[25]DP	M12 ISO 6Hx
	M6 ISO 6Hx0.75[19]DP	0.88[22.3]DP

No. of stations	02	03	04
No. of stations	8.0	12	16.00
	[203.2]	[304.8]	[406.4]
apx. Weight alum (KG)	14	22	30
	[6]	[10]	[14]
apx. Weight ferrous (KG)	46	69	90
	[21]	[31]	[41]

D08 Standard Flow Parallel Manifold



Ordering information

HY* D08 P * 5 * * / * / 1X

Serial number

A Aluminum 7A04 max. working pressure 20.7Mpa
D Ductile Iron 45# max. working pressure 31.5Mpa

Valve Pattern 08 NS 25

Parallel Circuit Standard Flow

No. of Stations 01-07

Valve Spacing 5.25 inch [133.4 mm]

Omit	cavities not required
C	One Common cavity: C-10-2 (P in nose)
S	One Sun Cavity: T-3A (P in nose)

Port Threads	P, A, B	T	Y	GA
P NPT(Z)	1	1.25	0.38	0.25
S SAE	-16	-20	-8	-6
B BSP(G)	1	1.25	0.38	None
M M	M33x2	M42x2	M14x1.5	None

Code symbol

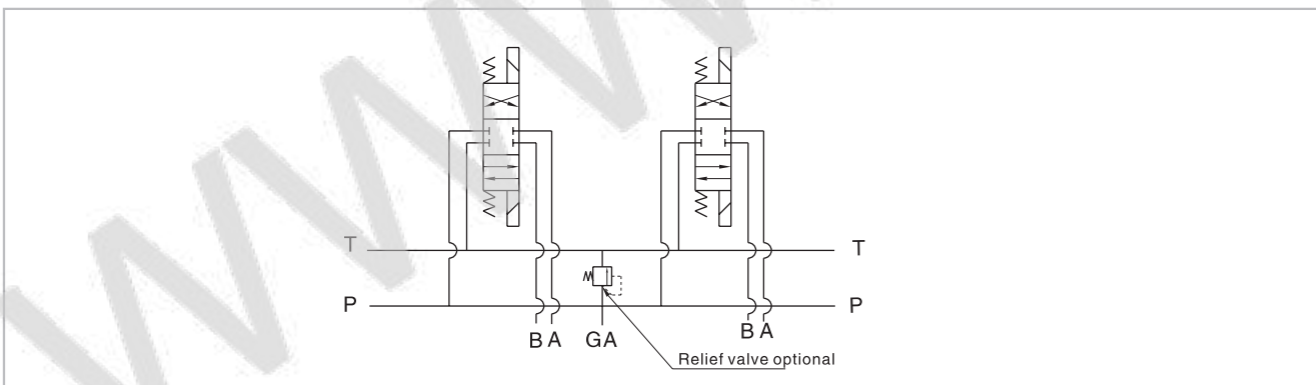

D08 Standard Flow Parallel Manifold

External dimensions

Model-View relationship

Relief valve cavity optional

Port code	Valve mtg	Manifold mtg
P,S	0.50-13 UNCx1.19[30]DP	0.50-13 UNCx 0.88[22.3]DP
B,M	M12 ISO 6Hx1.19[30]DP	M12 ISO 6Hx 0.88[22.3]DP

No. of stations	* 01	02	03	04	05	06	07
"A" length inch (mm)	5.25 [133.4]	10.50 [266.7]	15.75 [400.1]	21.00 [533.4]	26.25 [666.8]	31.50 [800.1]	36.75 [933.5]
apx. Weight alum (KG)	12 [5]	24 [11]	35 [16]	49 [22]	61 [28]	75 [34]	89 [40]
apx. Weight ferrous (KG)	45 [20]	90 [41]	136 [62]	181 [82]	226 [103]	271 [123]	356 [162]

* Gauge port not available on 01 station

D08 Series Circuit Manifold

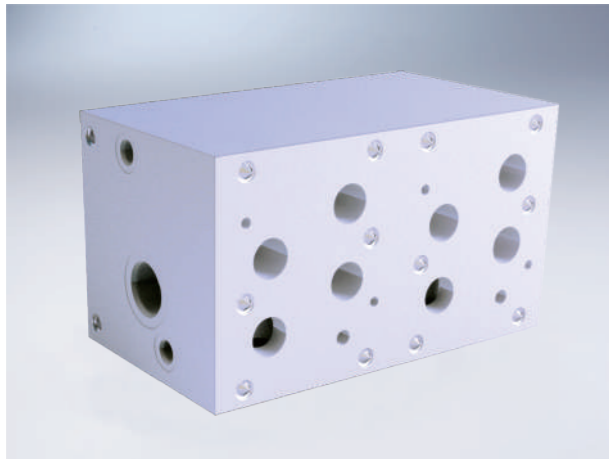

G.8.1

Ordering information

HY* D08 S * * * / * / 1X

A Aluminum 7A04 max. working pressure 20.7Mpa
D Ductile Iron 45# max. working pressure 31.5Mpa

Valve Pattern 08 NS 25

Parallel Circuit Standard Flow

No. of Stations
02-03

Valve Spacing
4 inch [101.6 mm]

Serial number

Omit	cavities not required
C	One Common cavity: C-10-2 (P in nose)
S	One Sun Cavity: T-3A (P in nose)

Port Threads	P, A, B	T	Y	GA
P NPT(Z)	1	1.25	0.38	0.25
S SAE	-16	-20	-8	-6
B BSP(G)	1	1.25	0.38	None
M M	M33x2	M42x2	M14x1.5	None

Code symbol

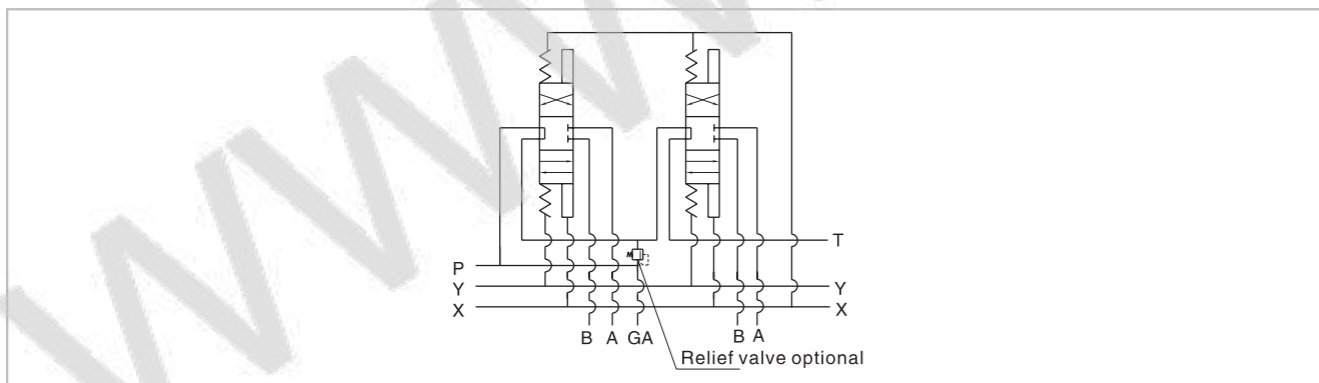

D08 Series Circuit Manifold

External dimensions

Model-View relationship

Relief valve cavity optional

Port code	Valve mounting thread	Manifold mounting thread
P,S	0.50-13 UNCx1.19[30]DP	0.50-13 UNCx 0.88[22.3]DP
B,M	M12 ISO 6Hx1.19[30]DP	M12 ISO 6Hx 0.88[22.3]DP

G.8.2

No. of stations	02	03
"A" length inch (mm)	10.50 [266.7]	15.75 [400.1]
apx. Weight alum (KG)	24 [11]	35 [16]
apx. Weight ferrous (KG)	90 [41]	136 [62]

D03 Subplates

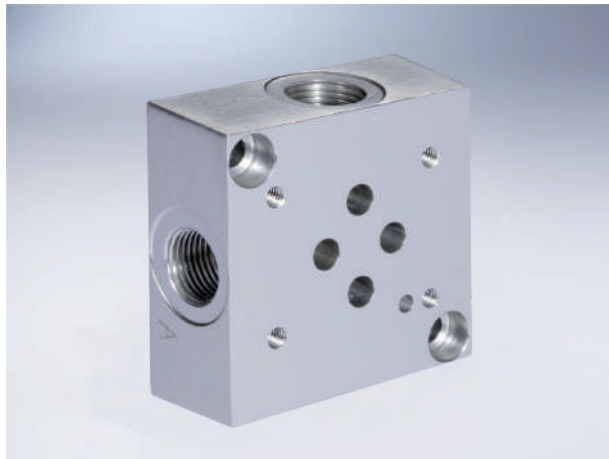

Ordering information

HY* D03 SP * * / 1X

A Aluminum 7A04 max. working pressure 20.7Mpa
D Ductile Iron 45# max. working pressure 31.5Mpa

Valve Pattern 03 NG 6

Product Type: Subplate

Serial number

Port Threads					
4P	1/4"NPT(Z)				
6P	3/8"NPT(Z)	8P	1/2"NPT(Z)	12P	3/4"NPT(Z)
6S	SAE-6	8S	SAE-8	12S	SAE-12
6B	3/8"BSP(G)	8B	1/2"BSP(G)	12B	3/4"BSP(G)
6M	M14X1.5	8M	M18X1.5	12M	M27X2

Port Location
S Side ported
B Back ported

D03 Subplates

External dimensions

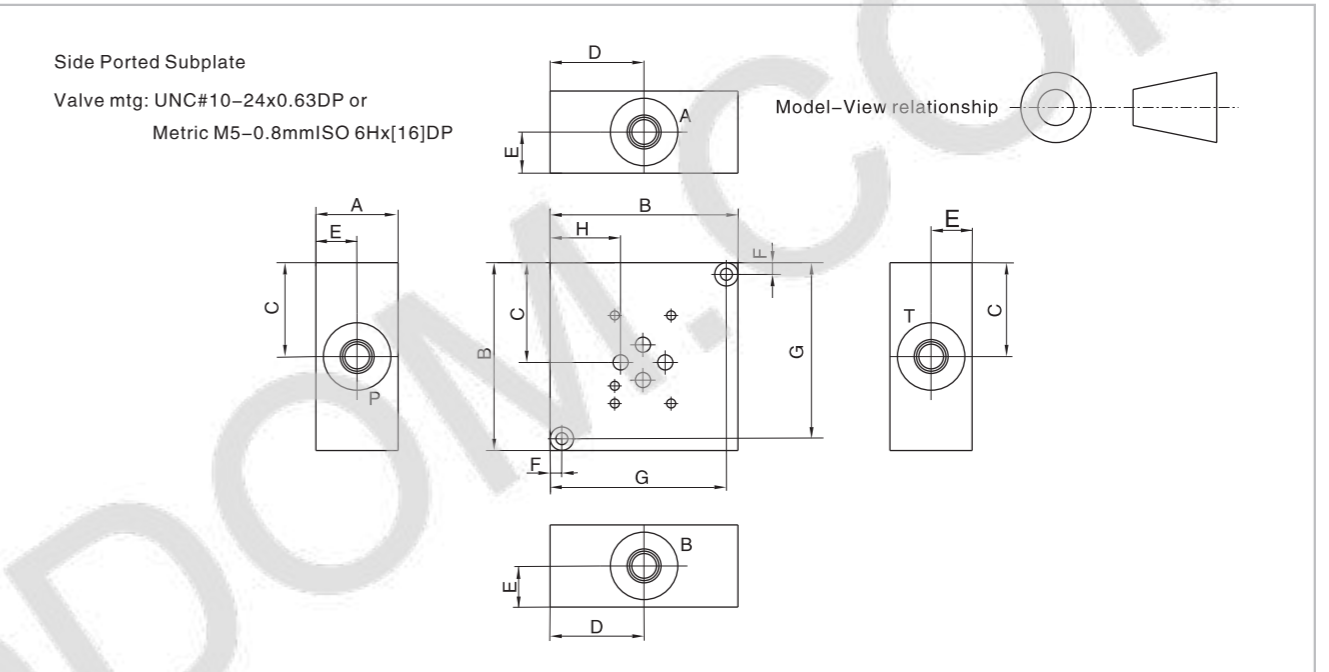

Dimension	A	B	C	D	E	F	G	H
*D03SPS4P *D03SPS6*	1.00 [25.4]	2.50 [63.5]	1.31 [33.3]	1.25 [31.8]	0.50 [12.7]	0.25 [6.4]	2.25 [57.2]	0.88 [22.4]
D03SPS8	1.50 [38.1]	3.50 [88.9]	1.81 [46.0]	1.78 [45.2]	0.75 [19.1]	0.25 [6.4]	3.25 [82.6]	1.38 [34.9]
D03SPS12	1.75 [44.5]	4.00 [101.6]	2.06 [52.4]	2.03 [51.6]	0.88 [22.4]	0.38 [9.5]	3.63 [92.1]	1.63 [41.3]

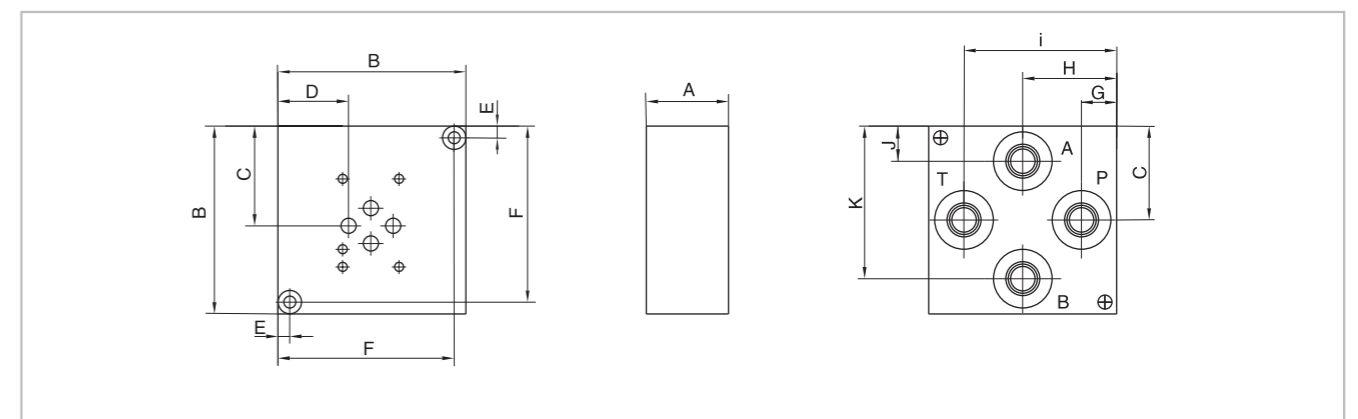

Dimension	A	B	C	D	E	F	G	H	I	J	K
*D03SPB4P	1.00 [25.4]	2.50 [63.5]	1.31 [33.3]	0.88 [22.4]	0.25 [6.4]	2.25 [57.2]	0.66 [16.7]	1.28 [32.5]	1.91 [48.4]	0.75 [19.1]	1.88 [47.6]
*D03SPB6B	1.00 [25.4]	2.50 [63.5]	1.25 [31.8]	0.84 [21.4]	0.25 [6.4]	2.25 [57.2]	0.51 [13.0]	1.25 [31.8]	1.98 [50.4]	0.52 [13.2]	1.97 [50.0]
*D03SPB6[M,P,S,T]	1.00 [25.4]	2.50 [63.5]	1.31 [33.3]	0.88 [22.4]	0.25 [6.4]	2.25 [57.2]	0.59 [15.1]	1.28 [32.5]	1.97 [50.0]	0.69 [17.5]	1.94 [49.2]
D03SPB8	1.50 [38.1]	3.50 [88.9]	1.81 [46.0]	1.38 [34.9]	0.25 [6.4]	3.25 [82.6]	0.69 [17.5]	1.78 [45.2]	2.81 [71.4]	0.75 [19.1]	2.81 [71.4]
D03SPB12	1.50 [38.1]	4.50 [114.3]	2.31 [58.8]	1.88 [47.6]	0.38 [9.5]	4.13 [104.8]	0.94 [23.8]	2.28 [57.9]	3.56 [90.5]	0.94 [23.8]	3.56 [90.5]

D03 Subplates With Relief Cavity

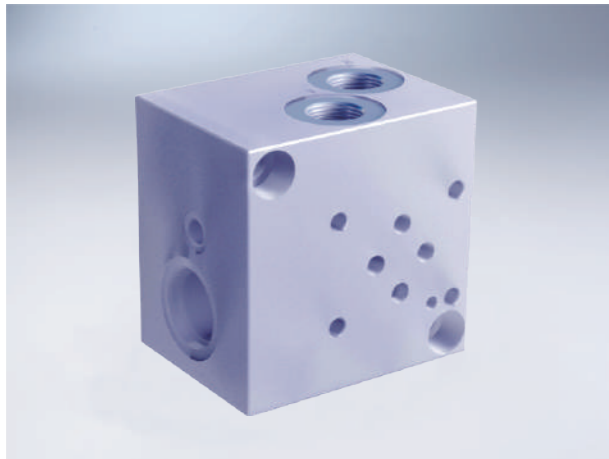

Ordering information

HY* D03 SP * * * / 1X

A Aluminum 7A04 max. working pressure 20.7Mpa
D Ductile Iron 45# max. working pressure 31.5Mpa

Serial number

Valve Pattern 03 NG 6

Port Threads					
6P	3/8"NPT(Z)	8P	1/2"NPT(Z)	12P	3/4"NPT(Z)
6S	SAE-6	8S	SAE-8	12S	SAE-12
6B	3/8"BSP(G)	8B	1/2"BSP(G)	12B	3/4"BSP(G)
6M	M14X1.5	8M	M18X1.5	12M	M27X2

Subplate

Relief Cavity	
C	Common cavity: C-10-2 (P in nose)
S	Sun cavity: T-10A (P in nose)

RV Main Relief P to T

D03 Subplates With Relief Cavity

External dimensions

Dual Ported Subplate with Main Relief Cavity
Valve mtg: UNC#10-24x0.63DP or
Metric M5-0.8mm ISO 6Hx[16]DP

Model-View relationship

Dimension	A	B	C	D	E	F	G	H	I
*D03SPRV*6*	2.25 [57.2]	3.00 [76.2]	0.31 [7.9]	2.69 [68.3]	0.97 [24.6]	2.00 [50.8]	0.69 [17.5]	1.66 [42.1]	1.66 [42.1]
*D03SPRV*8*	3.00 [76.2]	3.50 [88.9]	0.38 [9.5]	3.12 [79.4]	1.34 [34.1]	2.19 [55.6]	0.81 [20.6]	1.50 [38.1]	2.00 [50.8]
*D03SPRV*12*	3.00 [76.2]	4.00 [101.6]	0.38 [9.5]	3.63 [92.1]	1.59 [40.5]	2.38 [60.3]	0.84 [21.4]	1.50 [38.1]	2.13 [54.0]

Dimension	J	K	L	M	N	O	P	Q	R
*D03SPRV*6*	0.88 [22.4]	0.84 [21.3]	0.88 [22.4]	1.63 [41.3]	1.53 [38.9]	2.37 [60.2]	0.97 [24.6]	1.69 [42.9]	0.69 [17.5]
*D03SPRV*8*	1.00 [25.4]	1.09 [22.8]	0.84 [21.4]	1.91 [48.4]	1.72 [43.6]	2.53 [64.3]	1.09 [22.8]	2.25 [57.2]	0.81 [20.6]
*D03SPRV*12*	1.00 [25.4]	1.34 [34.1]	0.84 [21.4]	1.91 [48.4]	1.91 [48.4]	3.19 [81.0]	1.34 [34.1]	2.50 [63.5]	0.88 [22.2]

D05 Subplates



Ordering information

HY* D05 SP * * / 1X

A Aluminum 7A04 max. working pressure 20.7Mpa
D Ductile Iron 45# max. working pressure 31.5Mpa

Serial number

Valve Pattern 05 NG 10

Subplate

Port Threads	
6P	3/8"NPT(Z)
8P	1/2"NPT(Z)
8S	SAE-8
8B	1/2"BSP(G)
8M	M18X1.5

Port Location
S Side ported
B Back Ported

D05 Subplates

External dimensions

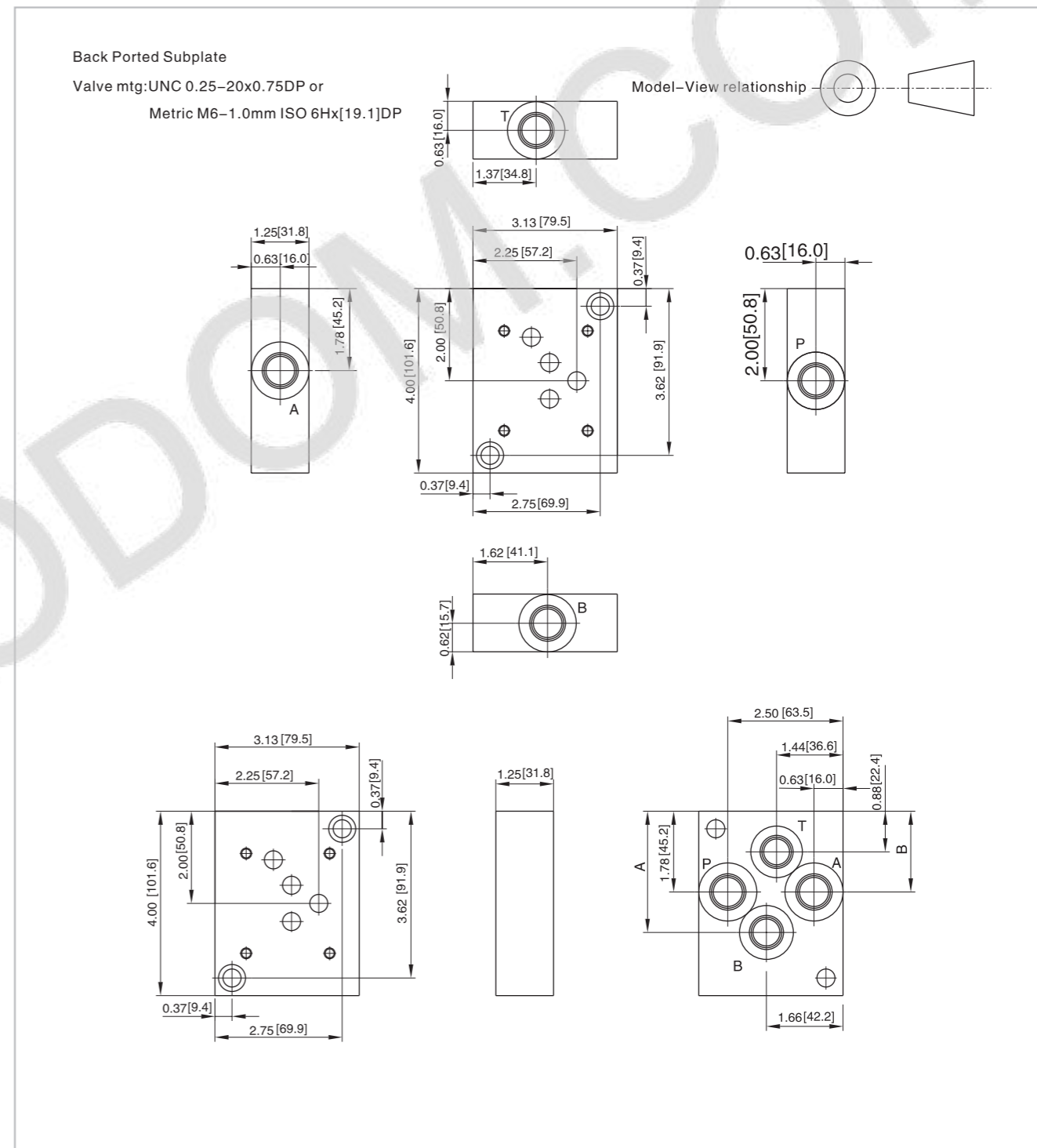

Dimension	A	B
*D05SPB6P	2.63 [66.8]	1.75 [44.5]
*D05SPB8B	2.94 [74.6]	2.00 [50.8]
*D05SPB8[M,P,S,T]	2.63 [66.8]	1.75 [44.5]

D05 Subplates With Relief Cavity

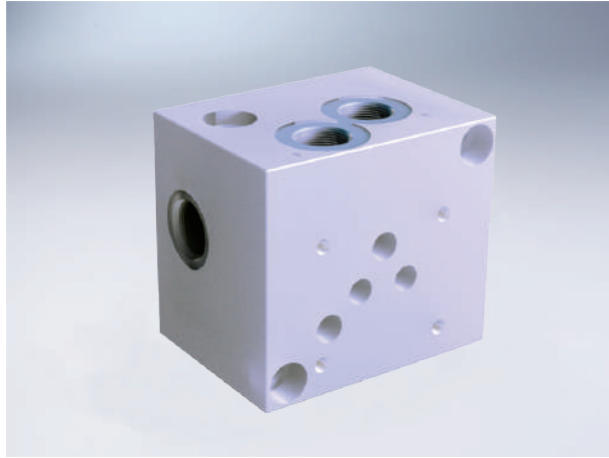

Ordering information

HY* D05 SP * * * / 1X

Serial number

A Aluminum 7A04 max. working pressure 20.7Mpa
D Ductile Iron 45# max. working pressure 31.5Mpa

Valve Pattern 05 NG 10

Subplate

RV Main Relief P to T

Port Threads	
8P	1/2"NPT(Z)
8S	SAE-8
8B	1/2"BSP(G)
8M	M18X1.5

Relief Cavity	
C	Common cavity: C-10-2 (P in nose)
S	Sun cavity: T-10A (P in nose)

D05 Subplates With Relief Cavity

External dimensions

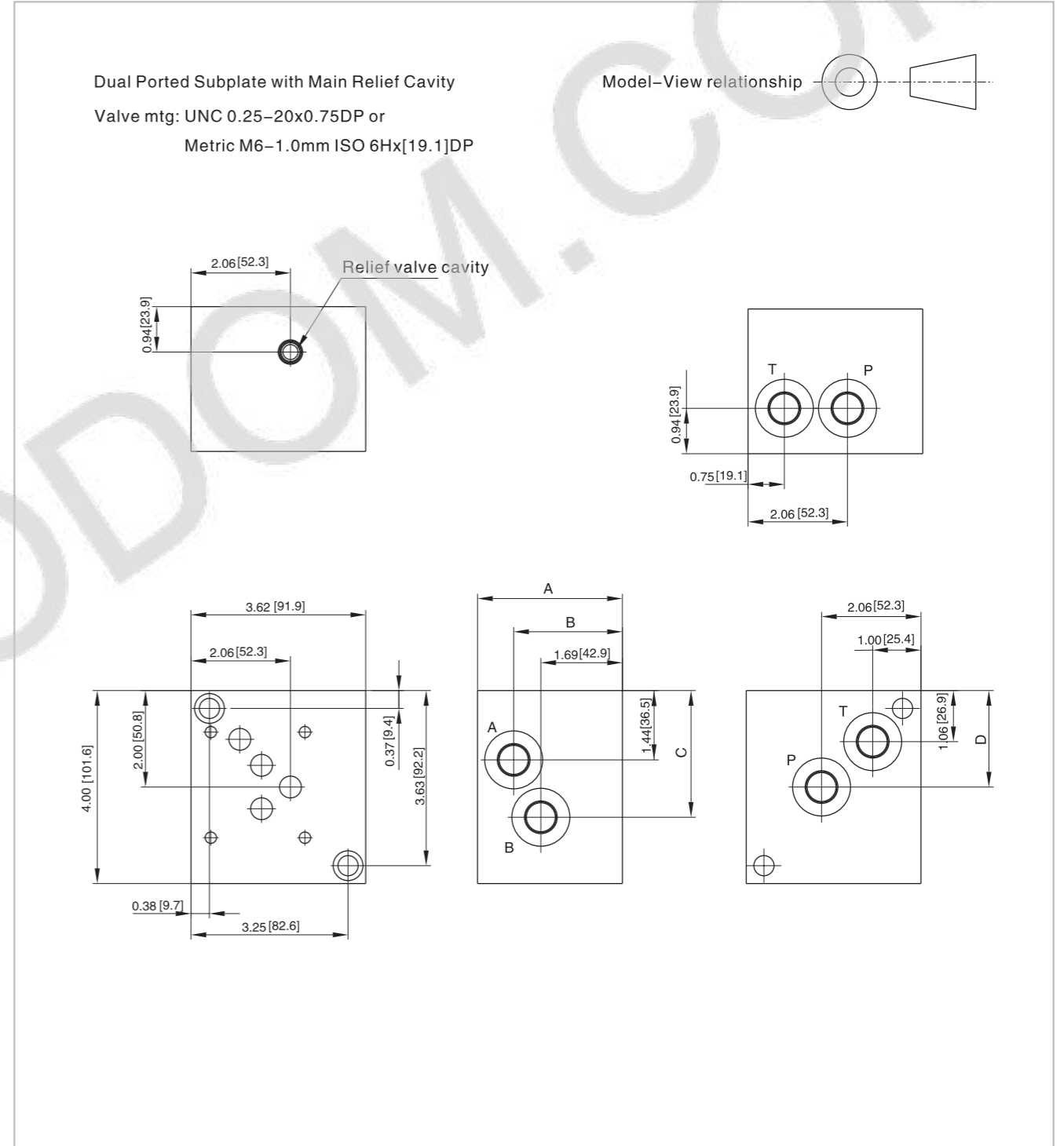

Dimension	A	B	C	D
*D05SPRVC8B	3.00 [76.2]	2.25 [57.2]	2.63 [66.7]	2.00 [50.8]
*D05SPRVS8B	3.00 [76.2]	2.25 [57.2]	2.63 [66.7]	2.06 [52.4]
*D05SPRV*8[M,P,S,T]	2.50 [63.5]	1.69 [42.9]	2.56 [65.1]	2.00 [50.8]

D07 Subplates



Ordering information

HY* D07 SP * * / 1X

A Aluminum 7A04 max. working pressure 20.7Mpa
D Ductile Iron 45# max. working pressure 31.5Mpa

Valve Pattern 07 NG 16

Subplate

Port Location
SO Side ported
B Back ported

Serial number

P, A, B, T Port Threads				X & Y port size	
12P	3/4"NPT(Z)	16P	1"NPT(Z)	1/4"NPT(Z)	
12S	SAE-12	16S	SAE-16	SAE-6	
12B	3/4"BSP(G)	16B	1"BSP(G)	1/4"BSP(G)	
12M	M27X2	16M	M33X2	M14X1.5	

External dimensions

Dimension	A	B	C	D	E	F	G	H	I
D07SPSO12	1.75 [44.5]	3.75 [95.3]	4.75 [120.7]	2.34 [59.4]	0.38 [9.5]	4.38 [111.3]	1.88 [47.8]	2.69 [68.3]	0.81 [20.6]
D07SPST12	1.75 [44.5]	3.75 [95.3]	4.75 [120.7]	2.34 [59.4]	0.38 [9.5]	4.38 [111.3]	1.88 [47.8]	2.69 [68.3]	0.81 [20.6]
D07SPSO16	3.00 [76.2]	5.00 [127.0]	5.50 [139.7]	2.97 [75.4]	0.50 [12.7]	5.00 [127.0]	2.50 [63.5]	3.31 [84.2]	1.19 [30.2]
*D07SPB12B	1.50 [38.1]	4.00 [101.6]	4.75 [120.7]	2.34 [59.4]	0.38 [9.5]	4.37 [111.0]	2.00 [50.8]	2.81 [71.4]	1.09 [27.7]
*D07SPB12[M,P,S,T]	1.50 [38.1]	4.00 [101.6]	4.75 [120.7]	2.34 [59.4]	0.38 [9.5]	4.37 [111.0]	2.00 [50.8]	2.81 [71.4]	1.09 [27.7]
D07SPB16	2.75 [69.9]	5.00 [127.0]	6.00 [152.4]	2.97 [75.4]	0.50 [12.7]	5.50 [139.7]	2.50 [63.5]	3.31 [84.2]	1.25 [31.8]

D07 Subplates

External dimensions

Side Ported Subplate
Valve mtg: UNC 0.25-20x0.75DP and UNC 0.38-16x1.00DP or
Metric M6-1.0mm ISO 6Hx[19.1]DP and M10-1.5mm ISO 6Hx[25.4]DP

Model-View relationship

Back Ported Subplate
Valve mtg: UNC 0.25-20x0.75DP and UNC 0.38-16x1.00DP or
Metric M6-1.0mm ISO 6Hx[19.1]DP and M10-1.5mm ISO 6Hx[25.4]DP

Dimension	J	K	L	M	N	O	P	Q	R
D07SPSO12	1.50 [38.1]	3.13 [79.5]	1.19 [30.2]	2.78 [70.6]	1.25 [31.8]	1.12 [28.4]	2.62 [66.5]	---	---
D07SPST12	1.50 [38.1]	3.13 [79.5]	---	2.78 [70.6]	1.25 [31.8]	1.12 [28.4]	2.62 [66.5]	1.09 [27.7]	2.69 [68.3]
D07SPSO16	1.81 [46.0]	4.13 [104.8]	1.19 [30.2]	3.50 [88.9]	2.38 [60.3]	1.75 [44.5]	3.25 [82.6]	---	---
*D07SPB12B	2.75 [69.9]	4.00 [101.6]	1.19 [30.2]	2.81 [71.4]	4.09 [103.9]	1.13 [28.7]	2.94 [74.7]	1.13 [28.7]	2.94 [74.7]
*D07SPB12[M,P,S,T]	2.81 [71.4]	4.00 [101.6]	1.25 [31.8]	2.91 [73.9]	4.09 [103.9]	1.13 [28.7]	2.94 [74.7]	1.13 [28.7]	2.94 [74.7]
D07SPB16	3.50 [88.9]	5.31 [134.9]	1.38 [34.9]	3.63 [92.1]	5.31 [134.9]	1.38 [34.9]	3.63 [92.1]	1.63 [41.3]	3.44 [87.3]

D07 Subplates With Relief Cavity

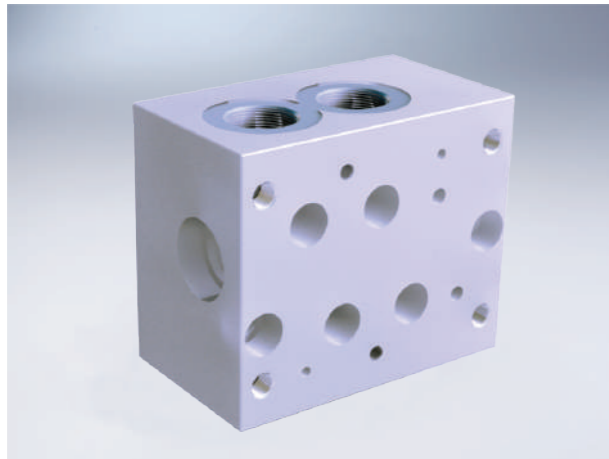

Ordering information

HY* D07 SP * * * / 1X

A Aluminum 7A04 max. working pressure 20.7Mpa
D Ductile Iron 45# max. working pressure 31.5Mpa

Valve Pattern 07 NG 16

Subplate

RV Main Relief P to T

Serial number

P, A, B, T Port Threads				X & Y port size	
12P	3/4"NPT(Z)	16P	1"NPT(Z)	1/4"NPT(Z)	
12S	SAE-12	16S	SAE-16	SAE-6	
12B	3/4"BSP(G)	16B	1"BSP(G)	1/4"BSP(G)	
12M	M27X2	16M	M33X2	M14X1.5	

Relief Cavity	
C	C-10-2 w/12* ports C-16-2 w/16* ports
S	T-3A w/12* ports T-16A w/16* ports

D07 Subplates With Relief Cavity

External dimensions

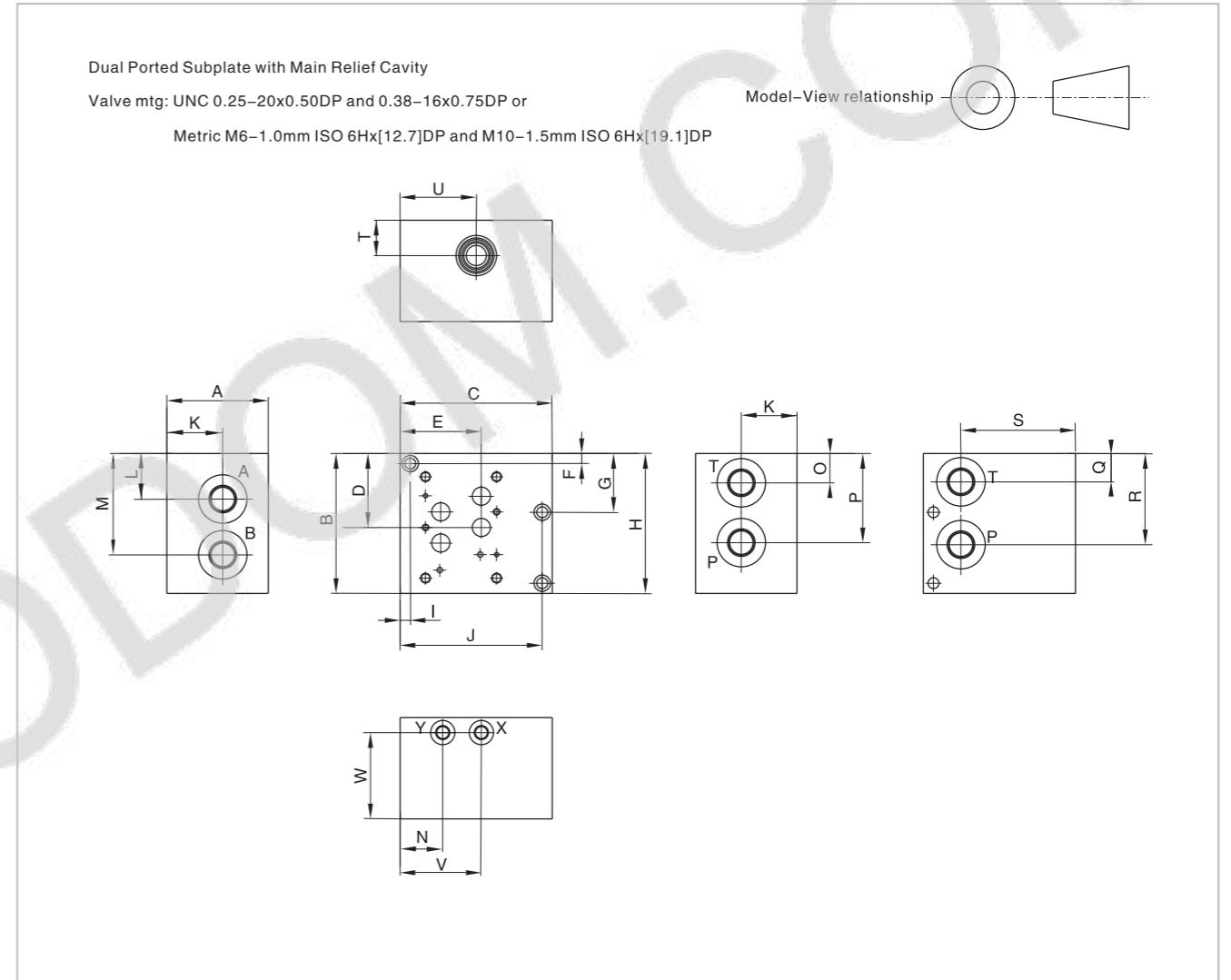

Dimension	A	B	C	D	E	F	G	H	I	J	K	L
D07SPRVC12	2.75	4.75	4.00	2.34	2.81	0.38	---	4.37	1.38	2.00	1.50	1.50
	[69.9]	[120.7]	[101.6]	[59.4]	[71.4]	[9.5]	---	[111.0]	[35.1]	[50.8]	[38.1]	[38.1]
D07SPRVS12	2.50	4.75	4.00	2.34	2.81	0.38	---	4.37	1.38	2.00	1.25	1.50
	[63.5]	[120.7]	[101.6]	[59.4]	[71.4]	[9.5]	---	[111.0]	[35.1]	[50.8]	[31.8]	[38.1]
D07SPRVC16	4.00	5.50	6.00	2.97	3.31	0.38	2.25	5.13	0.38	5.63	2.19	1.81
	[101.6]	[139.7]	[152.4]	[75.4]	[84.2]	[9.5]	[57.2]	[130.2]	[9.5]	[142.9]	[55.6]	[46.0]
D07SPRVS16	4.00	5.50	6.00	2.97	3.31	0.38	2.25	5.13	0.38	5.63	2.19	1.81
	[101.6]	[139.7]	[152.4]	[75.4]	[84.2]	[9.5]	[57.2]	[130.2]	[9.5]	[142.9]	[55.6]	[46.0]

Dimension	M	N	O	P	Q	R	S	T	U	V	W
D07SPRVC12	3.12	1.19	1.19	2.78	1.13	2.75	2.81	1.75	2.22	2.81	2.25
	[79.2]	[30.2]	[30.2]	[70.6]	[28.6]	[69.9]	[71.4]	[44.5]	[56.4]	[71.4]	[57.2]
D07SPRVS12	3.12	1.19	1.19	2.78	1.13	2.75	2.81	1.25	2.31	2.81	2.00
	[79.2]	[30.2]	[30.2]	[70.6]	[28.6]	[69.9]	[71.4]	[31.8]	[28.7]	[71.4]	[50.8]
D07SPRVC16	4.13	1.75	1.00	3.50	1.13	3.69	4.50	1.50	3.00	3.25	3.38
	[104.8]	[44.5]	[25.4]	[88.9]	[28.6]	[93.7]	[114.3]	[38.1]	[76.2]	[82.6]	[85.7]
D07SPRVS16	4.13	1.75	1.13	3.50	1.13	3.69	4.50	1.50	3.00	3.25	3.38
	[104.8]	[44.5]	[28.6]	[88.9]	[28.6]	[93.7]	[114.3]	[38.1]	[76.2]	[82.6]	[85.7]

D08 Subplates



Model description

HY* D08 SP * * / 1X

A Aluminum 7A04 max. working pressure 20.7Mpa
D Ductile Iron 45# max. working pressure 31.5Mpa

Valve Pattern 08 NS 25

Subplate

Port Location
SO Side ported
B Back ported

Serial number

P, A, B, T Port Threads					X & Y port size	
12P	3/4"NPT(Z)				1/4"NPT(Z)	
16P	1"NPT(Z)	20P	1-1/4"NPT(Z)		1/4"NPT(Z)	
16S	SAE-16	20S	SAE-20		SAE-6	
16B	1"BSP(G)	20B	1-1/4"BSP(G)		1/4"BSP(G)	
16M	M33X2	20M	M42X2		M14X1.5	

External dimensions

Dimension	A	B	C	D	E	F	G	H	I	J	K
*D08SPSO12P, *D08SPSO16*	2.00 [50.8]	6.13 [155.7]	4.50 [114.3]	1.19 [30.2]	2.53 [64.3]	4.53 [115.1]	1.00 [25.4]	1.00 [25.4]	0.50 [12.7]	3.53 [89.7]	5.62 [142.7]
*D08SPST12P, *D08SPST16*	2.00 [50.8]	6.13 [155.7]	4.50 [114.3]	1.19 [30.2]	2.53 [64.3]	4.53 [115.1]	1.00 [25.4]	1.00 [25.4]	0.50 [12.7]	3.53 [89.7]	5.62 [142.7]
D08SPSO20	3.00 [76.2]	6.50 [165.1]	5.00 [127.0]	1.31 [33.3]	2.33 [59.2]	4.77 [121.2]	1.13 [28.6]	2.38 [60.3]	0.50 [12.7]	3.72 [94.5]	6.00 [152.4]
*D08SPSO20M	4.00 [101.6]	6.50 [165.1]	5.00 [127.0]	1.38 [34.9]	2.33 [59.2]	4.77 [121.2]	1.63 [41.3]	3.13 [79.4]	0.50 [12.7]	3.72 [94.5]	6.00 [152.4]
*D08SPB16B	1.50 [38.1]	6.13 [155.7]	4.63 [117.6]	0.50 [12.7]	3.53 [89.7]	5.62 [142.7]	2.31 [58.7]	3.44 [87.4]	---	1.19 [30.2]	1.19 [30.2]
*D08SPB12P, *D08SPB16[M,P,S,T]	1.50 [38.1]	6.13 [155.7]	4.63 [117.6]	0.50 [12.7]	3.53 [89.7]	5.62 [142.7]	2.31 [58.7]	3.44 [87.4]	---	1.19 [30.2]	1.19 [30.2]
D08SPB20	2.00 [50.8]	7.63 [193.8]	5.00 [127.0]	0.38 [9.7]	4.28 [108.7]	7.25 [184.2]	0.38 [9.7]	3.63 [92.2]	4.63 [117.6]	1.44 [36.6]	1.75 [44.5]

Dimension

External dimensions

Side Ported Subplate
Valve mtg: UNC 0.50-13x1.19DP or
Metric M12-1.75mm ISO 6Hx[30.2]DP

Model-View relationship

Dimension	L	M	N	O	P	Q	R	S	T	U
*D08SPSO12P, *D08SPSO16*	2.25 [57.2]	3.38 [85.9]	1.56 [39.7]	3.59 [91.2]	4.94 [125.5]	---	---	---	---	---
*D08SPST12P, *D08SPST16*	2.25 [57.2]	3.38 [85.9]	---	3.59 [91.2]	4.94 [125.5]	1.66 [42.1]	3.38 [85.9]	---	---	---
D08SPSO20	2.50 [63.5]	3.63 [92.2]	1.73 [43.9]	4.17 [105.9]	5.19 [131.8]	---	---	---	---	---
*D08SPSO20M	2.50 [63.5]	3.63 [92.2]	1.73 [43.9]	4.17 [105.9]	5.13 [130.2]	---	---	---	---	---
*D08SPB16B	3.44 [87.4]	3.44 [87.4]	1.53 [38.9]	5.16 [131.0]	0.97 [24.6]	2.47 [62.7]	3.66 [92.9]	4.59 [116.7]	1.25 [31.8]	3.38 [85.9]
*D08SPB12P, *D08SPB16[M,P,S,T]	3.44 [87.4]	3.44 [87.4]	1.66 [42.2]	4.94 [125.5]	1.19 [30.2]	2.59 [65.8]	3.53 [89.7]	4.47 [113.5]	1.25 [31.8]	3.38 [85.9]
D08SPB20	3.25 [82.6]	3.56 [90.4]	1.84 [46.7]	6.00 [152.4]	1.63 [41.3]	3.31 [84.1]	4.31 [109.5]	5.78 [146.8]	1.44 [36.6]	3.56 [90.4]

D08 Subplates With Relief Cavity

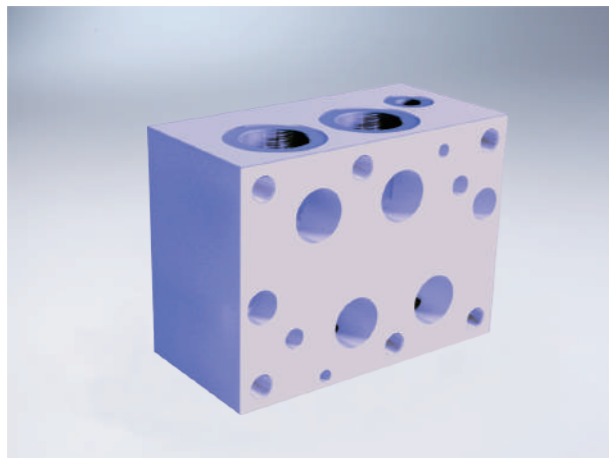

G.16.1

Model description

HY* D08 SP * * * / 1X

A Aluminum 7A04 max. working pressure 20.7Mpa
D Ductile Iron 5# max. working pressure 31.5Mpa

Serial number

Valve Pattern 08 NS 25

	P,A,B,T Port Threads			X & Y port size
16P	1"NPT(Z)	20P	1-1/4"NPT(Z)	1/4"NPT(Z)
16S	SAE-16	20S	SAE-20	SAE-6
16B	1"BSP(G)	20B	1-1/4"BSP(G)	1/4"BSP(G)
16M	M33X2	20M	M42X2	M14X1.5

Subplate

Relief Cavity	
C	C-10-2 w/16* ports C-16-2 w/20* ports
S	T-3A w/16* ports T-16A w/20* ports

RV Main Relief P to T

G.16.1

D08 Subplates With Relief Cavity

External dimensions

Dual Ported Subplate with Main Relief Cavity
Valve mtg: UNC 0.50-13x1.19DP or
Metric M12-1.75mm ISO 6Hx[30.2]DP

Model-View relationship

Relief valve cavity

Thru mounting holes on 16* ports only
Bottom mounting holes, size 20 ports only
UNC 0.5-13x1.19DP for 20P and 20S
ISO 6H M12-1.75mmx[30]DP on 20B, 20M

G.16.2

Dimension	A	B	C	D	E	F	G	H	I	J	K	L	M	N
D08SPRVC16	3.00 [76.2]	6.00 [152.4]	4.50 [114.3]	0.91 [23.1]	2.41 [61.2]	4.53 [115.1]	1.87 [47.5]	1.87 [47.5]	1.25 [31.8]	3.47 [88.1]	3.38 [85.9]	1.68 [42.7]	2.56 [65.0]	1.47 [37.3]
D08SPRVS16	3.00 [76.2]	6.00 [152.4]	4.50 [114.3]	0.91 [23.1]	2.41 [61.2]	4.53 [115.1]	1.87 [47.5]	1.87 [47.5]	1.25 [31.8]	3.47 [88.1]	3.38 [85.9]	1.68 [42.7]	2.56 [65.0]	1.47 [37.3]
D08SPRV20	4.88 [124.0]	6.00 [152.4]	4.88 [124.0]	1.19 [30.2]	2.41 [61.2]	4.69 [119.1]	2.75 [69.9]	2.75 [69.9]	4.00 [101.6]	3.47 [88.1]	3.56 [90.4]	--	--	1.59 [40.4]
*D08SPRV*20M	4.88 [124.0]	6.00 [152.4]	4.88 [124.0]	1.19 [30.2]	2.41 [61.2]	4.69 [119.1]	2.00 [50.8]	2.75 [69.9]	4.00 [101.6]	3.47 [88.1]	3.56 [90.4]	--	--	1.59 [40.4]

Dimension	O	P	Q	R	S	T	U	V	W	X	Y	Z	AA
D08SPRVC16	3.59 [91.2]	5.09 [129.3]	1.87 [47.5]	1.87 [47.5]	--	1.25 [31.8]	2.47 [62.7]	--	3.50 [88.9]	--	0.44 [11.2]	5.56 [141.2]	3.59 [91.2]
D08SPRVS16	3.59 [91.2]	5.09 [129.3]	1.87 [47.5]	1.87 [47.5]	--	1.87 [47.5]	2.81 [71.4]	--	3.50 [88.9]	--	0.44 [11.2]	5.56 [141.2]	3.59 [91.2]
D08SPRV20	3.60 [91.4]	4.88 [124.0]	2.00 [50.8]	3.00 [76.2]	5.56 [141.2]	3.50 [88.9]	2.63 [66.7]	0.44 [11.2]	3.13 [79.5]	4.44 [112.8]	--	--	3.84 [97.6]
*D08SPRV*20M	4.00 [101.6]	4.88 [124.0]	2.00 [50.8]	2.38 [60.3]	5.56 [141.2]	3.50 [88.9]	2.63 [66.7]	0.44 [11.2]	3.13 [79.5]	4.44 [112.8]	--	--	4.00 [101.6]

G.16.2